

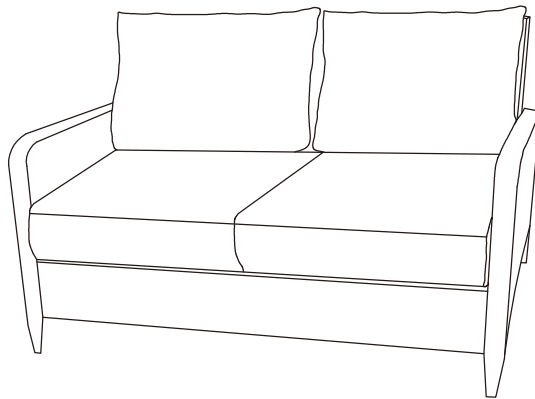

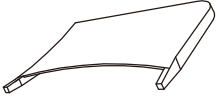

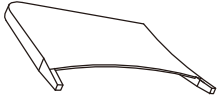







Outdoor Wicker Loveseat
CO7117

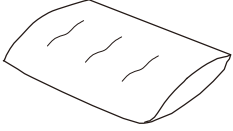

PART LIST

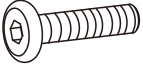
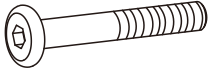
<p>A</p> 	<p>B</p> 	<p>C</p> 	<p>D</p> 	<p>E</p> 
<p>Left Arm Panel 1 PC</p>	<p>Right Arm Panel 1 PC</p>	<p>Back Panel 1 PC</p>	<p>Seat Panel 1 PC</p>	<p>Seat Cushion Cover * 2 PCS</p>
<p>F</p> 	<p>M</p> 	<p>N</p> 	<p>*Please note cushion covers will ship separately.</p>	
<p>Seat Cushion Core 2 PCS</p>	<p>Back Cushion Cover * 2 PCS</p>	<p>Back Cushion Core 2 PCS</p>		

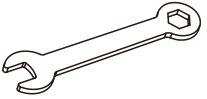
HARDWARE LIST

<p>G</p>  <p>M6*40mm</p>	<p>H</p>  <p>M6*50mm</p>	<p>I</p>  <p>M6mm</p>	<p>J</p>  <p>M6mm</p>	<p>K</p>  <p>M6mm</p>
<p>Short Bolt 7 PCS (Extra 2)</p>	<p>Long Bolt 4 PCS (Extra 1)</p>	<p>Hex Nut 4 PCS (Extra 1)</p>	<p>Flat Washer 15 PCS (Extra 3)</p>	<p>Wrench 1 PC</p>
<p>L</p>  <p>M6mm</p>				
<p>Allen Wrench 1 PC</p>				

Step 5. Attach right arm panel (part B) to assembled unit (parts C & D) using short bolts (part G), long bolts (part H), flat washers (part J), hex nuts (part I), wrench (part K) and allen wrench (part L).

NOTE: Please fully tighten all bolts at this time.

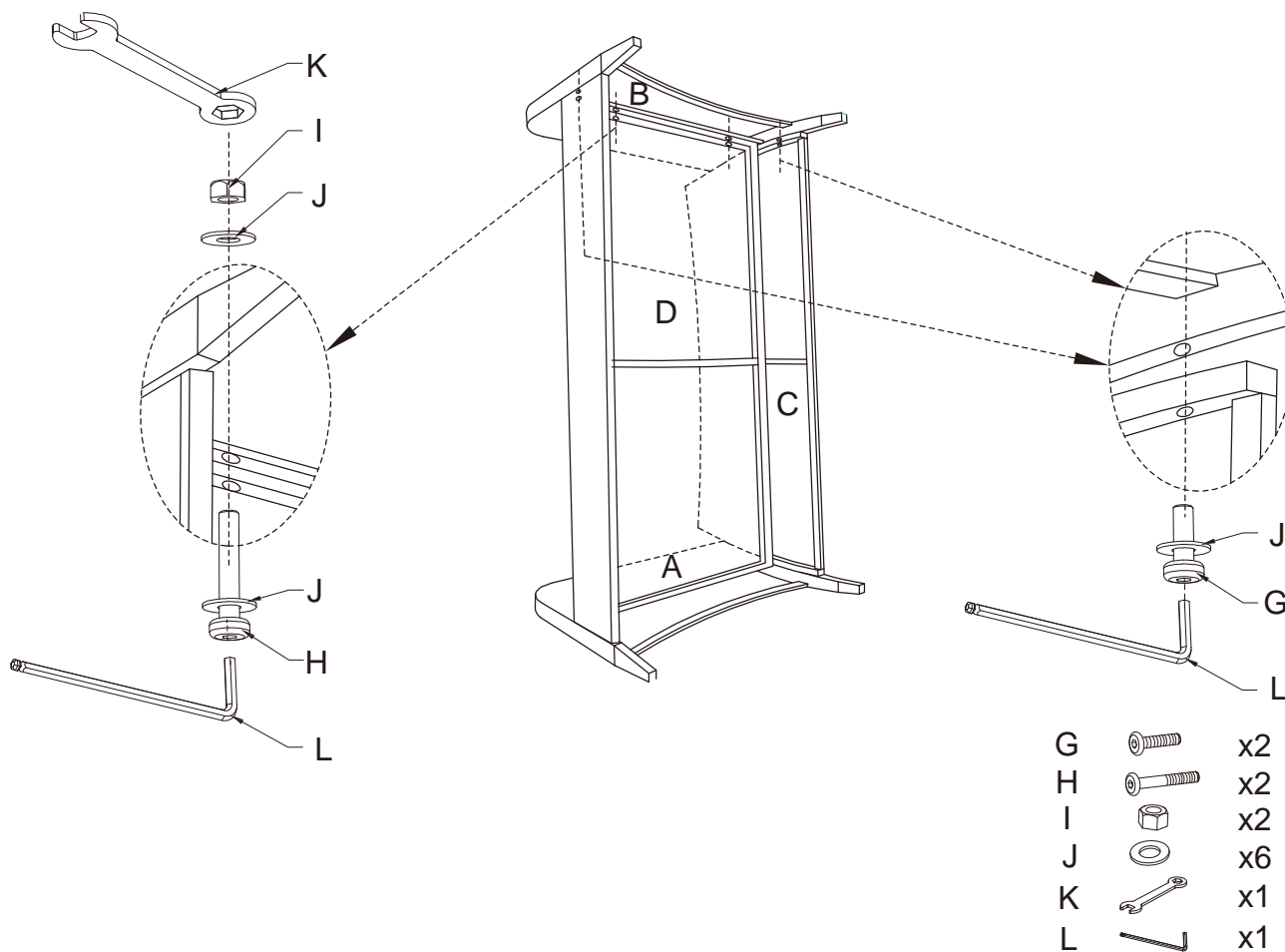

Step 6. Insert seat cushion cores (part F) into seat cushion covers (part E).
Insert back cushion cores (part N) into back cushion covers (part M).

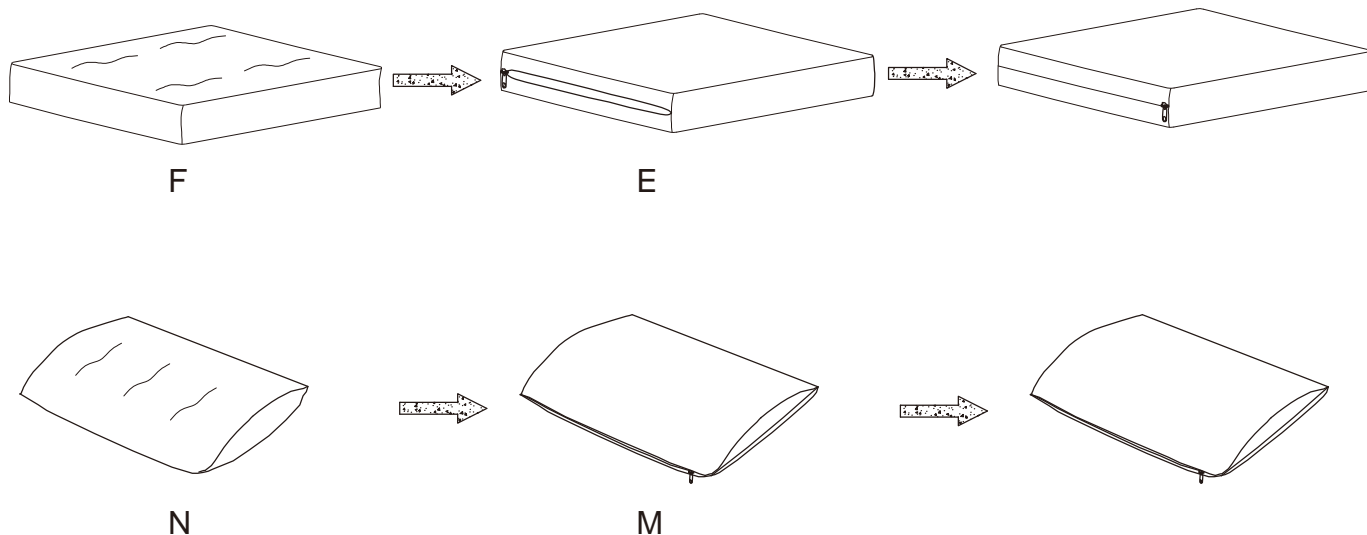

Step 7. Place seat cushion and back cushion as shown below.

