



# Assembly Instructions

Head board-Rivka

## Parts

NO.	Picture	Description	Size (mm)	QTY
A		Main Body	1960*680*100	1
B		Left Leg	670*150*60	1
C		Right Leg	670*150*60	1
D		Connecting Rod	670*70*18	2
E		Rail	1900*70*18	1
<b>Hardware</b>				
NO.	Picture	Description	Size (mm)	QTY
F		Bolt	M8*30	20
G		Flat Washer	M8*22*1.5	20
H		Allen Key	M5*40*70	1

STEP:1

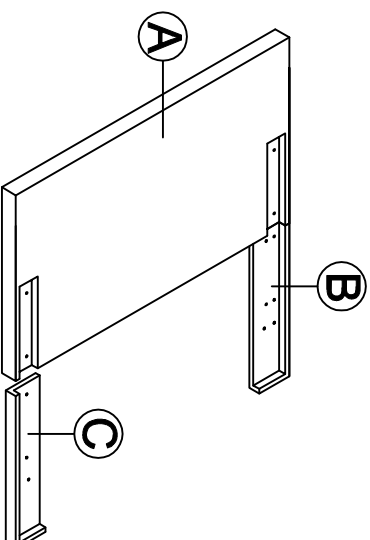

STEP:2

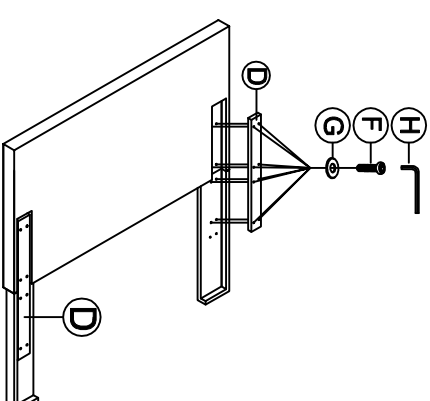

STEP:3

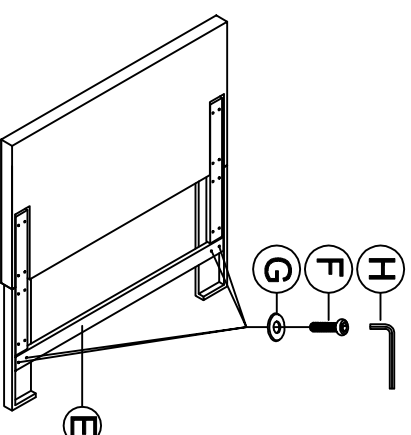

Use hardware F, G, assemble E, and lock them up with H.

Use hardware F, G, assemble A, B, C, D, and lock them up with H.

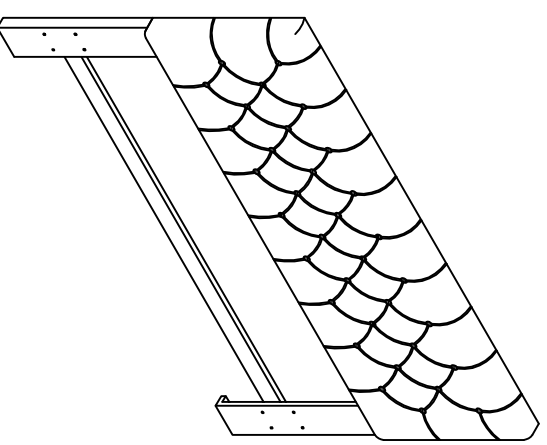

Overall Size: 77.25" x 53.25" x 4"



# Assembly Instructions

Head board-Rivka

## Parts

NO.	Picture	Description	Size (mm)	QTY
A		Main Body	1050*680*100	1
B		Left Leg	670*150*60	1
C		Right Leg	670*150*60	1
D		Connecting Rod	670*70*18	2
E		Rail	990*70*18	1
<b>Hardware</b>				
NO.	Picture	Description	Size (mm)	QTY
F		Bolt	M8*30	20
G		Flat Washer	M8*22*1.5	20
H		Allen Key	M5*40*70	1

STEP:1

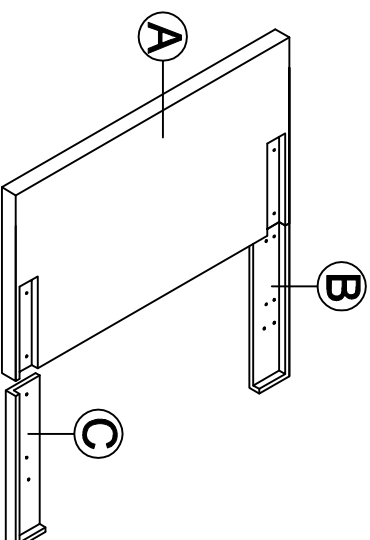

STEP:2

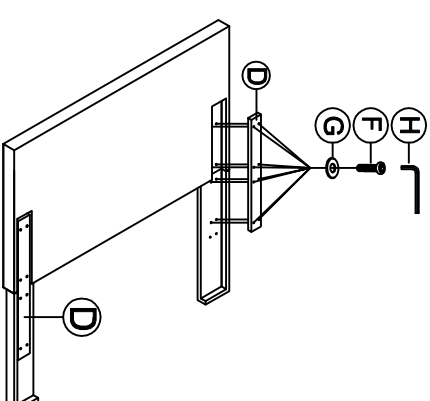

STEP:3

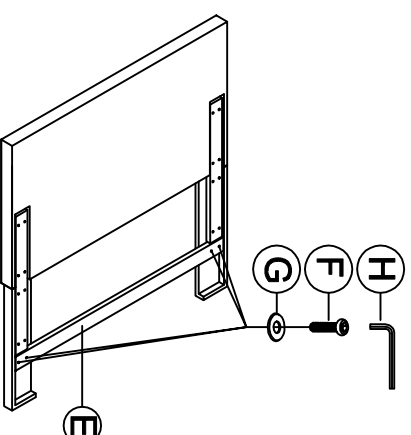

Use hardware F, G, assemble E, and lock them up with H.

Use hardware F, G, assemble A, B, C, D, and lock them up with H.

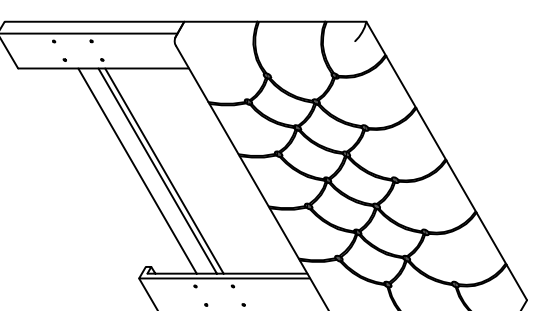

Overall Size: 41.25" x 53.25" x 4"



# Assembly Instructions

Head board-Rivka

## Parts

NO.	Picture	Description	Size (mm)	QTY
A		Main Body	1560*680*100	1
B		Left Leg	670*150*60	1
C		Right Leg	670*150*60	1
D		Connecting Rod	670*70*18	2
E		Rail	1500*70*18	1
<b>Hardware</b>				
NO.	Picture	Description	Size (mm)	QTY
F		Bolt	M8*30	20
G		Flat Washer	M8*22*1.5	20
H		Allen Key	M5*40*70	1

STEP:1

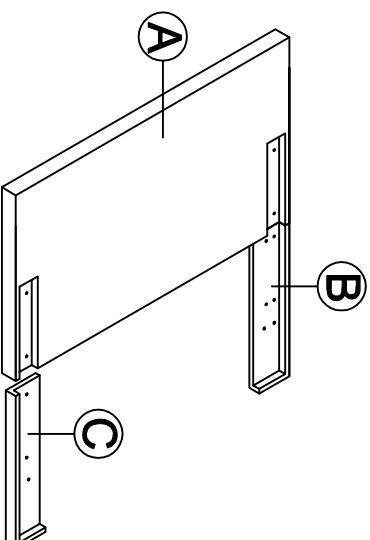

STEP:2

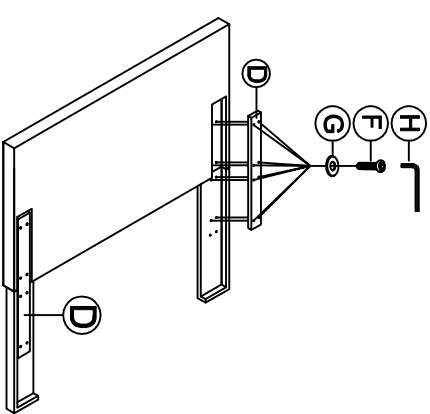

STEP:3

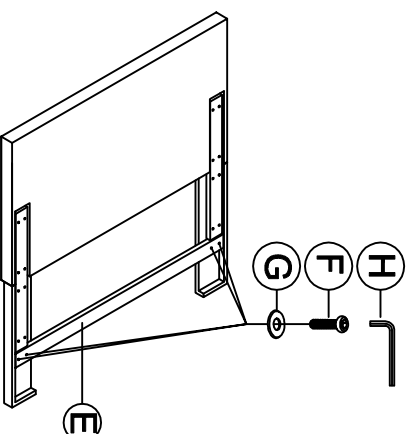

Use hardware F, G, assemble E, and lock them up with H.

Use hardware F, G, assemble A, B, C, D, and lock them up with H.

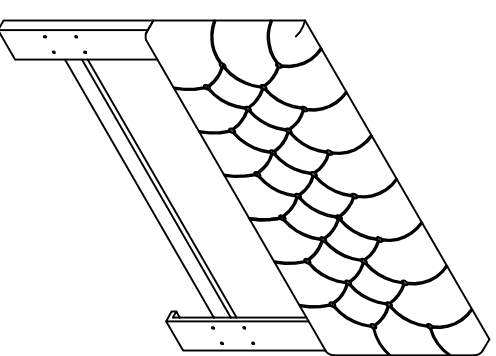

Overall Size: 61.5" x 53.25" x 4"