

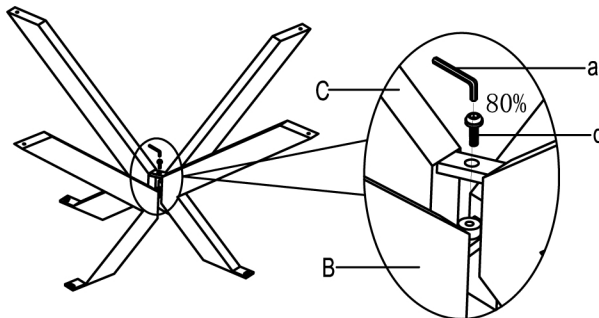

THANK YOU FOR PURCHASING THIS QUALITY PRODUCT.

BE SURE TO CHECK ALL PACKING MATERIAL CAREFULLY FOR SMALL PARTS THAT MAY HAVE COME LOOSE INSIDE THE CARTON DURING TRANSIT.

STEP 1 FASTEN THE BOLT d TO BE 80% TIGHT



PART LIST

NO	DESC	SIZE (MM)	SKETCH	QTY
A	TOP	1600x895x128		1PC
B	METAL BASE B	1278x625x40		1PC
C	METAL BASE B	1278x625x40		1PC

STEP 2

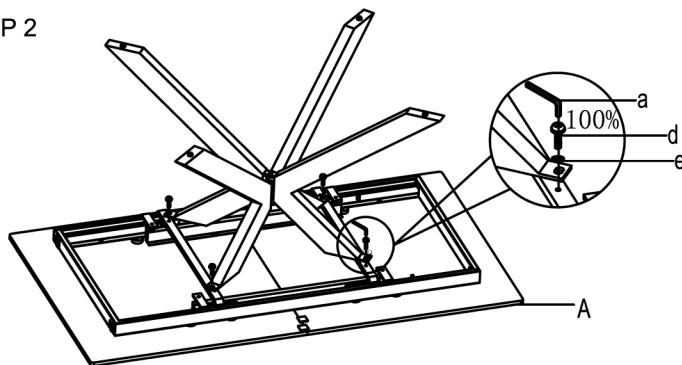

HARDWARE LIST

NO	DESC	SIZE (MM)	SKETCH	QTY
a	ALLEN KEY	6MM		1PC
b	ALLEN KEY	4MM		1PC
C	WRENCH	14MM		1PC
d	SCREW	M8x20		5PCS
e	FLAT	Φ22x11x2.0		4PCS

STEP 3 FASTEN THE BOLT d TO BE 100% TIGHT

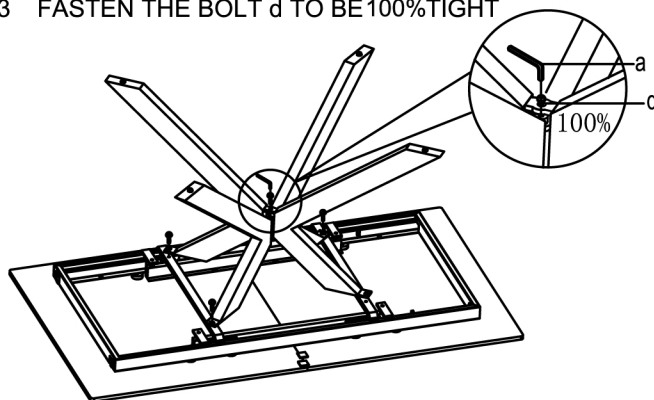

FINISHED

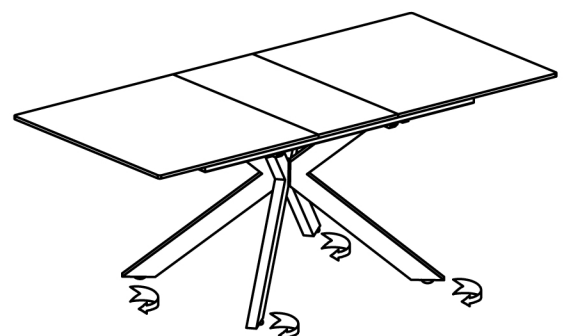

STEP 4

UNLOCK THE BRAKE ON GLIDE BEFORE OPEN THE EXTENSION LEAF.

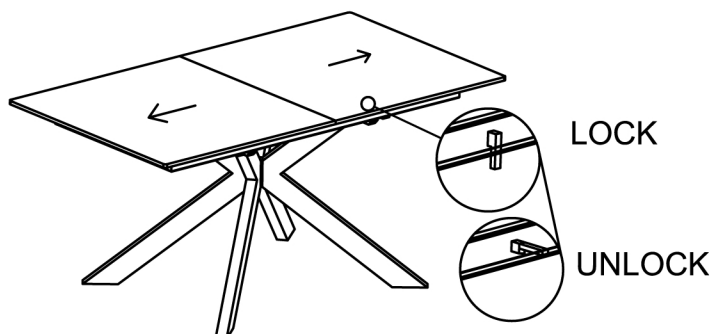

ADJUST THE GLIDES UNDERNEATH TO BALANCE THE TABLE

MADE IN CHINA

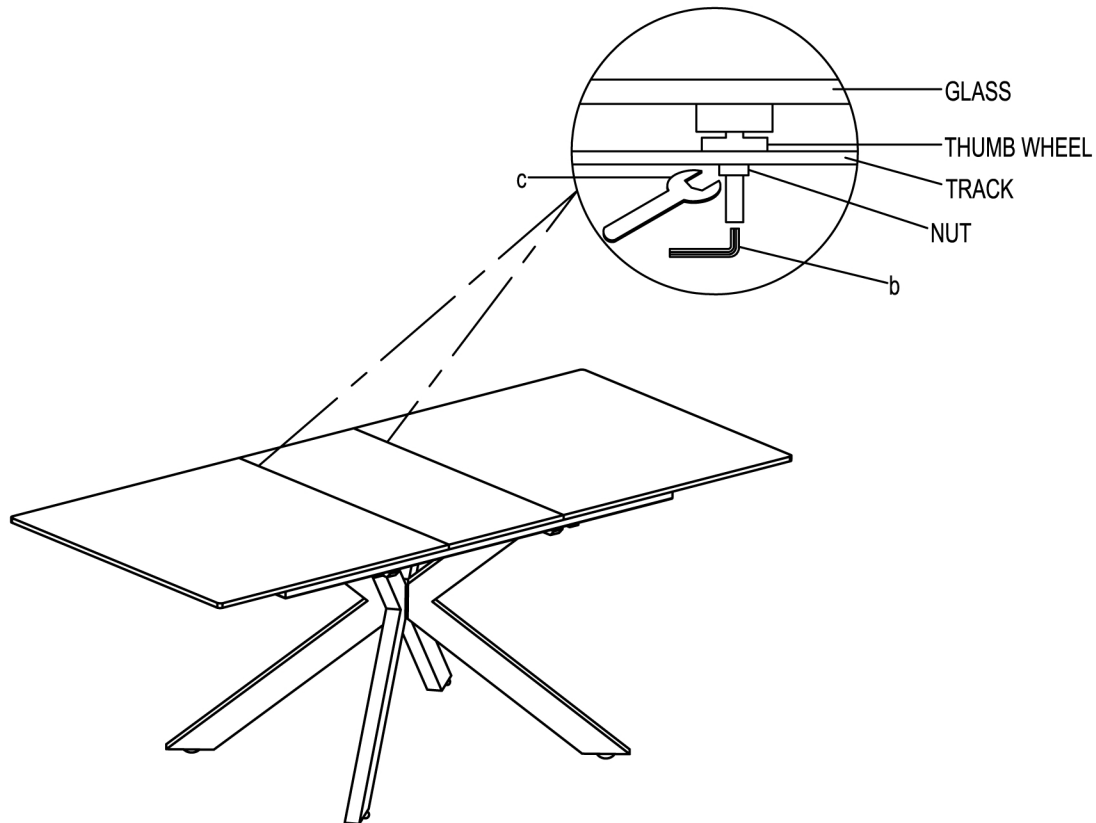

A. IF THE EXTENSION LEAF IS NOT LEVELED TO THE SIDE TOPS, PLEASE USE WRENCH *c* TO LOOSE THE 4 NUTS UNDERNEATH THE EXTENSION LEAF, AND TURN THE THUMB WHEELS TO LEVEL THE LEAF TO SIDE TOPS. FASTEN THE NUTS AFTER ADJUSTED.

B. IF THE EXTENSION LEAF IS NOT ALIGNED TO THE SIDE TOPS, PLEASE USE WRENCH *c* TO LOOSE THE 4 NUTS UNDERNEATH THE EXTENSION LEAF, AND 8 NUTS UNDERNEATH THE SIDE TOPS, AND MOVE THE TOPS AND EXTENSION A LITTLE BIT TO ALIGN ALL THE GLASS TOPS. FASTEN THE NUTS AFTER ADJUSTED.