

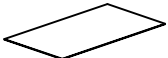



THANK YOU FOR PURCHASING THIS QUALITY PRODUCT.

BE SURE TO CHECK ALL PACKING MATERIAL CAREFULLY FOR SMALL PARTS THAT MAY HAVE COME LOOSE INSIDE THE CARTON DURING TRANSIT.



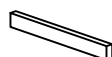

PART LIST

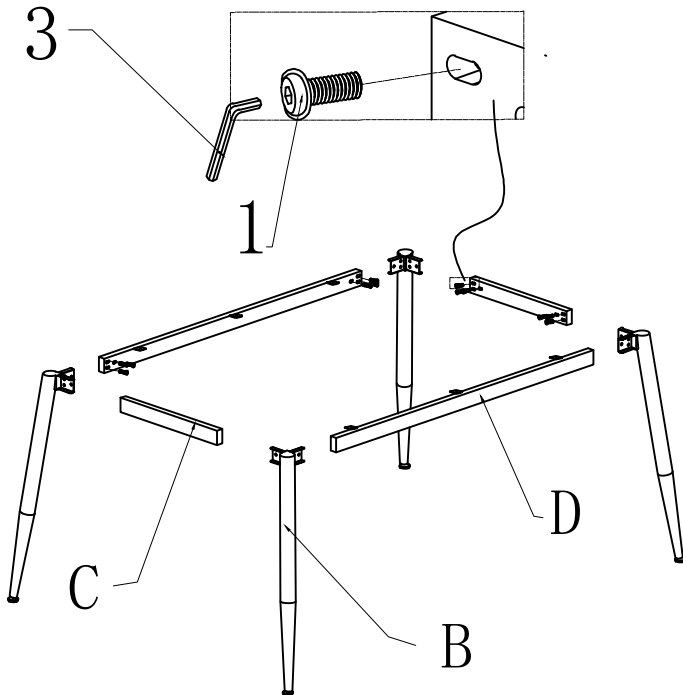
NO	DESC	SIZE (MM)	SKETCH	QTY
A	Desktop	1600*900*12		1PCS
B	Foot Post	745*50*50		4PCS
C	Short pipe	475*50*25		2PCS
D	Long Pipe	1275*50*25		2PCS

STEP 1



HARDWARE LIST

NO	DESC	SIZE (MM)	SKETCH	QTY
1	BOLT	M8*16		24 PCS
2	Suction Pad	M6		6 PCS
3	SPANNER	5MM		1PCS
4	NUT	M6		6 PCS

STEP 2

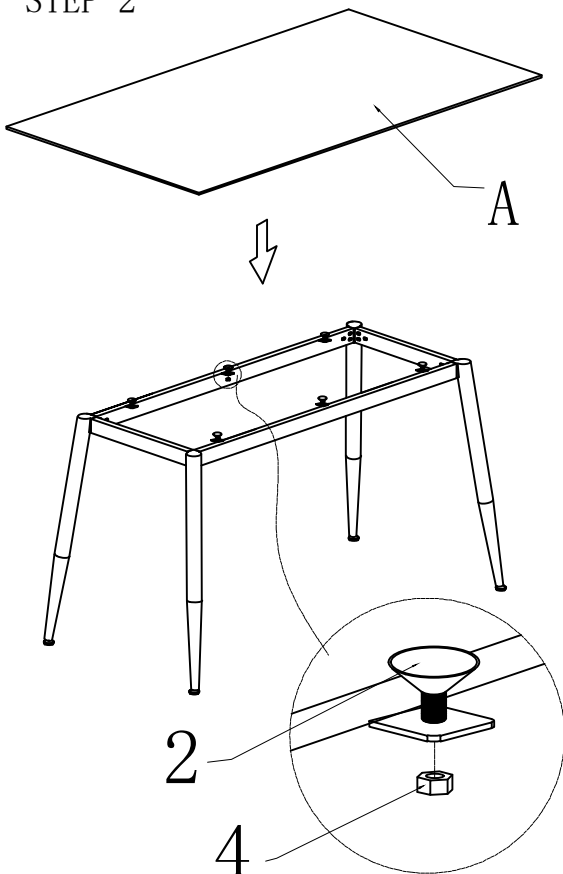

FINISHED

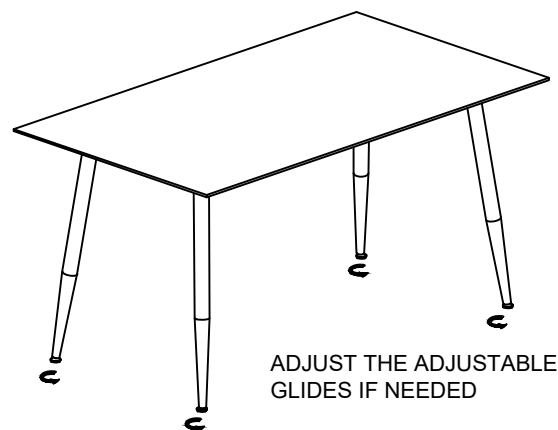

ADJUST THE ADJUSTABLE GLIDES IF NEEDED