

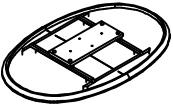

THANK YOU FOR PURCHASING THIS QUALITY PRODUCT.

BE SURE TO CHECK ALL PACKING MATERIAL CAREFULLY FOR SMALL PARTS THAT MAY HAVE COME LOOSE INSIDE THE CARTON DURING TRANSIT.

PART LIST

NO	DESC	SIZE (MM)	SKETCH	QTY
A	Top	1400X900X144		1PCS
B	Center Pillar	440X200X580		1PCS
C	Chassis	950X500X30		1PCS

STEP 1

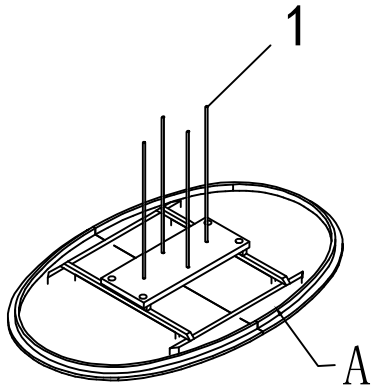



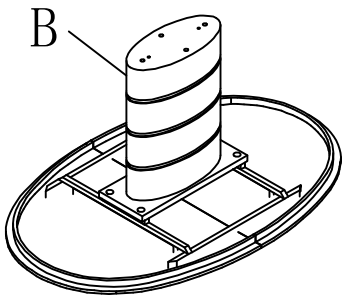

STEP 2

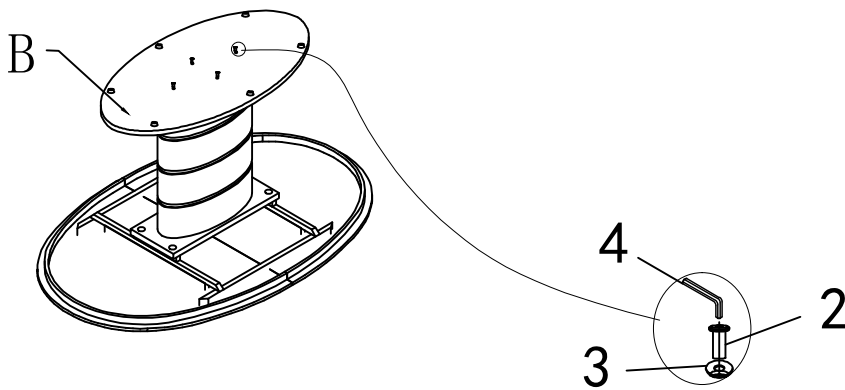

STEP 3



HARDWARE LIST

NO	DESC	SIZE (MM)	SKETCH	QTY
1	Screw Rod	M8*620		4 PCS
2	BOLT			4 PCS
3	Gaskets	Ø20*2		4 PCS
4	SPANNER	5MM		1PCS

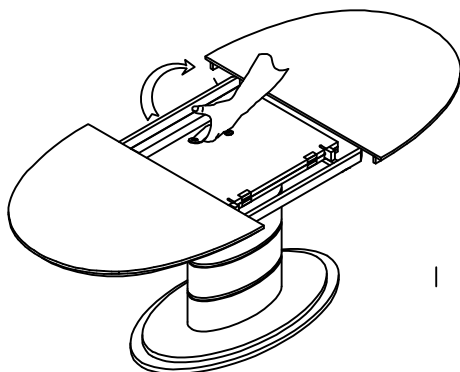
STEP 4

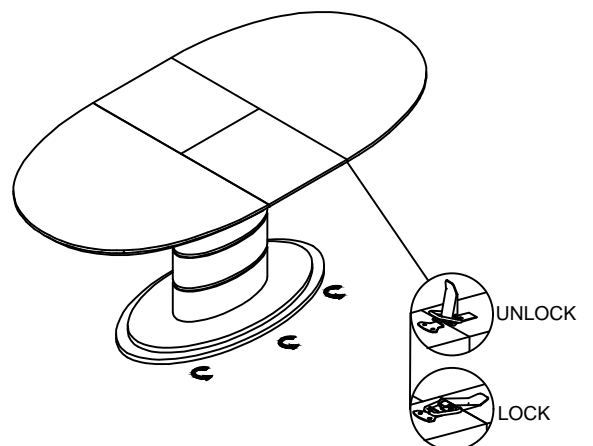

FINISHED



ADJUST THE ADJUSTABLE GLIDES IF NEEDED

MADE IN CHINA