

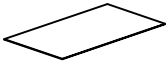





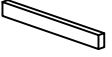

THANK YOU FOR PURCHASING THIS QUALITY PRODUCT.

BE SURE TO CHECK ALL PACKING MATERIAL CAREFULLY FOR SMALL PARTS THAT MAY HAVE COME LOOSE INSIDE THE CARTON DURING TRANSIT.

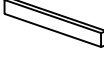
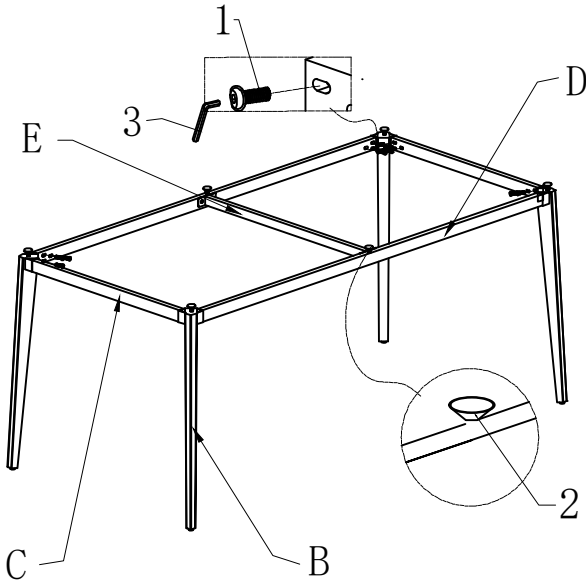
**PART LIST**

NO	DESC	SIZE (MM)	SKETCH	QTY
A	TOP	1795*895*12		1PCS
B	Foot Post	745*50*50		4PCS
C	Short pipe	680*40*20		2PCS
D	Long Pipe	1585*40*20		2PCS
E	Short pipe	755*40*20		1PCS

**STEP 1**

**HARDWARE LIST**

NO	DESC	SIZE (MM)	SKETCH	QTY
1	BOLT	M8*16		28 PCS
2	Suction Pad	M6		6 PCS
3	SPANNER	5MM		1PCS

