

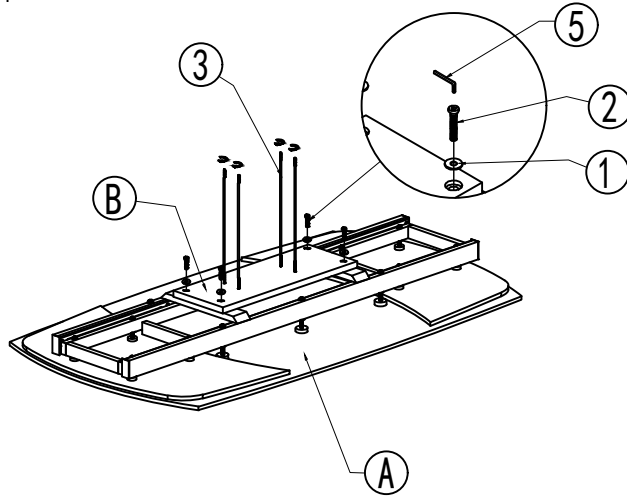

THANK YOU FOR PURCHASING THIS QUALITY PRODUCT
BE SURE TO CHECK ALL PACKING MATERIAL CAREFULLY FOR SMALL PARTS THAT MAY HAVE COME
LOOSE INSIDE THE CARTON DURING TRANSIT.

STEP 1



STEP 2

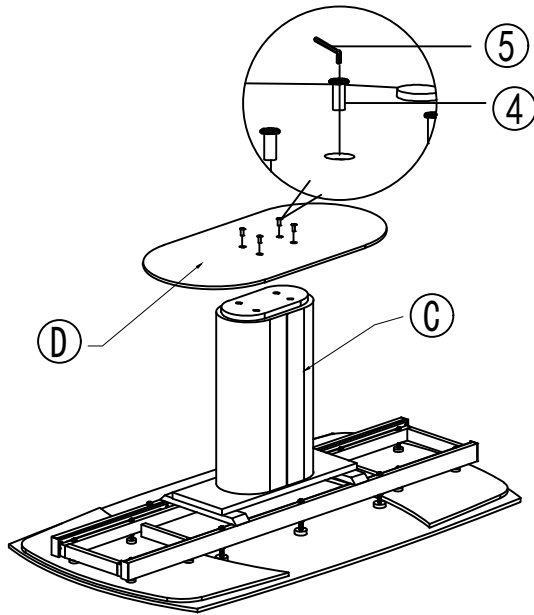

STEP 4

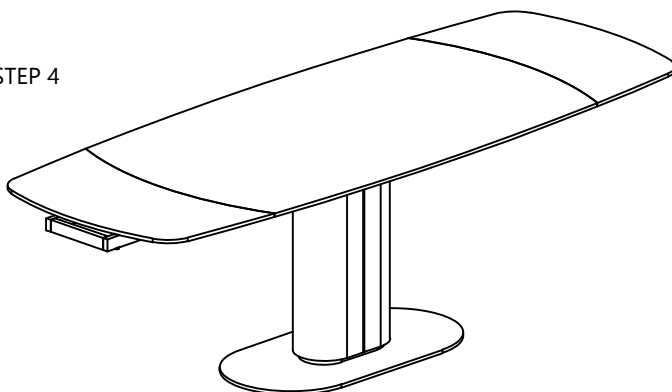

PART LIST

NO	DESC	SIZE (MM)	SKETCH	QTY
A	TABLE TOP	1600X900X120		1PC
B	CONNECTING BOARD	540X220X25		1PC
C	MIDDLE COLUMN	350X200X590		1PC
D	BASE	900X450X9		1PC

HARDWARE LIST

NO	DESC	SIZE(MM)	SKETCH	QTY
1	FLAT WASHER	ø8.3		4PCS
2	BOLT	M8x35		4PCS
3	LONG BOLT	M8 X 600mm		4PCS
4	NUT	Mx35		4PCS
5	SPANNER	5MM		1PC
6				

STEP 3

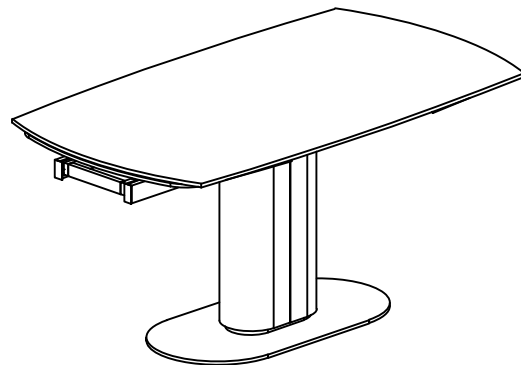

USE THE ADJUSTABLE GLIDES TO LEVEL
THE TABLES