







THANK YOU FOR PURCHASING THIS QUALITY PRODUCT.
 BE SURE TO CHECK ALL PACKING MATERIAL CAREFULLY FOR SMALL PARTS THAT MAY HAVE COME LOOSE INSIDE THE CARTON DURING TRANSIT.

PART LIST

NO	DESC	SIZE (MM)	SKETCH	QTY
A	TOP	1350X1350X24		1 PC
B	LEG	730X41X54		4 PC
C	RING	630X630X25		1 PC

HARDWARE LIST

NO	DESC	SIZE (MM)	SKETCH	QTY
1	SPANNER	5 #		1PC
2	BOLT	M8x16		24 PC
3	FLAT WASHER	16x8.3		24 PC

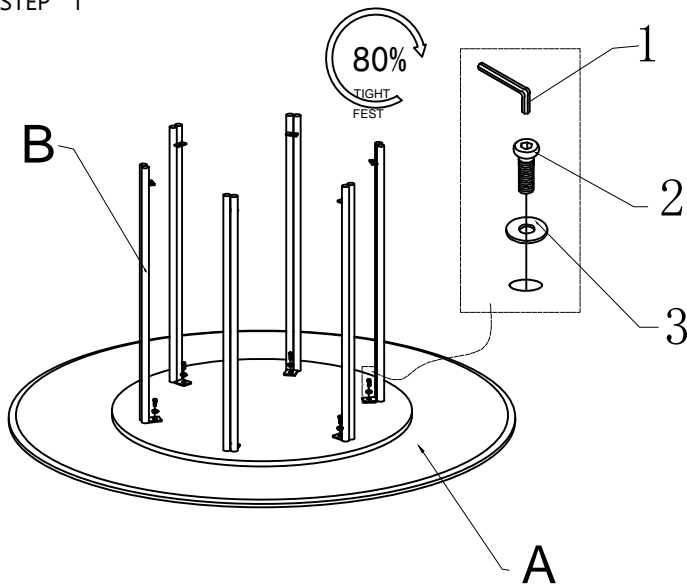
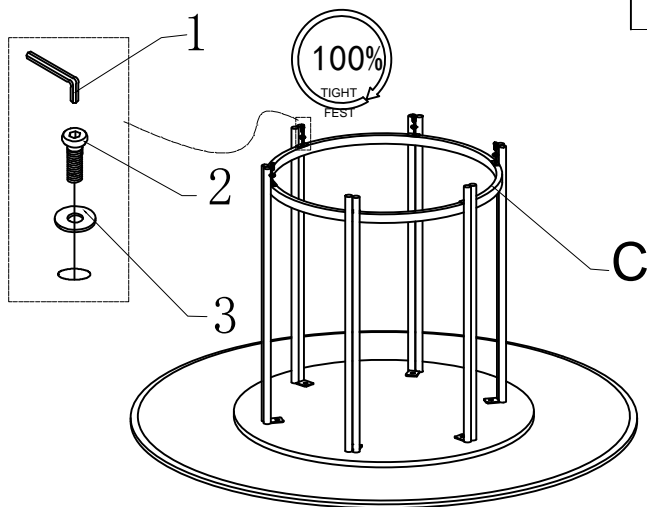
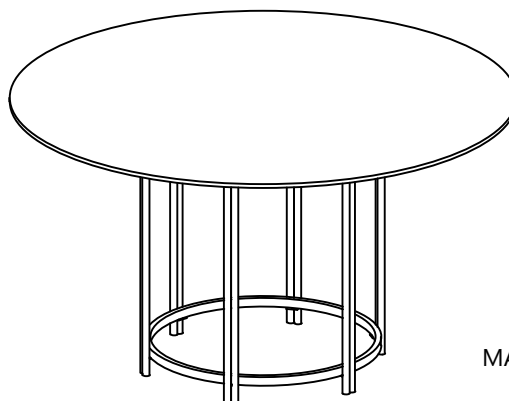
STEP 1

STEP 2

FINISHED

MADE IN CHINA