

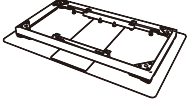





THANK YOU FOR PURCHASING THIS QUALITY PRODUCT.

BE SURE TO CHECK ALL PACKING MATERIAL CAREFULLY FOR SMALL PARTS THAT MAY HAVE COME LOOSE INSIDE THE CARTON DURING TRANSIT.

PART LIST

NO	DESC	SIZE (MM)	SKETCH	QTY
A	Desktop	1400*800*10		1PCS
B	Leg	745*50*50		4PCS

HARDWARE LIST

NO	DESC	SIZE (MM)	SKETCH	QTY
1	SCREW	M8*16		12 PCS
2	ALLEN KEY	5MM		1PCS
3	GLIDES	M6		4 PCS
4	WRENCH_1	#14		1PCS
5	WRENCH_2	#10		1PCS

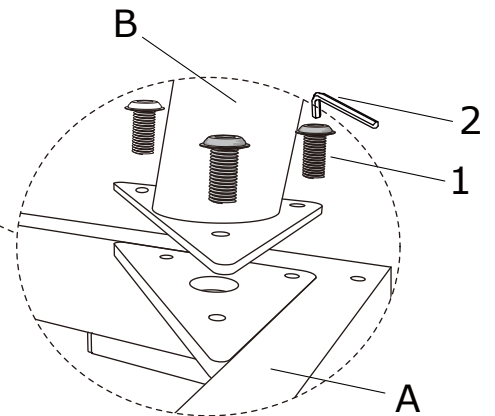
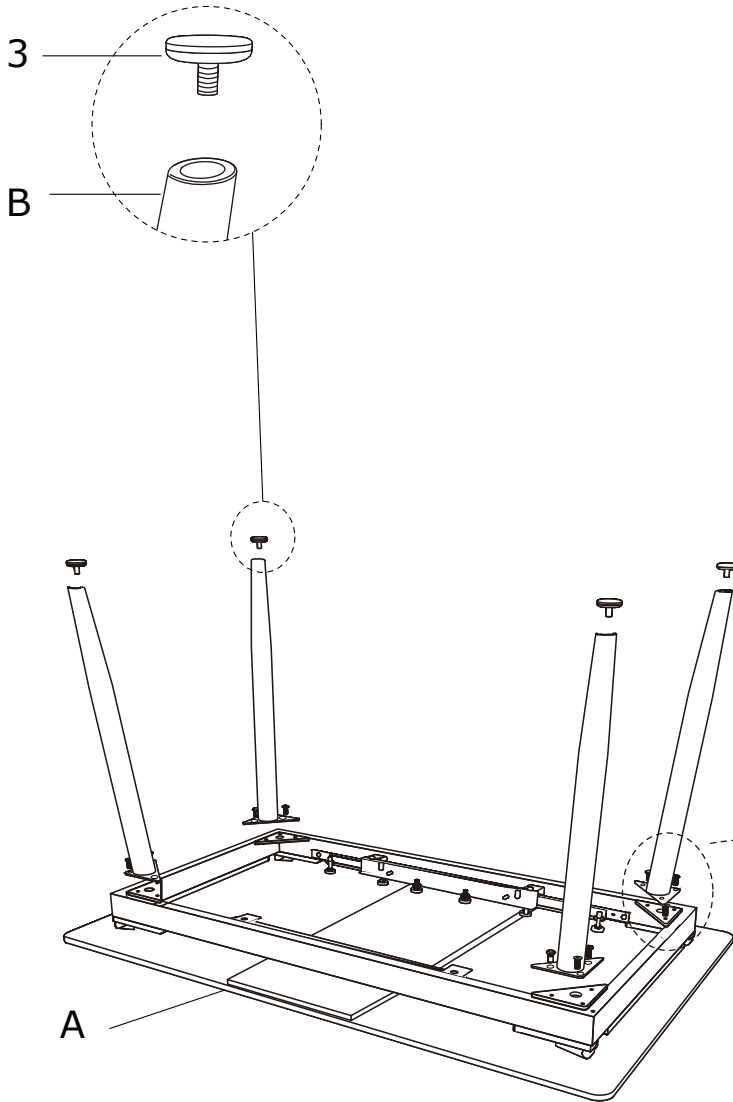
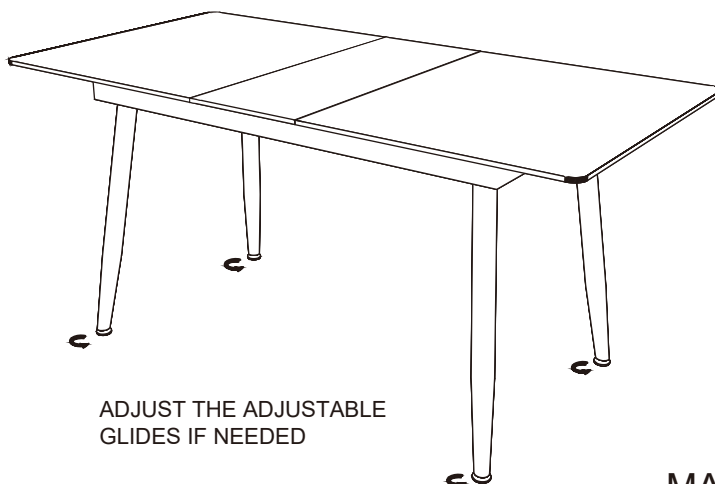
STEP 1

STEP 2

FINISHED

 ADJUST THE ADJUSTABLE
 GLIDES IF NEEDED



Adjustment Instruction

- A IF THE SLAB TOPS ARE NOT LEVELED WELL, PLEASE USE ⑤ TO LOOSE THE BELOW NUT, AND ADJUST THE ABOVE NUT BY ④ TO LEVEL THE TOPS.
- B IF THE SLAB TOPS ARE NOT ALIGNED WELL, PLEASE USE ⑤ TO LOOSE THE BELOW NUT, AND MOVE THE TOP A LITTLE BIT TO ALIGN THE TOPS.

