

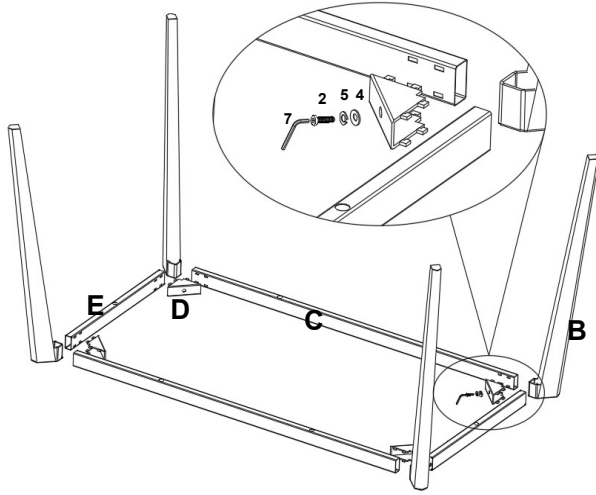

THANK YOU FOR PURCHASING THIS QUALITY PRODUCT.

BE SURE TO CHECK ALL PACKING MATERIAL CAREFULLY FOR SMALL PARTS THAT MAY HAVE COME LOOSE INSIDE THE CARTON DURING TRANSIT.

STEP 1



PART LIST

NO	DESC	SIZE (MM)	SKETCH	QTY
A	CERAMICS TOP	1400X800		1 PC
B	METAL FEET	735X180X40		4PC
C	METAL CONNECTORS	72X72X30		4PC
D	METAL CONNECTORS	1070X40X20		2PC
E	METAL CONNECTORS	482X40X20		2 PC

STEP 2

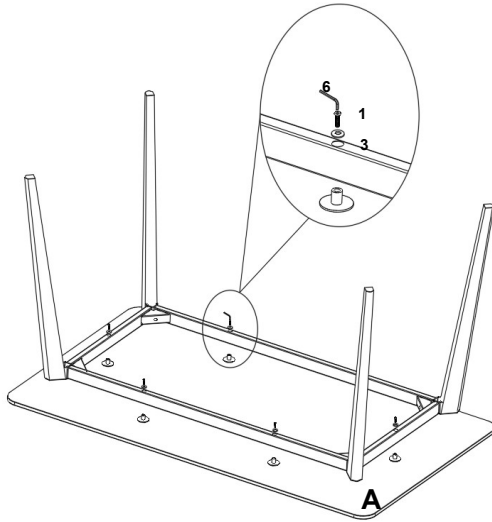

HARDWARE LIST

NO	DESC	SIZE (MM)	SKETCH	QTY
1	SCREW	M6X40		6PCS
2	SCREW	M8X60		4PCS
3	PLAT WASHER	M6		6PC
4	PLAT WASHER	M8		4PC
5	SPRING WASHER	M8		4PCS
6	SPANNER	M6		1PCS
7	SPANNER	M8		1PCS

FINISHED

