

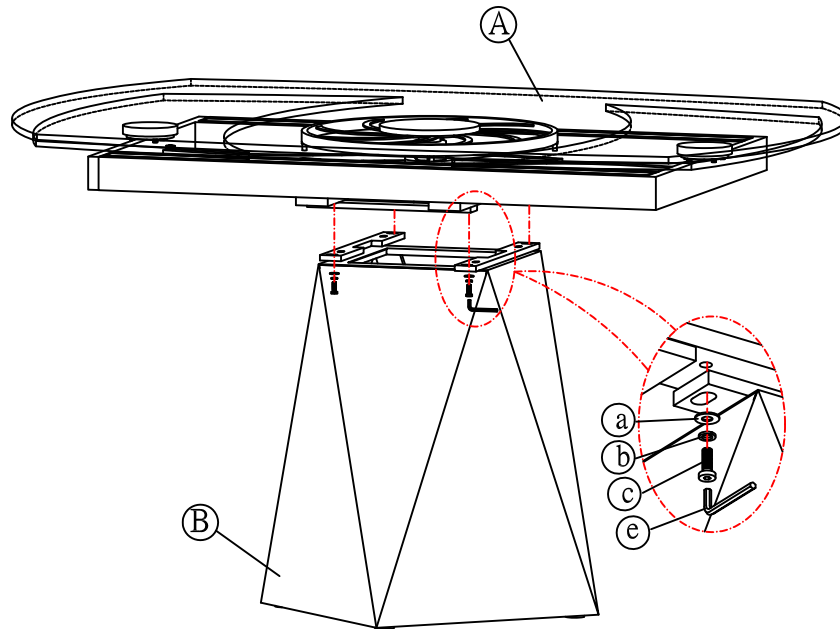

THANK YOU FOR PURCHASING THIS QUALITY PRODUCT.

BE SURE TO CHECK ALL PACKING MATERIAL CAREFULLY FOR SMALL PARTS THAT MAY HAVE COME LOOSE INSIDE THE CARTON DURING TRANSIT.

Step 1



FINISH

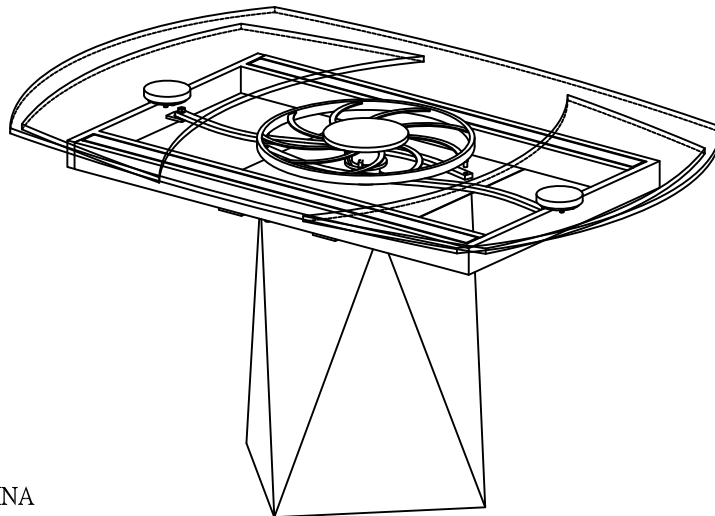

HARDWARE LIST:

NO	DESCRIPTION	SIZE(mm)	SKETCH	QTY
a	WASHER	φ8.5		4PCS
b	SPRING WASHER	φ8.5		4PCS
c	BOLT	M8x25		4PCS
d	ALLEN KEY	4		1PC
e	ALLEN KEY	5		1PC
f	WRENCH	13		1PC

PARTS LIST:

NO	DESCRIPTION	SIZE(mm)	SKETCH	QTY
A	TABLE TOP	1500*1000		1PC
B	BASE	450*450*635		1PC



Step 4

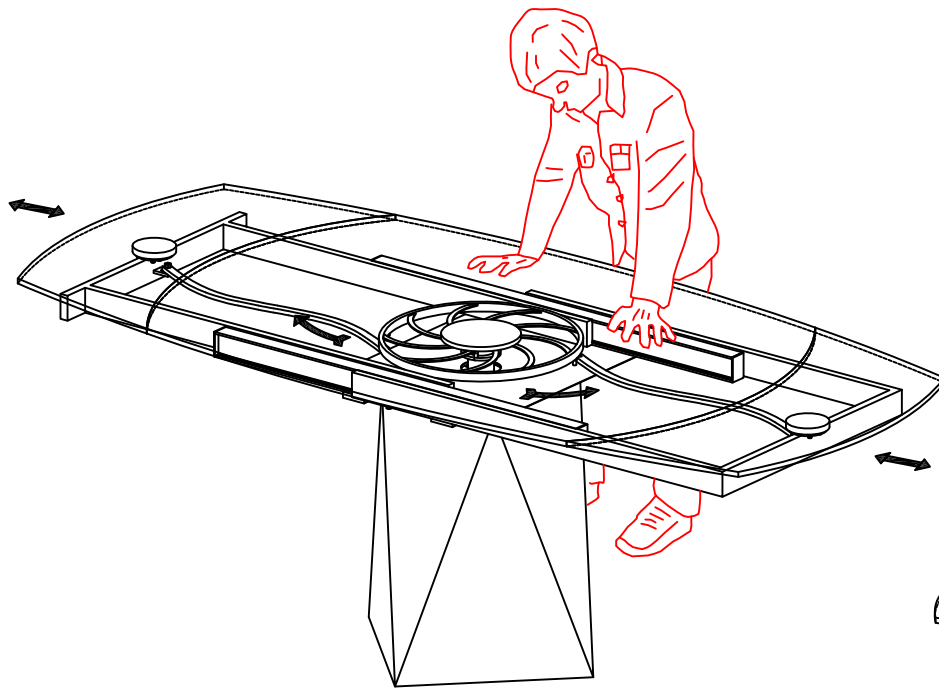

IF THE 2 EXTENSION TOPS ARE NOT LEVELING WELL TO THE MIDDLE TOP, OR DOWNWARD AT THE END AFTER EXTENDED, USE THE ALLEN KEY (e) TO LOOSE THE 3 BOLT A LITTLE BIT, USE THE ALLEN KEY (d) TO ADJUST THE 4 NUT SCREWS TO BALANCE THE EXTENSION TOPS, AND THEN FASTEN THE BOLTS.

