

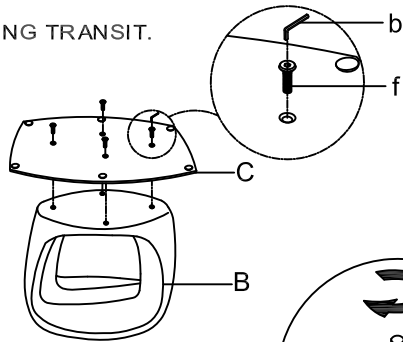

THANK YOU FOR PURCHASING THIS QUALITY PRODUCT.

BE SURE TO CHECK ALL PACKING MATERIAL CAREFULLY FOR SMALL PARTS THAT MAY HAVE COME LOOSE INSIDE THE CARTON DURING TRANSIT.

STEP 1



STEP 2

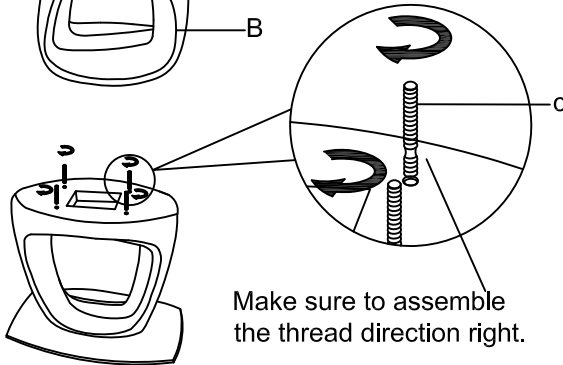

Make sure to assemble the thread direction right.

STEP 3

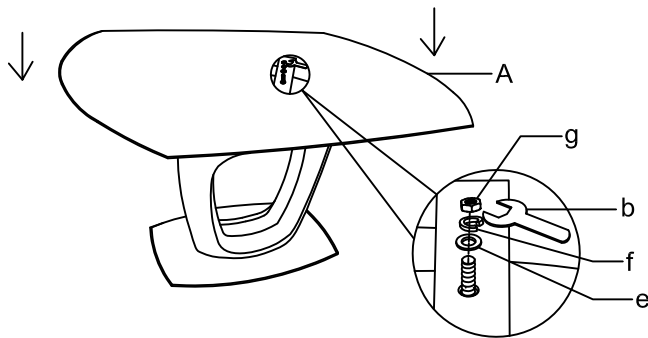

STEP 4

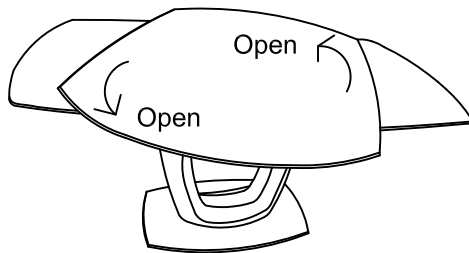

Extend by anti-clockwise rotating, and close by clockwise rotating

STEP 5

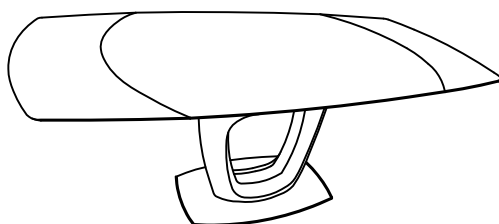

FINISHED

MADE IN CHINA

PART LIST

NO	DESC	SIZE (MM)	SKETCH	QTY
A	TOP	1400X1000X120		1PC
B	PEDESTAL	640X320X620		1PC
C	BASE	900X480X8		1PC

HARD WARE LIST

NO	DESC	SIZE (MM)	SKETCH	QTY
a	SPANNER	5MM		1PC
b	WRENCH	14MM		1PC
c	LONG BOLT	M8X55		4PCS
d	SCREW	M8X25		4PCS
e	FLAT WASHER	φ20xφ8.3x2.0		4PCS
f	SPRING WASHER	φ13xφ8.3x2.0		4PCS
g	NUT	M8		4PCS



HARD WARE LIST

NO	DESC	SIZE (MM)	SKETCH	QTY
h	SPANNER	4MM		1PC
i	WRENCH	12MM		1PC

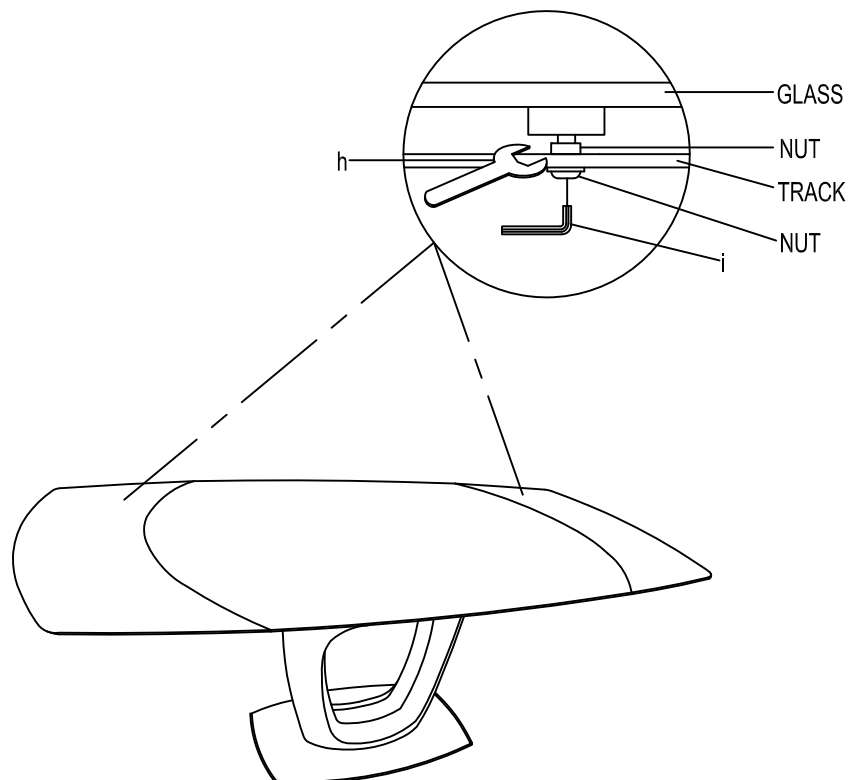

A. IF THE EXTENSION PANNEL IS NOT LEVELED TO THE TABLE TOPS, PLEASE USE h TO LOOSE THE 4 NUTS UNDERNEATH THE TRACK, AND USE i TO TURN THE NUTS TO LEVEL THE SIDE PANNEL WITH TABLE TOP. FASTEN THE NUTS AFTER ADJUSTED.

B. IF THE SIDE PANNEL IS NOT ALIGNED TO THE TABLE TOP, PLEASE USE h TO LOOSE THE 4 NUTS UNDERNEATH THE TRACK AND USE i TO LOOSE 8 NUTS UNDERNEATH THE SIDE PANNEL, AND MOVE THE TABLE TOP AND PANNEL A LITTLE BIT TO ALIGN ALL THE GLASS TOPS. FASTEN THE NUTS AFTER ADJUSTED.