

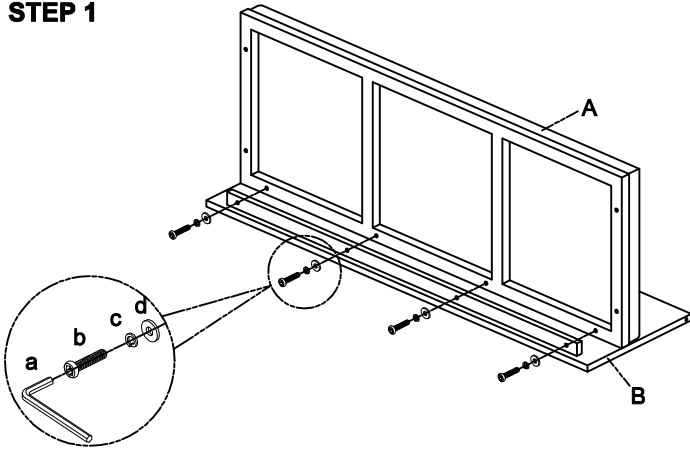

THANK YOU FOR PURCHASING THIS QUALITY PRODUCT.

BE SURE TO CHECK ALL PACKING MATERIAL CAREFULLY FOR SMALL PARTS THAT MAY HAVE COME LOOSE INSIDE THE CARTON DURING TRANSIT.

STEP 1



STEP 2

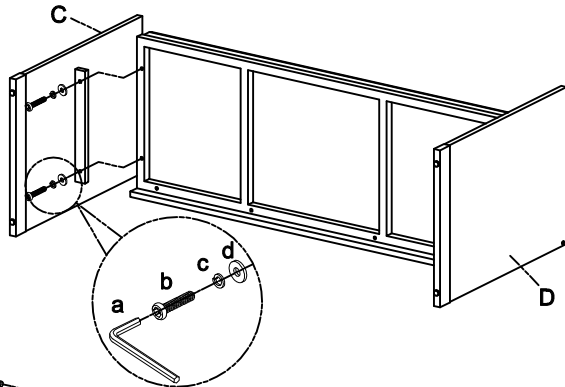

STEP 3

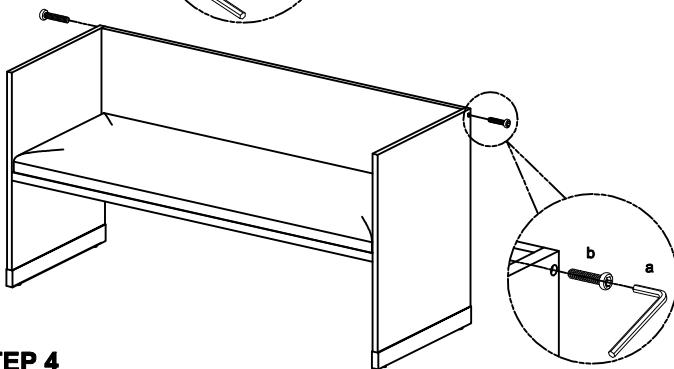

STEP 4

For fixing better the corner cover to the assembled bench, remove the paper of double glued tape inside of the corner cover before putting on to the bench corner.

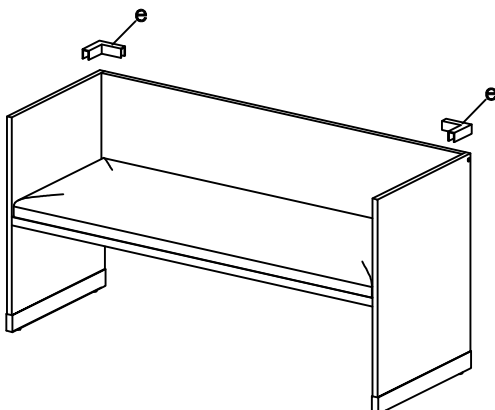

PART LIST

NO	DESC	SIZE (MM)	SKETCH	QTY
A	Seat	1470x430x155		1 PC
B	Back Plane	1460x430x18		1 PC
C	Left Side Plane	760x550x18		1 PC
D	Right Side Plane	760x550x18		1 PC

HARDWARE LIST

NO	DESC	SIZE (MM)	SKETCH	QTY
a	Allen Key	4mm		1PC
b	Bolt	6x31.8mm		10PCS
c	Spring Washer	6mm		8PCS
d	Flat Washer	6x16mm		8PCS
e	Corner Cover	100x20x30mm		2PCS

FINISHED

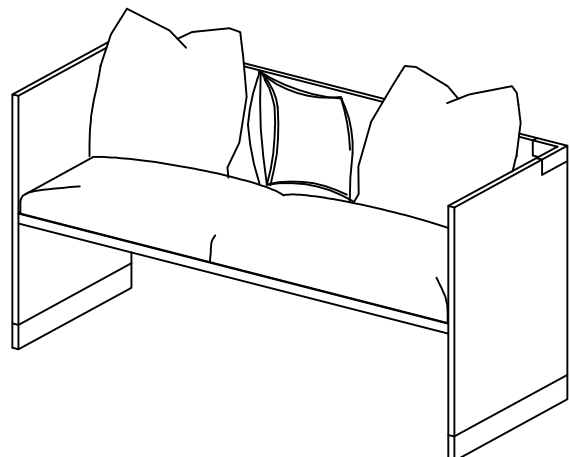

Note: Confirm bench is level and adjust the adjustable glides if needed.