



Chintaly Imports.

Assembly Instruction

ITEM NO: BETHANY-NOOK

Thank you for purchasing this quality product. Be sure to check all packing material carefully for small parts that may have come loose inside the carton during shipment.

STEP 1

Secure bolt (a) into 80% when assembly leg_1 (PART C) with Allen Key (h).

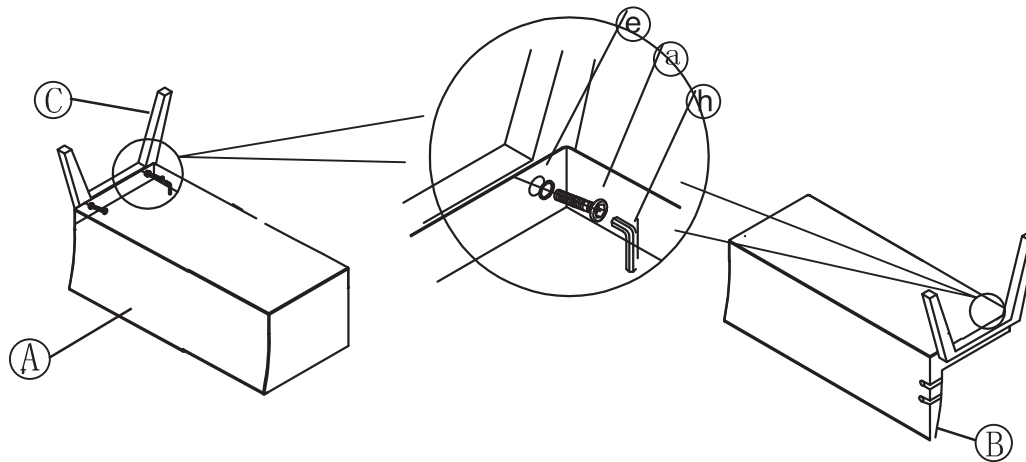

STEP 2

Secure bolt (b) into 80% when assembly metal plate (c) for leg_1 (PART C) with Allen Key (g), but tightly secure wood screw (d) for Leg_2 (PART D).

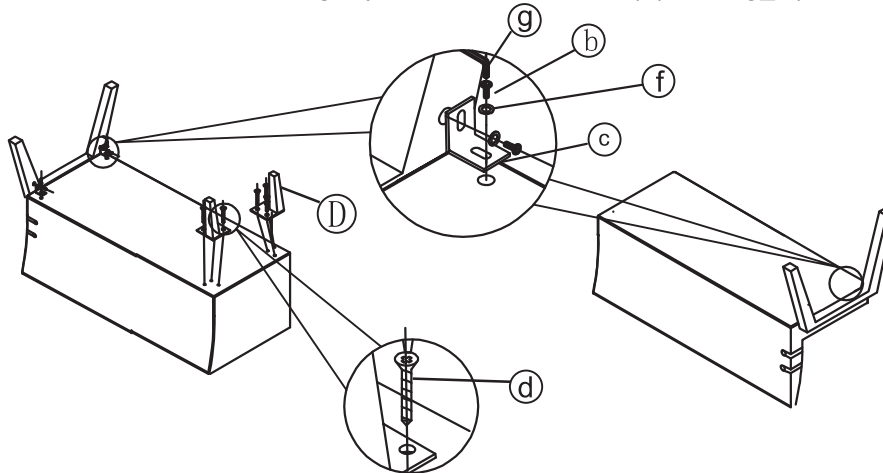

PARTS LIST:

NO	DESCRIPTION	SKETCH	QTY
A	3 SEATER		1PC
B	CORNER		1PC
C	LEG_1		2PC
D	LEG_2		2PC

HARD WARE LIST:

NO	DESCRIPTION	SKETCH	QTY
a	BOLT_1	M8x114	4PC
b	BOLT_2	M6x22	8PC
c	METAL PLATE_2		4PC
d	WOOD SCREW	M4x39	8PC
e	FLAT WASHER_1	Ø22/Ø8	4PC
f	FLAT WASHER_2	Ø16/Ø6	8PC
g	ALLEN KEY_1	4#	1PC
h	ALLEN KEY_2	5#	1PC



Chintaly Imports.

Assembly Instruction

ITEM NO: BETHANY-NOOK

Thank you for purchasing this quality product. Be sure to check all packing material carefully for small parts that may have come loose inside the carton during shipment.

STEP 3

Upside PART A and B after assembly legs, and hook them up.

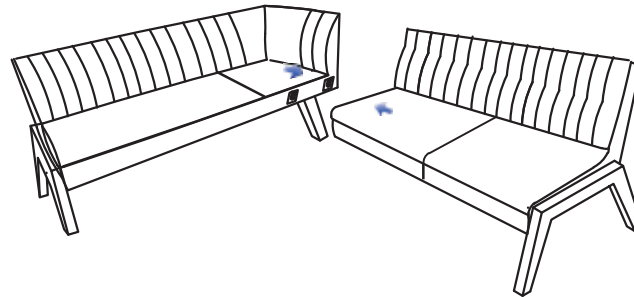

FINISH

Confirm the product is level on the ground and adjust the adjustable glides if needed, then tighten all bolt (a) and bolt (b) on leg_1 (PART C) completely.

