



THANK YOU FOR PURCHASING THIS QUALITY PRODUCT.

BE SURE TO CHECK ALL PACKING MATERIAL CAREFULLY FOR SMALL PARTS THAT MAY HAVE COME LOOSE INSIDE THE CARTON DURING TRANSIT.

STEP 1

Tight the bolt(b) 80% only

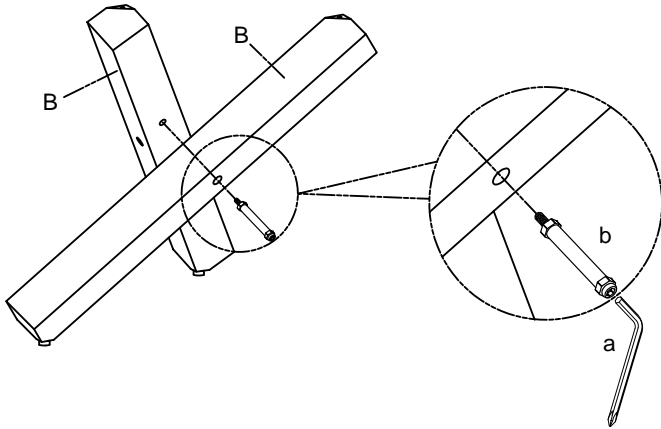

PART LIST

NO	DESC	SIZE (MM)	SKETCH	QTY
A	Glass Top	DIA700x10		1 PC
B	Metal Leg	730x60x60		3PC

HARDWARE LIST

NO	DESC	SIZE (MM)	SKETCH	QTY
a	Allen Key	4mm		1PC
b	Bolt	8x75mm		3PCS
c	Screws	M6		3PCS
d	Screws	4mm		3PCS

STEP 2

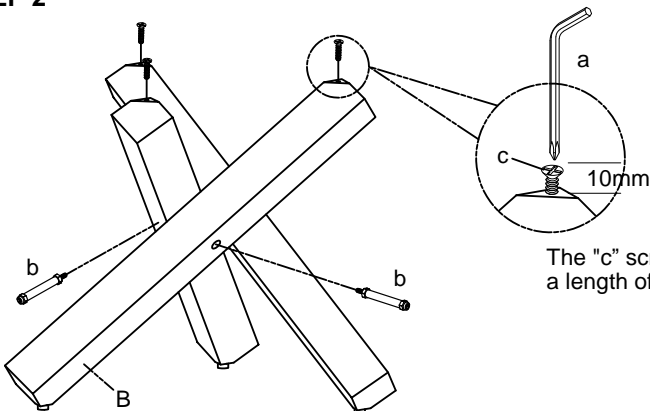

The "c" screw no need to be locked to the bottom when assembly, a length of 10mm should be set aside.

FINISHED

STEP 3

After tightening screws(d) then tight bolts(b) 100%

