

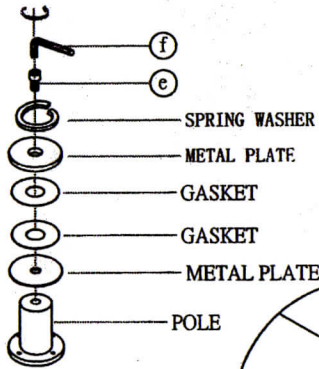

Step 1

UNASSEMBLE THE POLES



Step 2

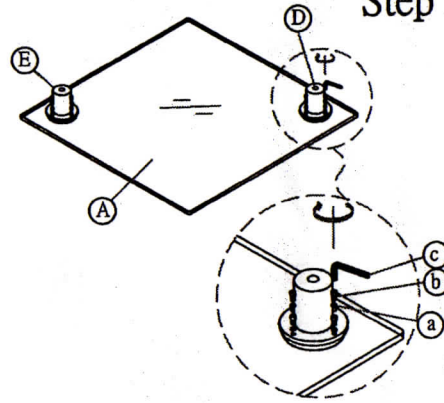

Step 3

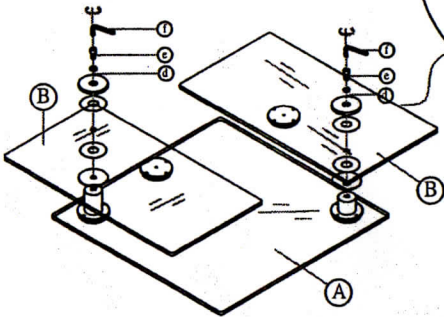

Step 4

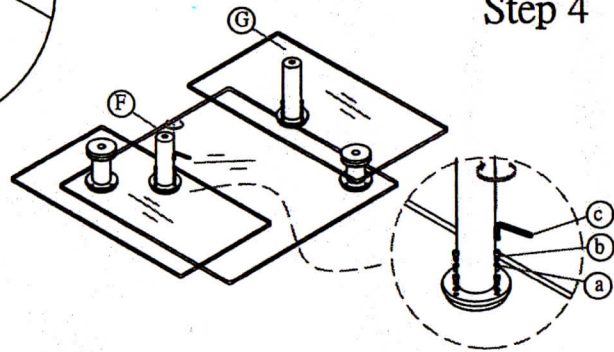

Step 5

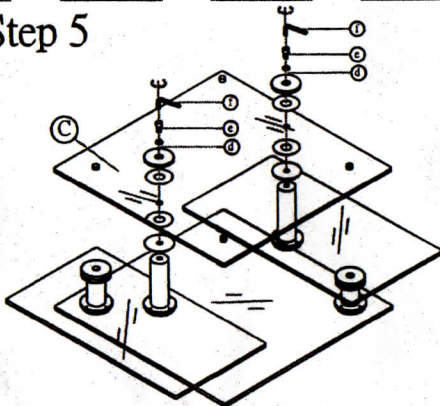

FINISH

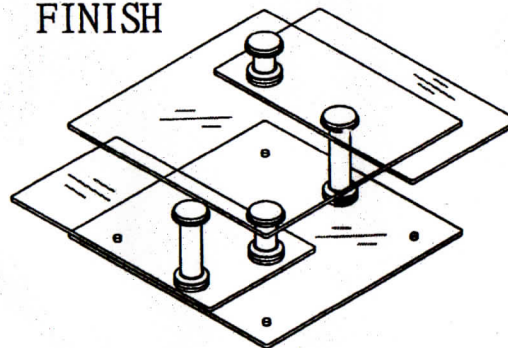

PARTS LIST:

NO	DESCRIPTION	SKETCH	QTY
A	GLASS TOP		1PC
B	GLASS SHELF		2PCS
C	GLASS BASE		1PC
D	POLE 72MM		1PC
E	POLE 102MM		1PC
F	POLE 200MM		1PC
G	POLE 230MM		1PC

HARDWARE LIST:

NO	DESCRIPTION	SKETCH	QTY
a	SMALL SPRING WASHER		16PCS
b	SMALL BOLT		16PCS
c	ALLEN KEY 5mm		1PC
d	LARGE SPRING WASHER		4PCS
e	LARGE BOLT		4PCS
f	ALLEN KEY 14mm		1PC