

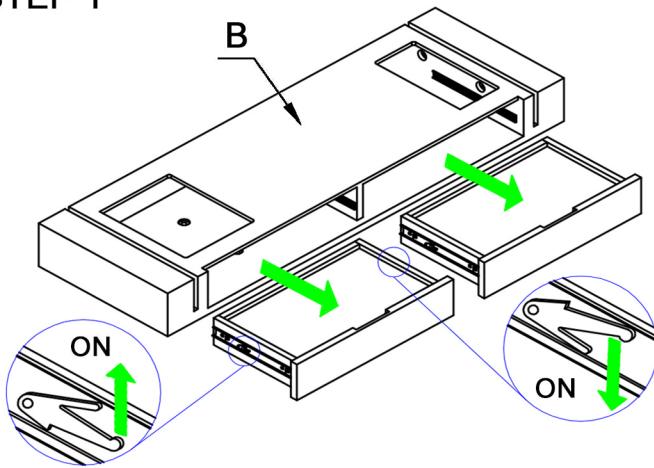

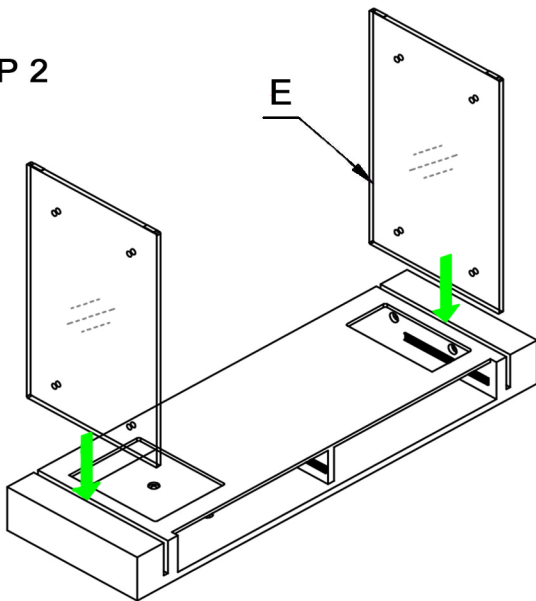

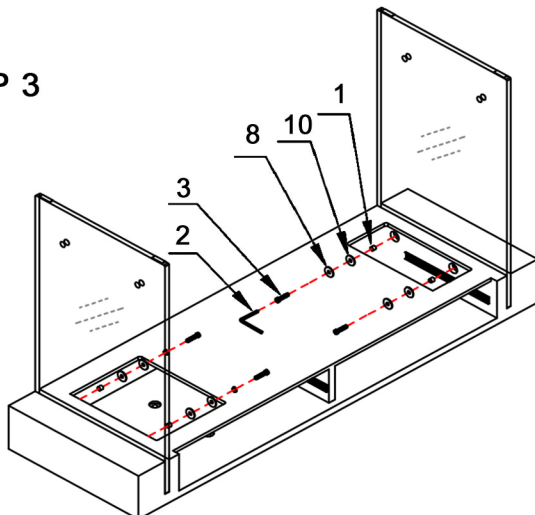



THANK YOU FOR PURCHASING THIS QUALITY PRODUCT.
 BE SURE TO CHECK ALL PACKING MATERIAL CAREFULLY FOR SMALL PARTS THAT MAY HAVE COME LOOSE INSIDE THE CARTON DURING TRANSIT.













STEP 1

STEP 2

STEP 3

Fasten B to E, with (3), (8), (10), (1) by (2).
 Repeat the same step to other 3 screw holes on B.

PART LIST

NO	DECS	SIZE (MM)	SKETCH H	QTY
A	TOP	1350*500*52		1PC
B	CABINET	1200*390*120		1PC
C	BASE-1	1016*390*52		1PC
D	BASE-2	390*80*50		2PCS
E	GLASS BASE-1	633*390*12		2PCS
F	GLASS BASE-2	755*455*12		1PC
G	BOX	250*250*36		1PC

HARDWARE LIST

NO	DECS	SIZE (MM)	SKETCH	QTY
1	GASKET	Φ11*1.5*11		11PCS
2	ALLEN KEY	M5		1PC
3	SCREW-1	M8*35		7PCS
4	SCREW-2	M8*65		4PCS
5	SCREW-3	M8*50		4PCS
6	SCREW-4	M8*16		4PCS
7	SPRING WASHER	Φ13*2*Φ9		3PCS
8	FLAT WASHER-1	Φ22*2*Φ8		7PCS
9	FLAT WASHER-2	Φ17*1.5*Φ8		8PCS
10	CUSHION	Φ19*1*Φ8		7PCS
11	SWIVEL	200*200*25		1PC
12	NUT	M8		4PCS
13	HEXAGON SOCKET	14#		1PC

STEP 4

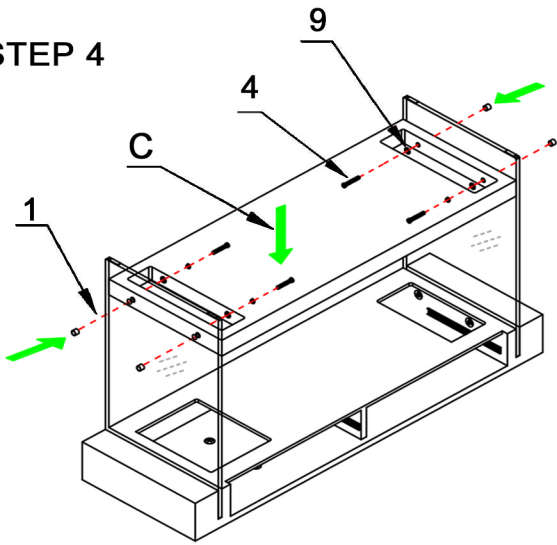

STEP 5

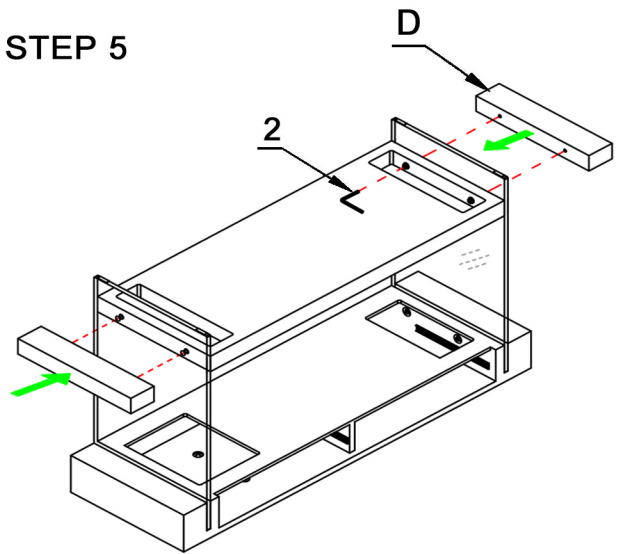

STEP 6

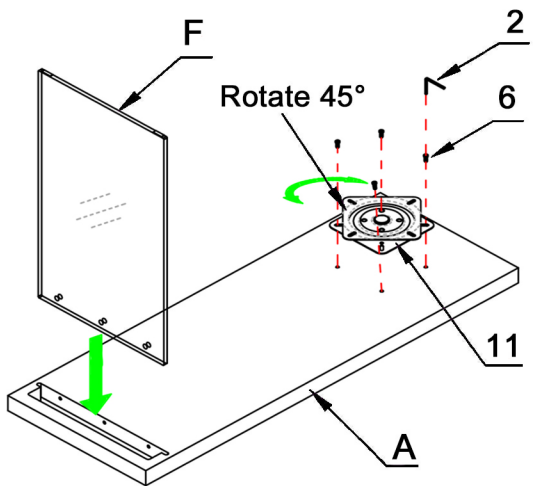

STEP 7

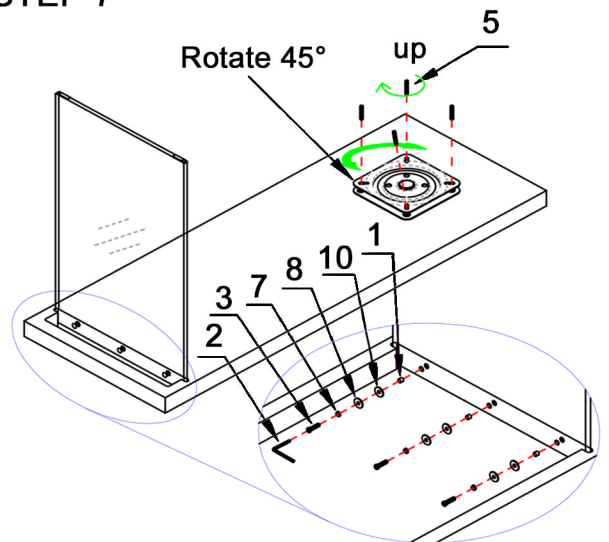

STEP 8

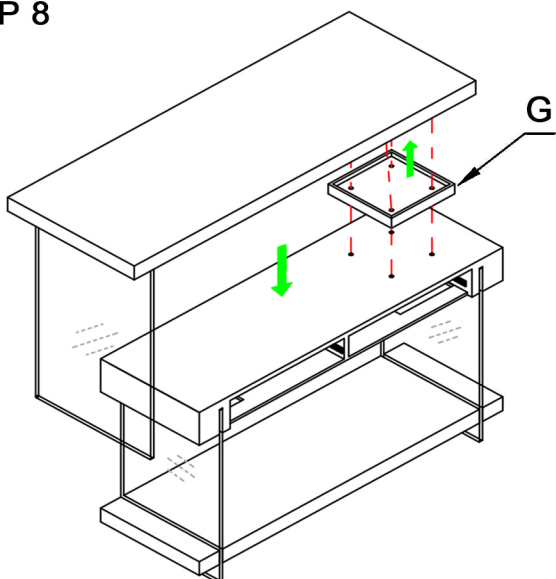

STEP 9

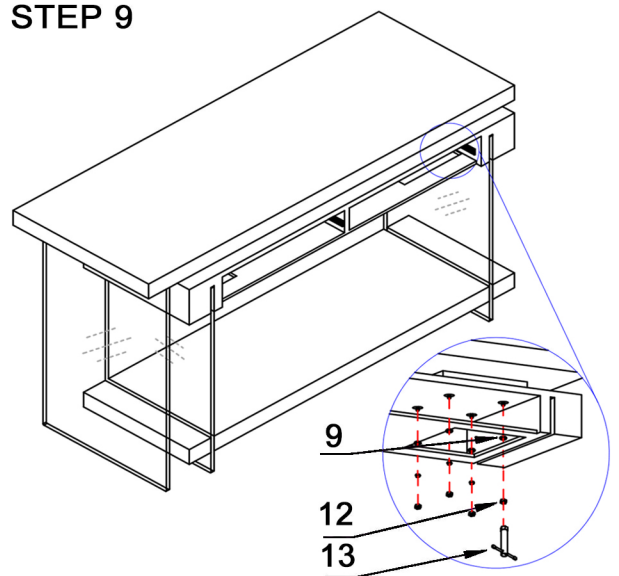



STEP 10

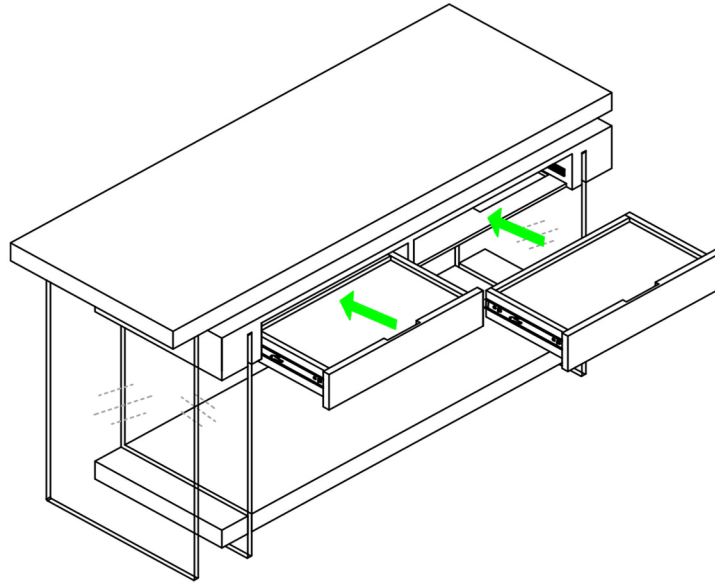

Finish

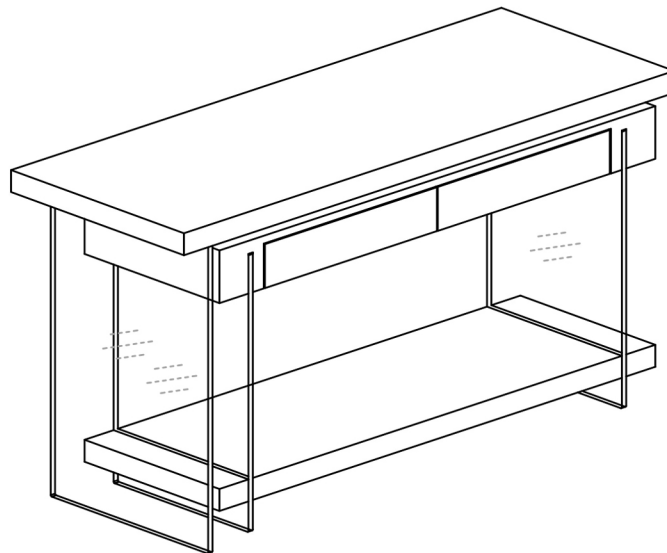

Finish

