



THANK YOU FOR PURCHASING THIS QUALITY PRODUCT.

BE SURE TO CHECK ALL PACKING MATERIAL CAREFULLY FOR SMALL PARTS THAT MAY HAVE COME LOOSE INSIDE THE CARTON DURING TRANSIT.

Step 1

Assemble wheels(F) to the base(D).

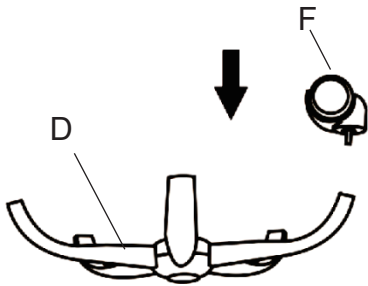

Step 2

Insert the gaslift to the base.

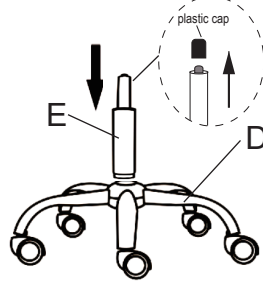

PART LIST

NO	DESC	SIZE(MM)	SKETCH	QTY
A	BACK	440x465		1
B	SEAT	450x470		1
C	TRAY	150x185		1
D	BASE	dia 300		1
E	GASLIFT	140		1
F	WHEEL	dia 50		5

Step 3

Assemble the tray(C) to the seat (B). Please notice the direction.

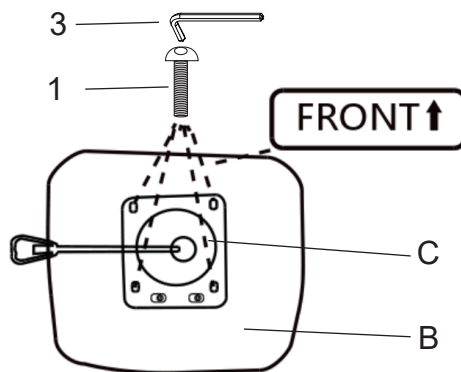

HARDWARE LIST

NO	DESC	SIZE(MM)	SKETCH	QTY
1	screw1	M6X20mm		4
2	screw2	M6X35mm		4
3	allen key	M6		1

Step 4

Assemble the backrest(A) to the seat(B).

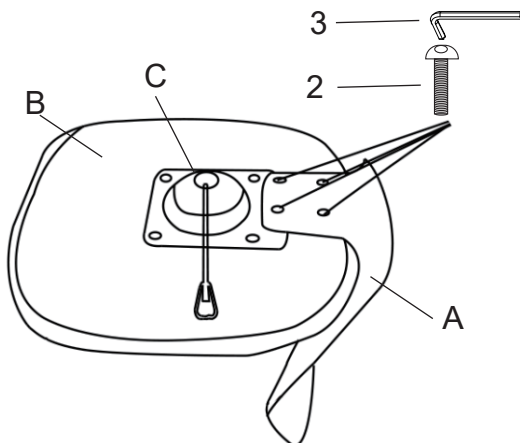

Step 5

Insert the gaslift into the whole where in the tray. Then finished.



FINISHED