

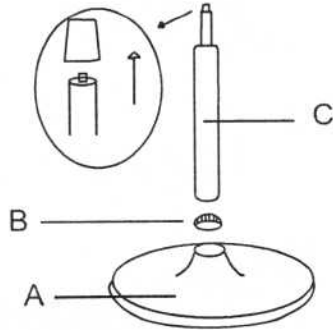

THANK YOU FOR PURCHASING THIS QUALITY PRODUCT.
BE SURE TO CHECK ALL PACKING MATERIAL CAREFULLY FOR SMALL PARTS THAT MAY HAVE COME LOOSE INSIDE THE CARTON DURING TRANSIT.

STEP 1



STEP 2

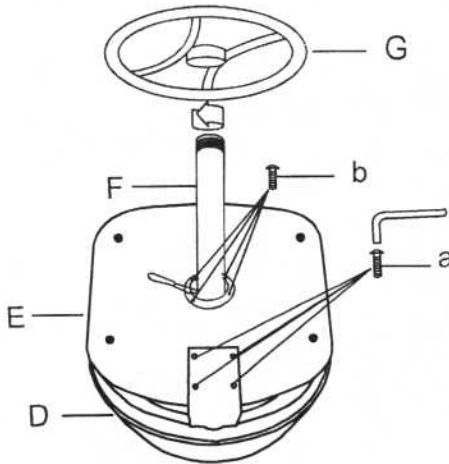

STEP 3



FINISH



PART LIST

	DESC	SIZE (MM)	SKETCH	QTY
A	BASE	DIA.450		1PC
B	COLLAR	DIA.75		1PC
C	GASLIFT	L.510		1PC
D	BACK			1PC
E	SEAT			1PC
F	OUTER TUBE	L.390		1PC
G	FOOTREST	DIA.370		1PC

HARDWARE LIST

NO	DESC	SIZE (MM)	SKETCH	QTY
a	SCREW	M6x20		4PCS
b	SCREW	M6x16		4PCS
g	SPANNER	M6		1PC