

# BUTLER

SPECIALTY COMPANY

8200 SOUTH CHICAGO AVE., CHICAGO, IL 60617

Assembly Instructions  
Style Number 3044

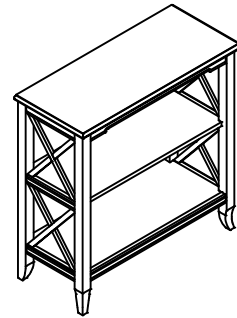

## PACKAGED

(A)	12-Bolt	$\phi 1/4" * 1-1/4"$
(B)	12-Lock Washer	$\phi 1/4"$
(C)	12-Flat Washer	$\phi 1/4" * \text{Dia} 19\text{mm}$
(D)	1-Allen Wrench	$\phi 1/4"$
(E)	28- screw	$6 * 3 * 15\text{mm}$
(F)	Top shelf	1pc
(G)	Middle shelf	1pc
(H)	Bottom shelf	1pc
(I)	Side frame	2pcs
(J)	Back Panel	2pcs

Read all instructions before starting assembly.

Step#1 Check all the components listed in the packaged are included.

Carefully lay Top Shelf (F) upside down on a flat and protected work surface being careful not to scratch the finish.

Step#2 Attach the Middle Shelf (G) to the Side Frame (I) with Bolt (A), Lock Washer (B), Flat Washer (C) and Allen Wrench (D). Repeat procedure for the other Side Frame (I) and leave the Bolts (A) loosely tighten.

Step#3 Attach the Bottom Shelf (H) to the Side Frame (I) with Bolt (A), Lock Washer (B), Flat Washer (C) and Allen Wrench (D). Repeat procedure for the other Side Frame (I) and leave the Bolts (A) loosely tighten.

Step#4 Attach the assembled Side Frames (I) with shelf to the wood cleat at the side of Top Shelf (F) with Bolt (A), Lock Washer (B), Flat Washer (C) and Allen Wrench (D) and leave the Bolts (A) loosely tighten.

Step#5 Assemble the Back Panels (J) by using Screws (E) and screwdriver. Then attach them to the back of product with Screws (E) and loosely tighten.

Step#6 Tighten all the Bolts and Screws securely.

Step#7 Turn the assembled unit over.

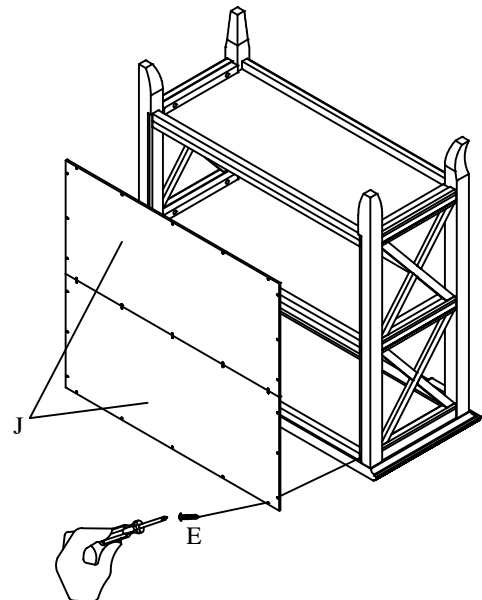
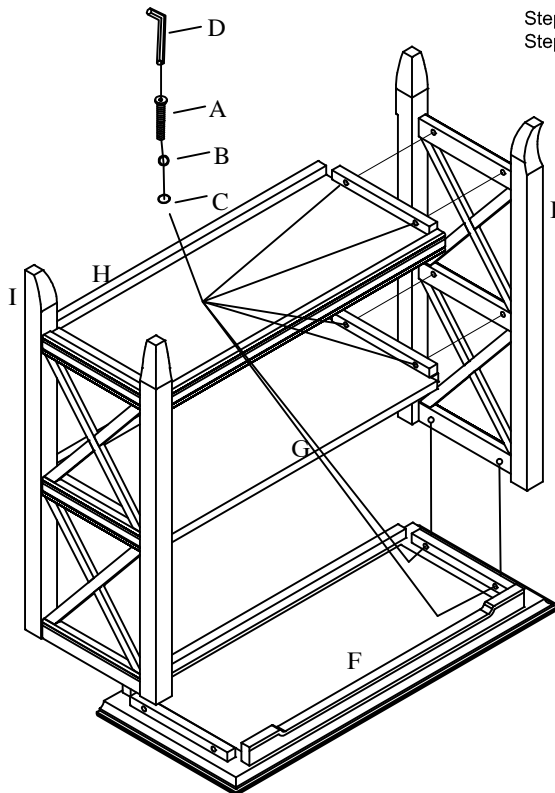

(\*). **Caution: DO NOT OVERTIGHTEN.**

In any correspondence regarding this product, please include the complete Butler identification number located on the underside of the product.

*We hope this bookcase will be a useful and decorative addition to your home for years to come.*

Copyright © Butler Specialty Company, 06/11