

BUTLER

SPECIALTY COMPANY

8200 SOUTH CHICAGO AVE., CHICAGO, IL 60617

Assembly Instructions Style Number 2225

PACKAGED

- | | |
|--|--------------------|
| (A) 9-Bolt $\frac{1}{4}$ "*1"L | (D) 1- Top |
| (B) 9-Lock Washer $\frac{1}{4}$ " | (E) 1-Bridge |
| (C) 9-Flat Washer $\frac{1}{4}$ "*16mm | (F) 1- Center Post |
| | (G) 1- Base |

Read all instructions before starting assembly.

Step #1 Remove all the contents from the package checking that all of the components listed in "Packaged" are included. Prepare a flat, protected work surface where the product can be assembled.

Step #2 Place the Bridge (E) assembly upside down and attach over to bottom of Top (D) with Bolt (A), Lock Washer (B) and Flat Washer (C). Repeat procedure for remaining holes and finally tighten all the Bolts (A).

Step #3 Position Center Post (F) upside down with large turning facing up. Align Base (G) over matching holes in bottom of Center Post (F), assemble with Bolt (A), Lock Washer (B) and Flat Washer (C). Repeat procedure for remaining Bolts (A), Lock Washer (B) and Flat Washer (C) and finally securely tighten.

Step #4 Place Center Post (F) and Base (G) assembly into upright position. Assemble Bridge (E) to the small diameter top of Center Post (F) with Bolt (A), Lock Washer (B) and Flat Washer (C).

Step #5 Place assembled Table into upright position.

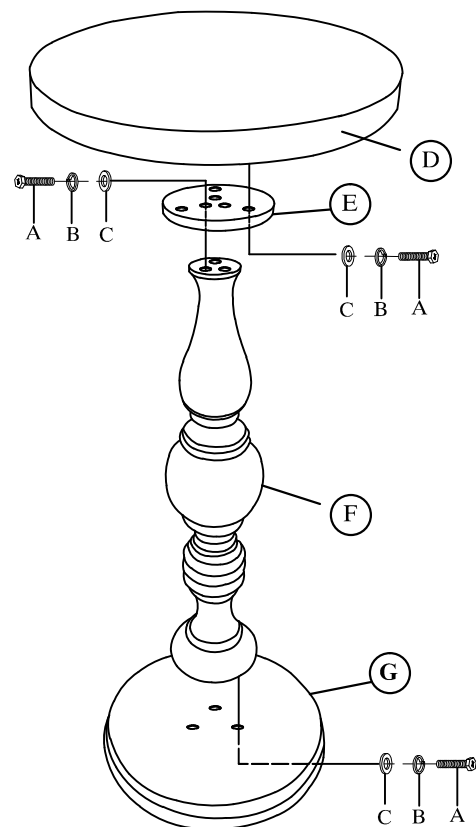
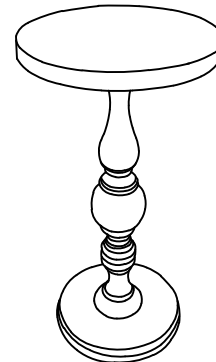

(* Caution: DO NOT OVERTIGHTEN

In any correspondence regarding this product, please include the complete Butler identification number located on the underside of the product.

We hope this Accent Table will be a useful and decorative addition to your home for years to come.

Copyright © Butler Specialty Company, 10/15