

BUTLER

SPECIALTY COMPANY

8200 SOUTH CHICAGO AVE., CHICAGO, IL 60617

Assembly Instructions
Style Number 2126

PACKAGED

- (A) 8- Bolt □ 5/16"*1-3/4"
- (B) 8-Lock Washer □ 5/16"
- (C) 8-Flat Washer □ 5/16"*Dia16mm
- (D) 1set- Anti-tipping kit.

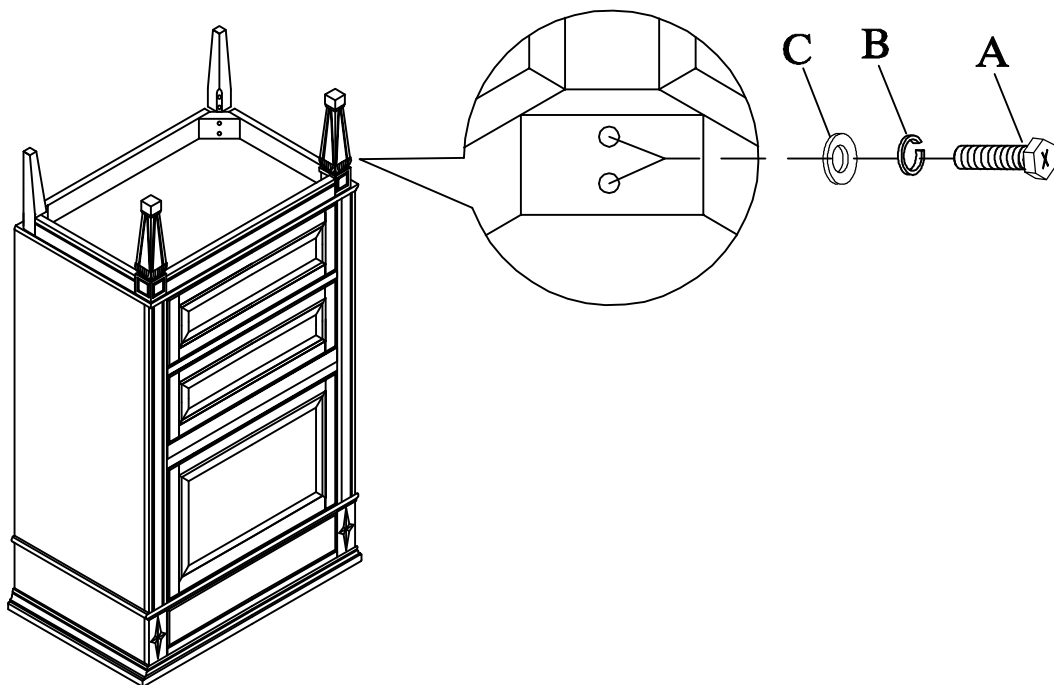
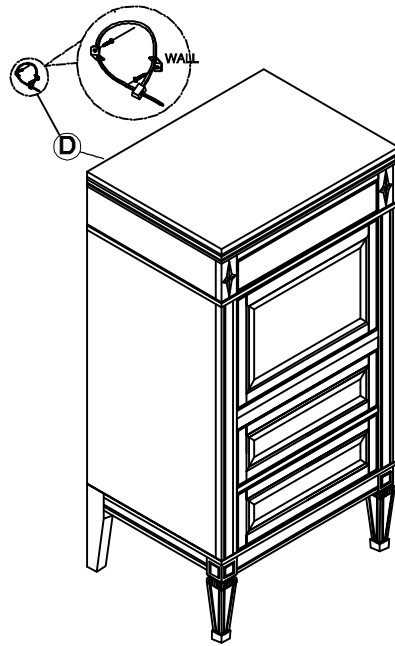

(*Caution:DO NOT OVERTIGHTEN

In any correspondence regarding this product, please include the complete Butler identification number located on the underside of the product.

We this Secretary be a useful and decorative addition to your home for years to come.

Copyright © Butler Specialty Company, 07/10