

# BUTLER

Assembly Instructions  
Style Number 1589

SPECIALTY COMPANY  
8200 SOUTH CHICAGO AVE., CHICAGO, IL 60617

## PACKAGED

- |  |                  |
|--|------------------|
| (A) 8 -Bolts $\text{\O}1/4'' \times 1-1/2''$ | (D) 1 -Table Top |
| (B) 8 -Spring washer                         | (E) 4 -Legs      |
| (C) 8 -Flat washer                           |                  |

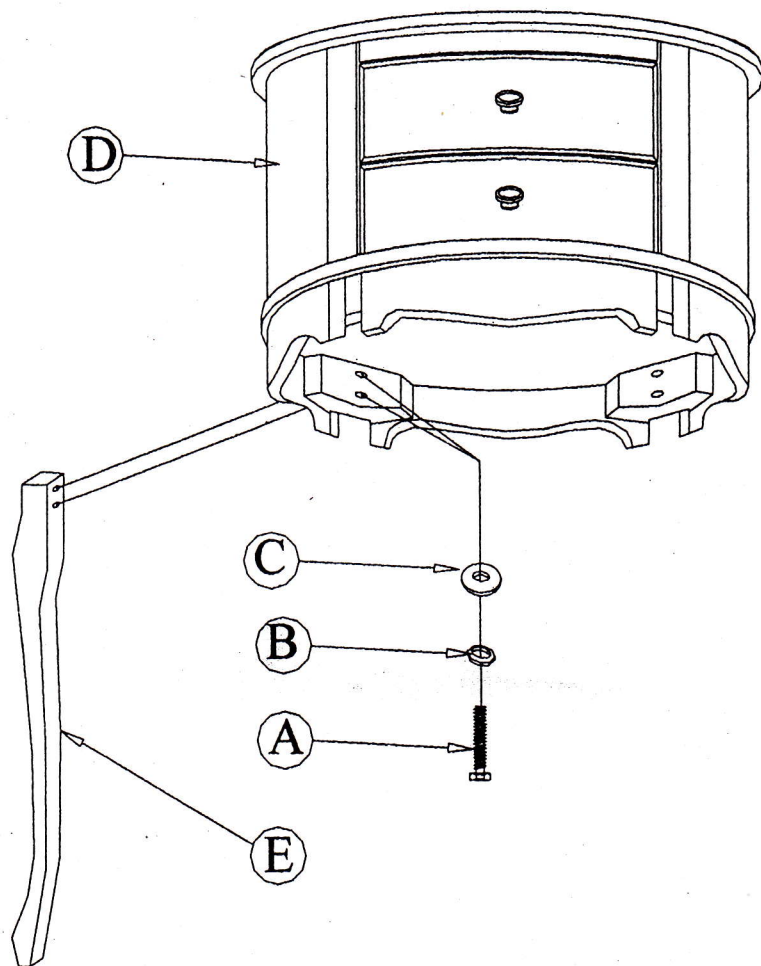

(\* Caution: DO NOT OVERTIGHTEN.

For any correspondence regarding this product, please include the complete Butler identification number located on the underside of the product.

*We hope this Commode will be a useful and decorative addition to your home for years to come.*

Copyright © Butler Specialty Company, 10/07