

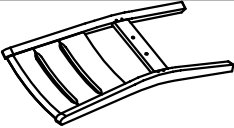

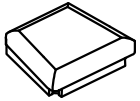



ASSEMBLY INSTRUCTIONS

MODEL#: 8540-510 DORVAL CHAIR V#12600PHMA

**NOTE: THIS ITEM NOT RECOMMENDED FOR COMMERCIAL USE
KEEP THIS DOCUMENT FOR REFERENCE IN CASE PARTS ARE NEEDED
DO NOT TIGHTEN SCREWS UNTIL COMPLETELY ASSEMBLED! !**

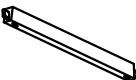
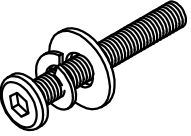
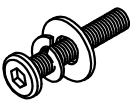
NO		PARTS LIST	Q'TY
A		CHAIR BACK	1 PC
B		CHAIR SEAT	1 PC
C		LEG LEFT	1 PC
D		LEG RIGHT	1 PC
E		STRETCHER LEFT	1 PC
F		STRETCHER RIGHT	1 PC

NO		HARDWARE LIST	Q'TY	
1		Long Bolt	Ø5/16"x2-3/4"	8 PCS
		Lock Washer	Ø5/16"	8 PCS
		Flat Washer	Ø5/16"x19Dx1.5mm	8 PCS
2		Short Bolt	Ø1/4"x1-1/2"	2 PCS
		Lock Washer	Ø1/4"	2 PCS
		Flat Washer	Ø1/4"x19Dx2mm	2 PCS
3		Screws	#8x1-3/4"	4 PCS
4		Allen Wrench	3"x4mm	1 PC

ASSEMBLY INSTRUCTIONS

MODEL#: 8540-510 DORVAL CHAIR V#12600PHMA

**NOTE: THIS ITEM NOT RECOMMENDED FOR COMMERCIAL USE
KEEP THIS DOCUMENT FOR REFERENCE IN CASE PARTS ARE NEEDED
DO NOT TIGHTEN SCREWS UNTIL COMPLETELY ASSEMBLED! !**

STEP 1

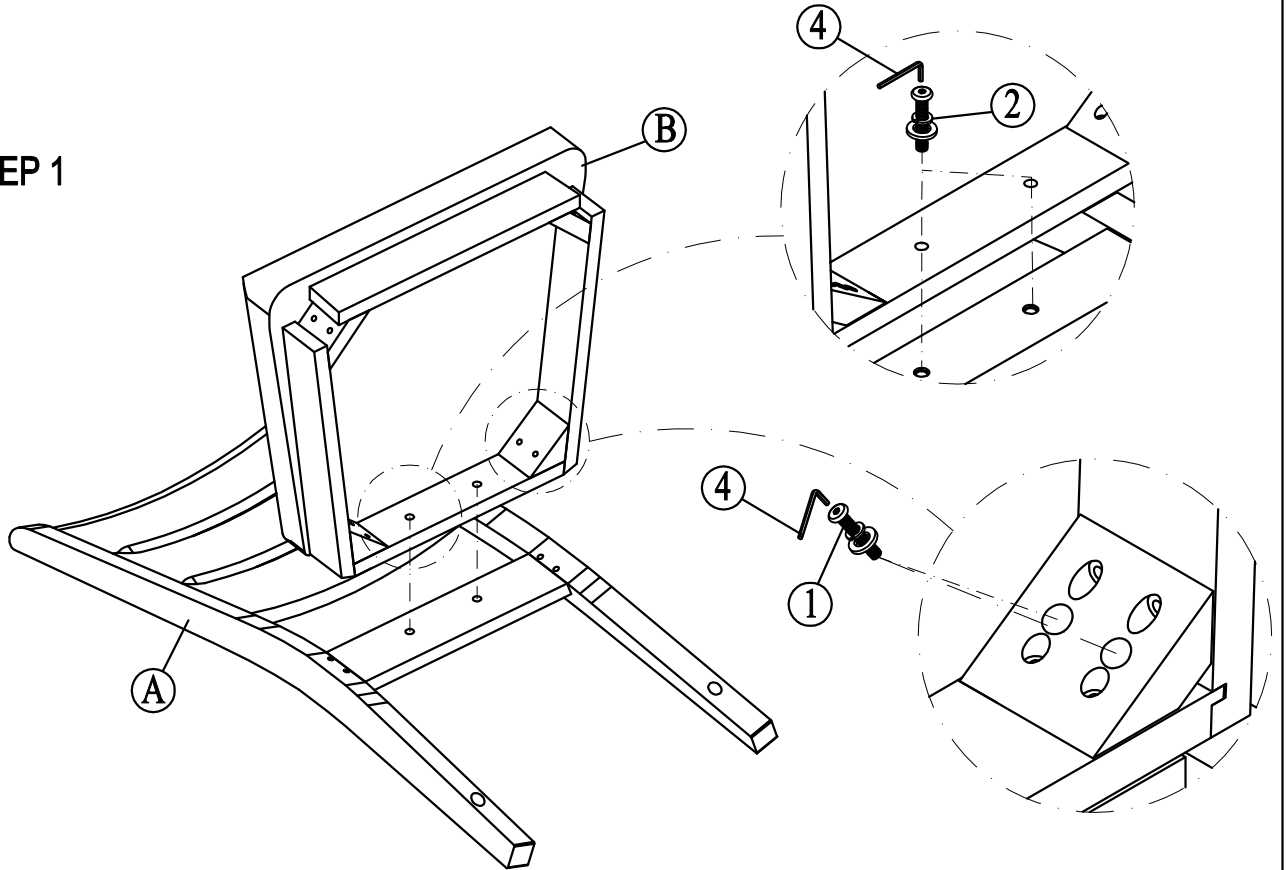

STEP 2

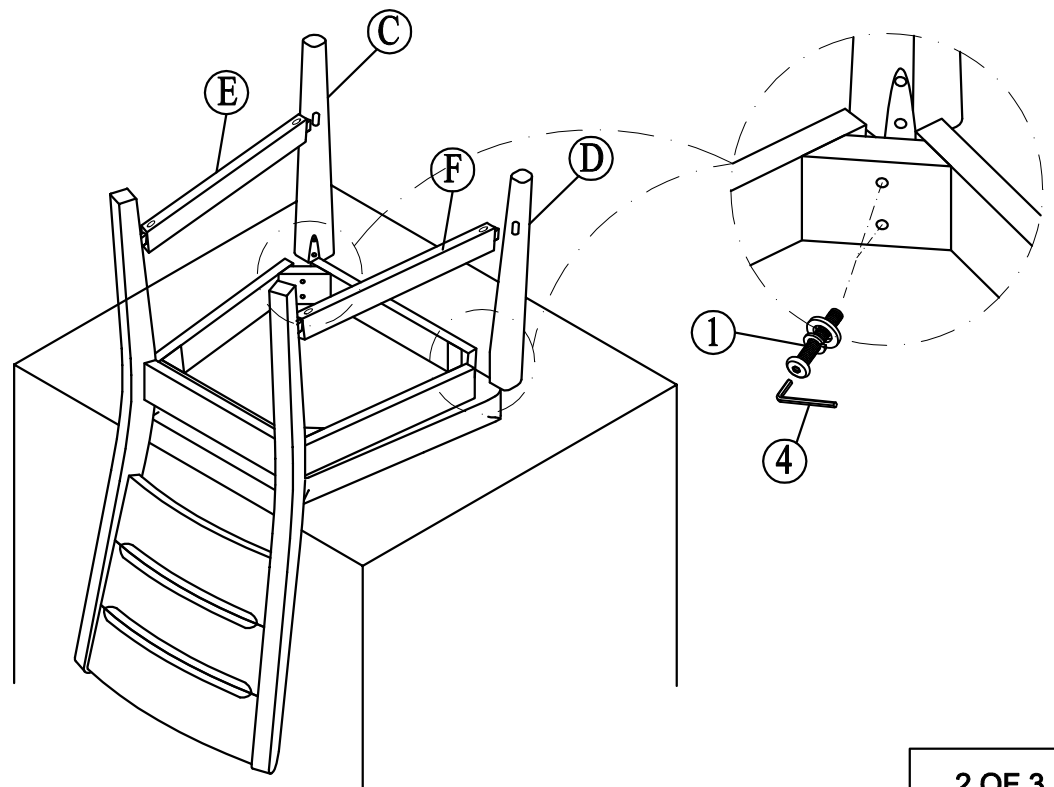

ASSEMBLY INSTRUCTIONS

MODEL#: 8540-510 DORVAL CHAIR V#12600PHMA

**NOTE: THIS ITEM NOT RECOMMENDED FOR COMMERCIAL USE
KEEP THIS DOCUMENT FOR REFERENCE IN CASE PARTS ARE NEEDED
DO NOT TIGHTEN SCREWS UNTIL COMPLETELY ASSEMBLED! !**

STEP 3

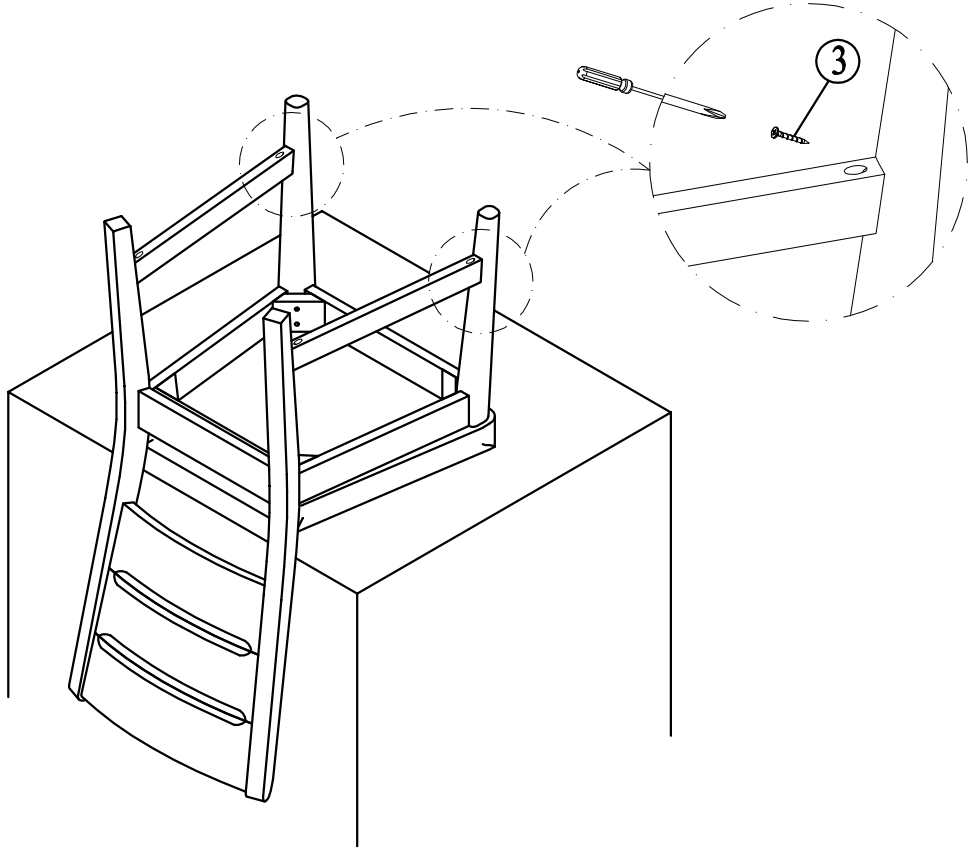

Assembly Completed

