







ASSEMBLY INSTRUCTIONS

MODEL#: 8540-500 DORVAL TABLE V#12600PHMA

**NOTE: THIS ITEM NOT RECOMMENDED FOR COMMERCIAL USE
KEEP THIS DOCUMENT FOR REFERENCE IN CASE PARTS ARE NEEDED
DO NOT TIGHTEN SCREWS UNTIL COMPLETELY ASSEMBLED! !**

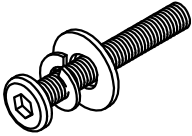
NO	PARTS LIST		Q'TY
A		TOP TABLE	1 PC
B		SUPPORT	1 PC
C		SUPPORT	1 PC
D		LEGS	4 PCS

NO	HARDWARE LIST		Q'TY	
1		Long Bolt	Ø5/16"x2-3/4"	8 PCS
		Lock Washer	Ø5/16"	8 PCS
		Flat Washer	Ø5/16"x19Dx1.5mm	8 PCS
2		Screws	#8x1-3/4"	5 PCS
3		Allen Wrench	3"x4mm	1 PC

ASSEMBLY INSTRUCTIONS

MODEL#: 8540-500 DORVAL TABLE V#12600PHMA

**NOTE: THIS ITEM NOT RECOMMENDED FOR COMMERCIAL USE
KEEP THIS DOCUMENT FOR REFERENCE IN CASE PARTS ARE NEEDED
DO NOT TIGHTEN SCREWS UNTIL COMPLETELY ASSEMBLED! !**

STEP 1

Do not tighten
the screw

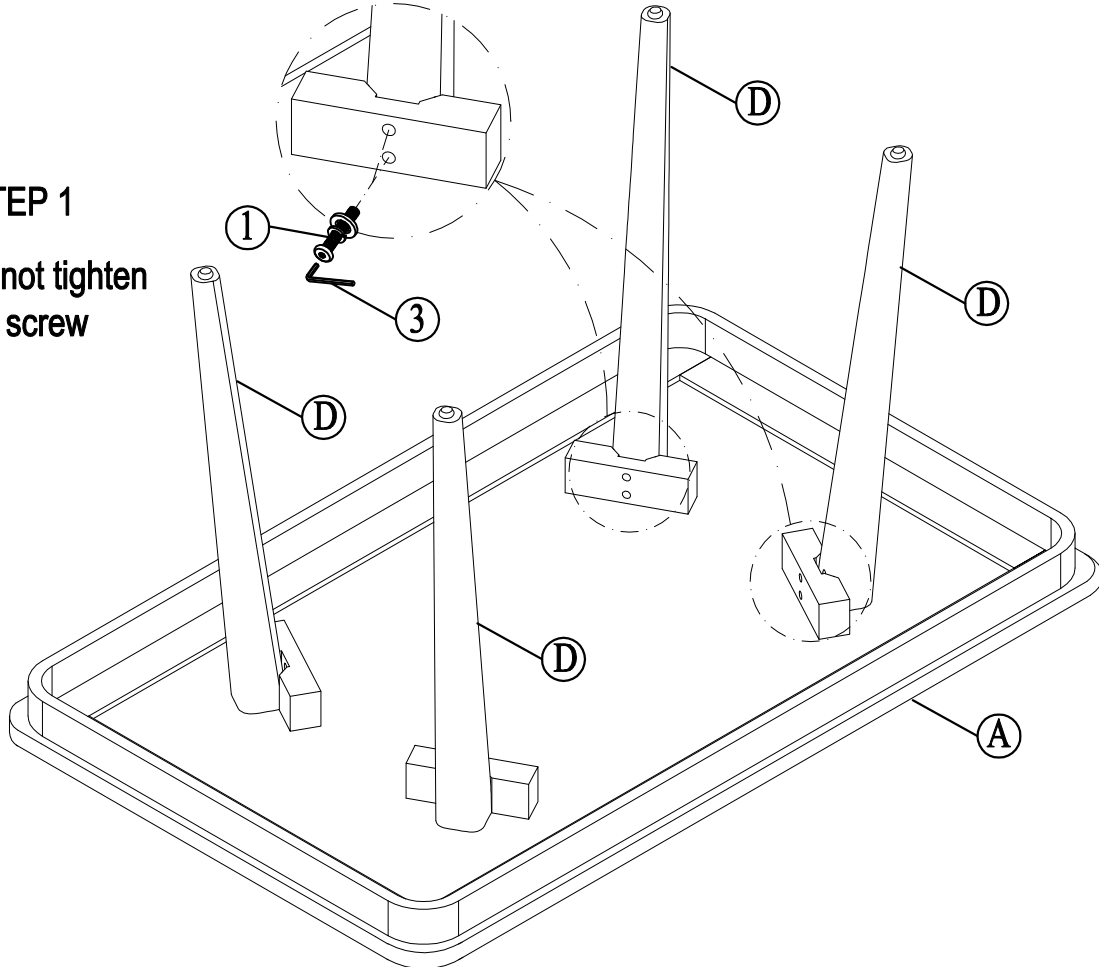

STEP 2

Insert the cross bar when the
screw is not tightened

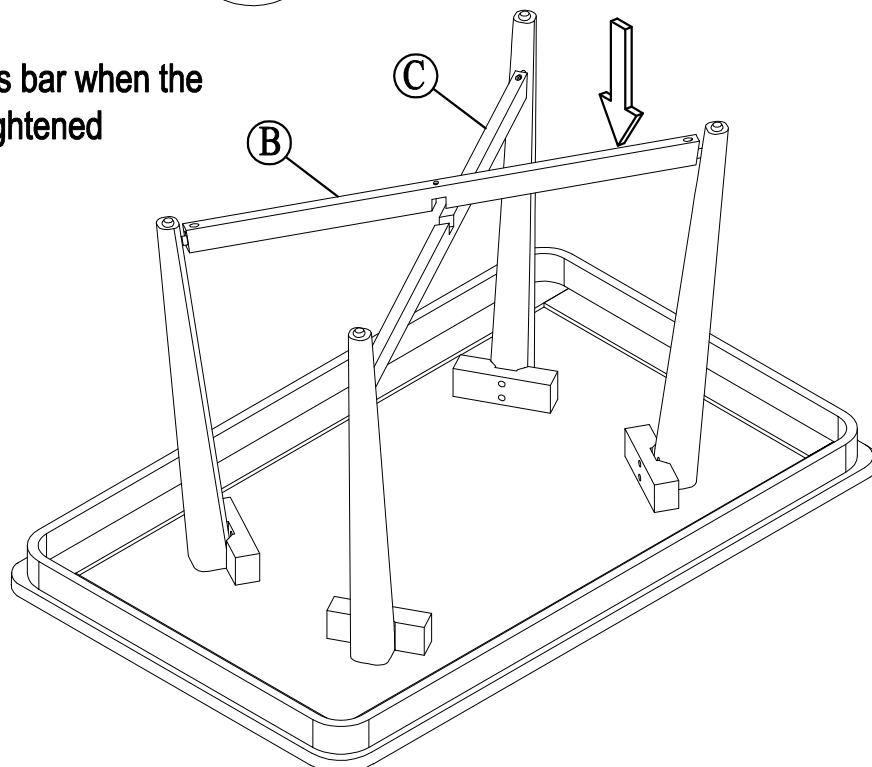

ASSEMBLY INSTRUCTIONS

MODEL#: 8540-500 DORVAL TABLE V#12600PHMA

**NOTE: THIS ITEM NOT RECOMMENDED FOR COMMERCIAL USE
KEEP THIS DOCUMENT FOR REFERENCE IN CASE PARTS ARE NEEDED
DO NOT TIGHTEN SCREWS UNTIL COMPLETELY ASSEMBLED! !**

STEP 3

Lock the quick tooth
only after tightening the
screw rod

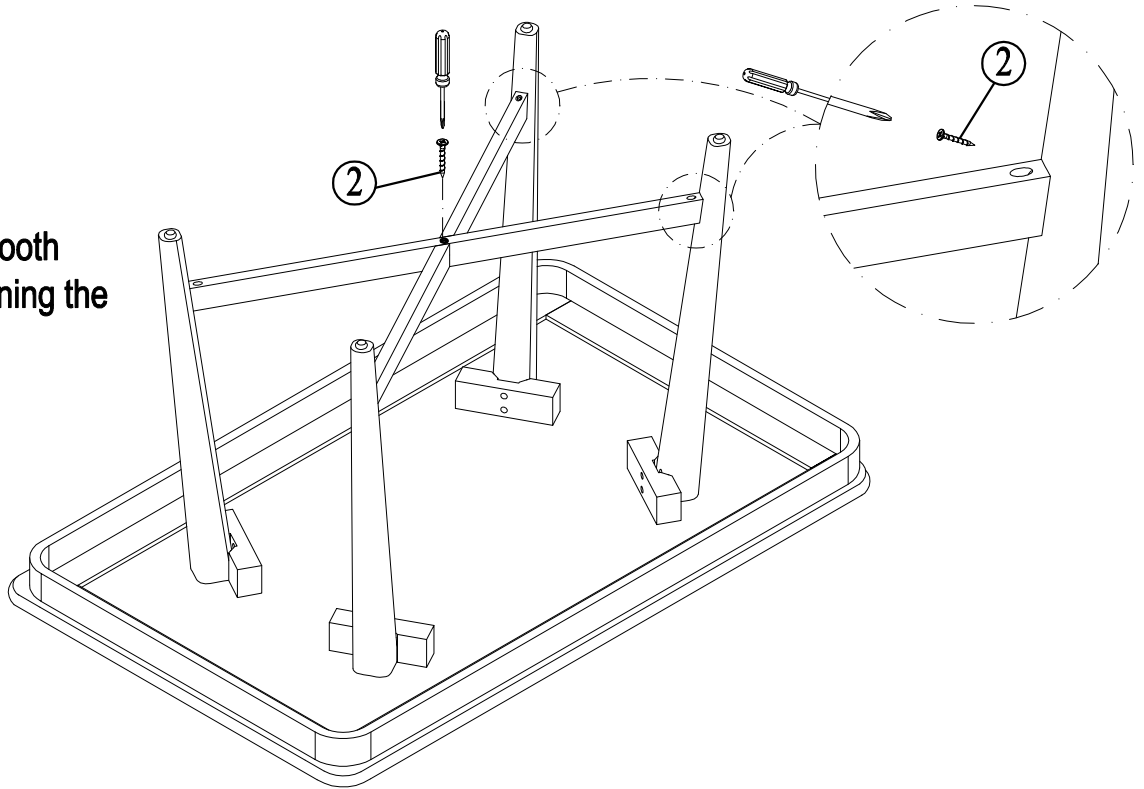

Assembly Completed

