





## ASSEMBLY INSTRUCTION

MODEL : #5938-532, #5938DS-533, #5938-540 Stool ( V#12600CSES1)

**NOTE : THIS ITEM NOT RECOMMENDED FOR COMMERCIAL USE  
KEEP THIS DOCUMENT FOR REFERENCE IN CASE PARTS ARE NEEDED  
DO NOT TIGHTEN SCREWS UNTIL COMPLETELY ASSEMBLED**

HARDWARE LIST			
NO		DESCRIPTION	QTY
1		JCBC BOLT M6 x 50MM	8 PCS
2		SPRING WASHER M6	8 PCS
3		FLAT WASHER M6	8 PCS
4		CSK Screw M4 x 38MM	8 PCS
5		Allen Key M4 x 110MM	1 PC

PART LIST			
NO		DESCRIPTION	QTY
A		SEAT	1
B		LEG (R/L)	4
C		STRETCHER - LONG	2
D		STRETCHER - SHORT	2

# ASSEMBLY INSTRUCTION

MODEL : #5938-532, #5938DS-533, #5938-540 Stool ( V#12600CSES1)

Step 1  
Do not over tighten the hardware.

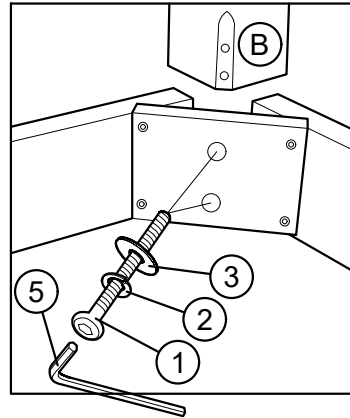
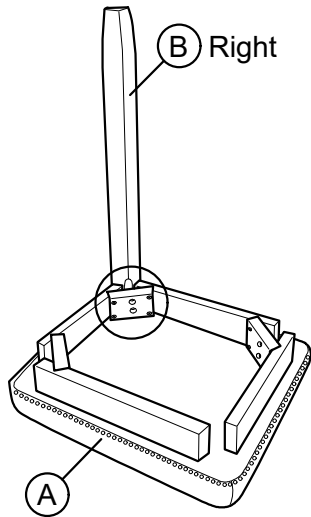

Step 2  
Do not over tighten the hardware.

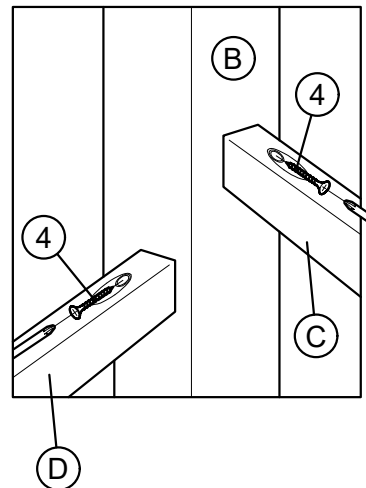
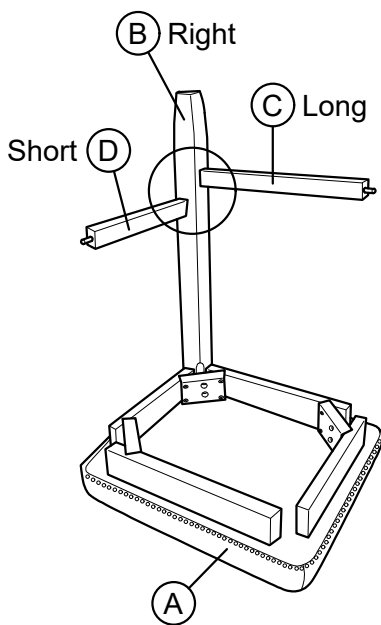

# ASSEMBLY INSTRUCTION

MODEL : #5938-532, #5938DS-533, #5938-540 Stool ( V#12600CSES1)

Step 3  
Do not over tighten the hardware.

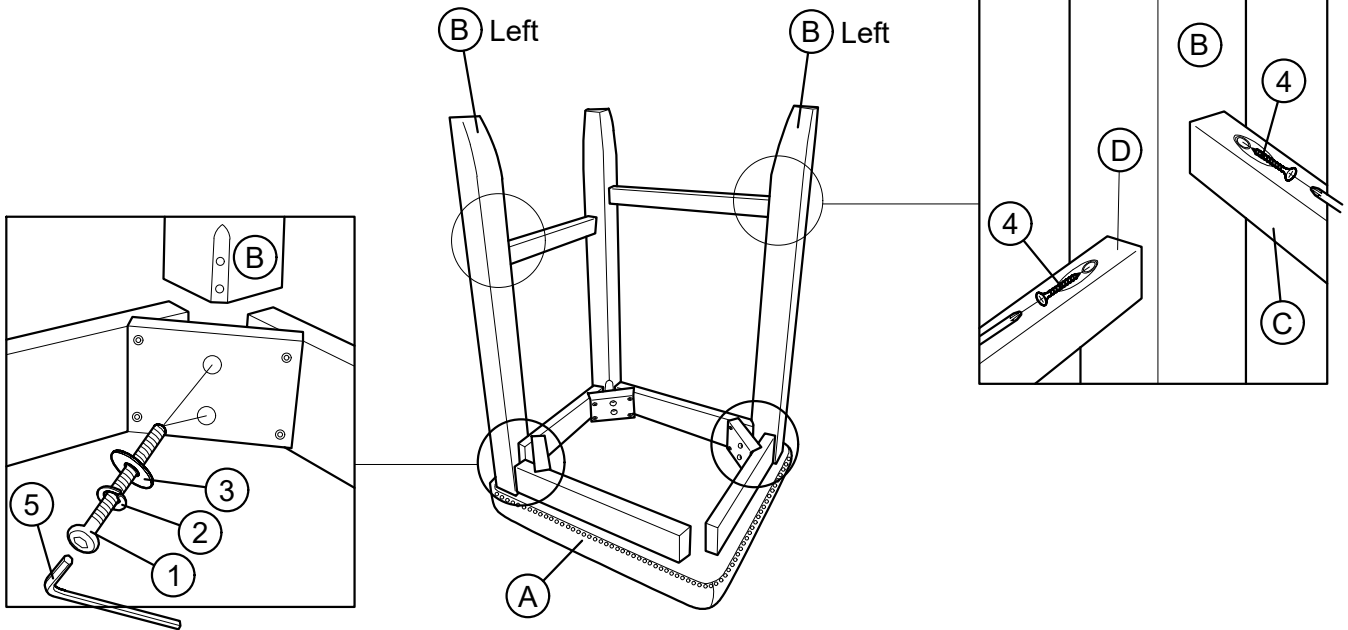

Step 4  
Do not over tighten the hardware.

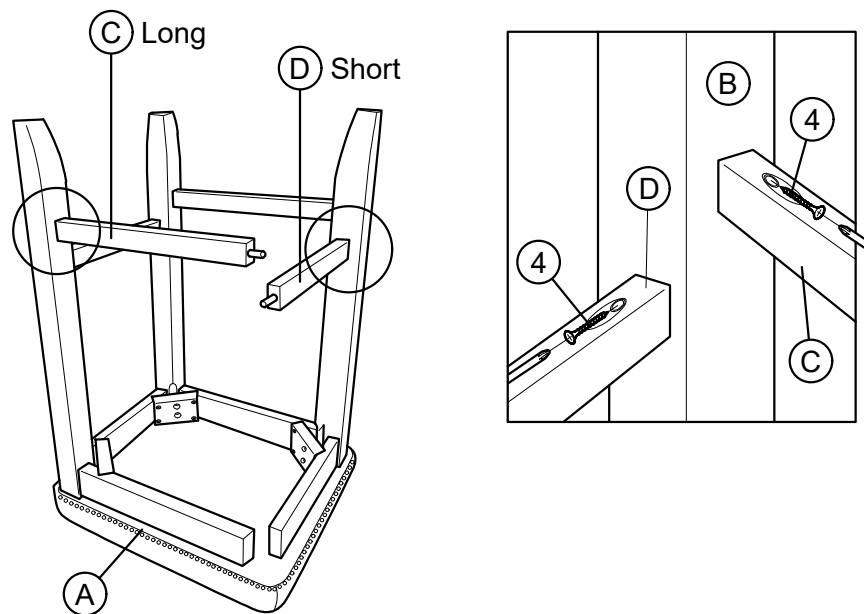

# ASSEMBLY INSTRUCTION

MODEL : #5938-532, #5938DS-533, #5938-540 Stool ( V#12600CSES1)

Step 5  
Tighten all hardware in this step.

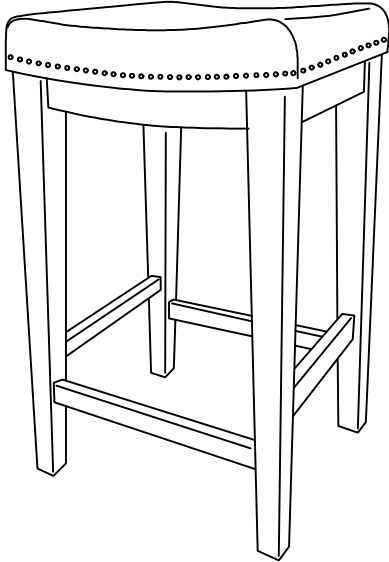
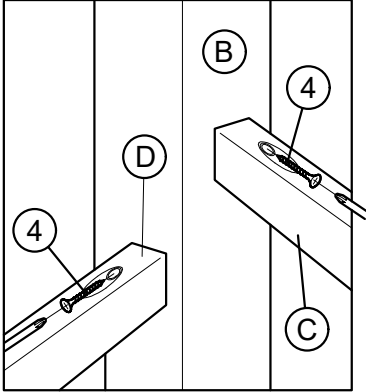
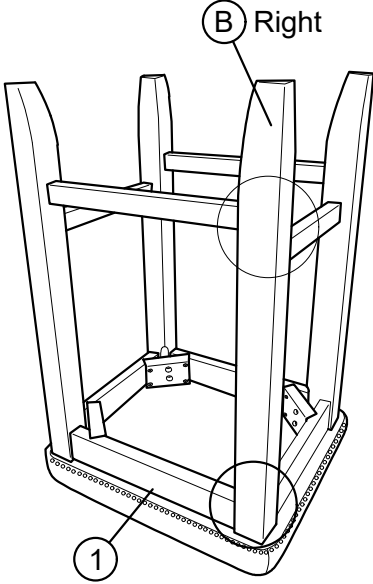
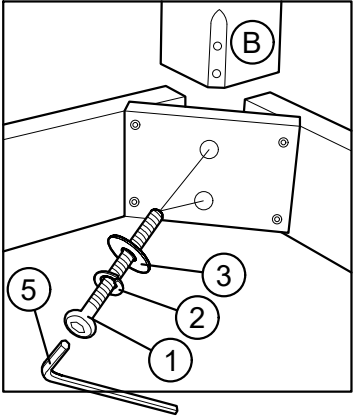

ASSEMBLY COMPLETED