













ASSEMBLY INSTRUCTION

MODEL: #5800-540 Summerville II Counter Stool (V#12600CSES1)

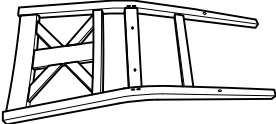
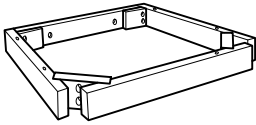
**NOTE: THIS ITEM NOT RECOMMENDED FOR COMMERCIAL USE
KEEP THIS DOCUMENT FOR REFERENCE IN CASE PARTS ARE NEEDED
DO NOT TIGHTEN SCREWS UNTIL COMPLETELY ASSEMBLED**

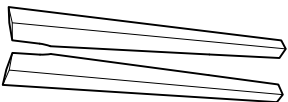
HARDWARE LIST			
NO	ITEM	DESCRIPTION	QTY
1		JCBC BOLT M6 x 70MM	4 PCS
2		JCBC BOLT M6 x 60MM	4 PCS
3		JCBC BOLT M6 x 35MM	2 PCS
4		SPRING WASHER M6	1 PC
5		FLAT WASHER M6 x 13MM	2 PCS
6		FLAT WASHER M6 x 16MM	2 PCS
7		CSK SCREW M4 x 38MM	2 PCS
8		ALLEN KEY M4 x 110MM	2 PCS

PART LIST			
NO	ITEM	DESCRIPTION	QTY
A		BACKREST	1
B		BOX SEAT	1
C		SEAT	1
D		FRONT LEG R/L	2
E		SIDE STRETCHER R/L	2
F		FRONT STRETCHER	1

ASSEMBLY INSTRUCTION

MODEL: #5800-540 Summerville II Counter Stool (V#12600CSES1)

Step 1

Install item (B) to the item (A) as shown below.
Do not tighten the hardware in this step.

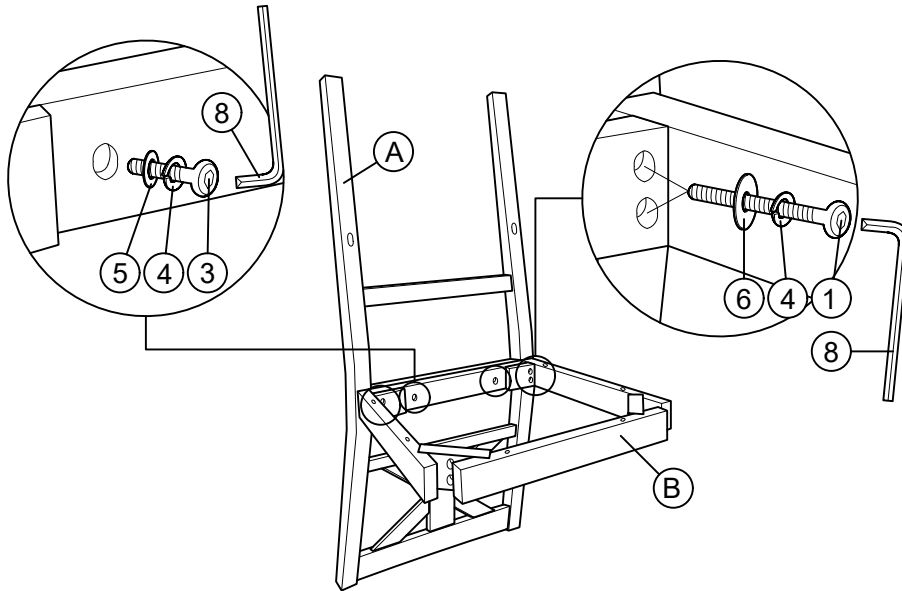

Step 2

Identified item (E) as shown below.

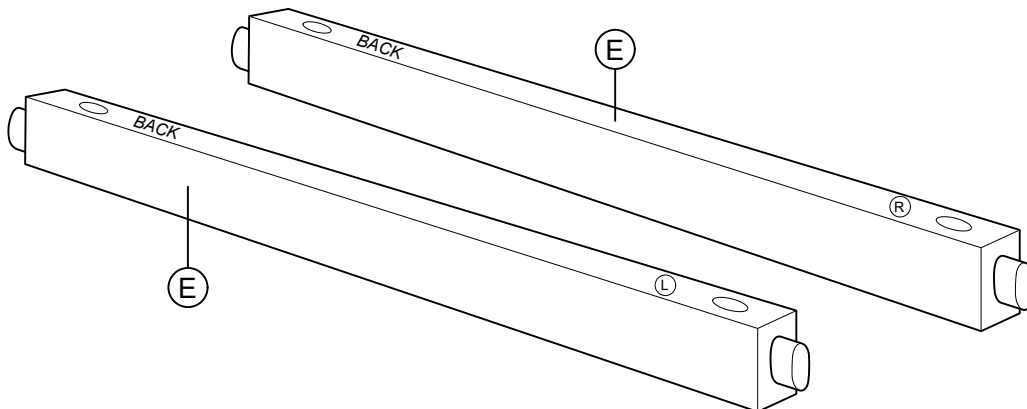

ASSEMBLY INSTRUCTION

MODEL: #5800-540 Summerville II Counter Stool (V#12600CSES1)

Step 3

Install item (E) to the item (A) as shown below.
Do not tighten the hardware in this step.

 Make sure to attach item (E) with **BACK** sticker to the item (A) as shown in the picture.

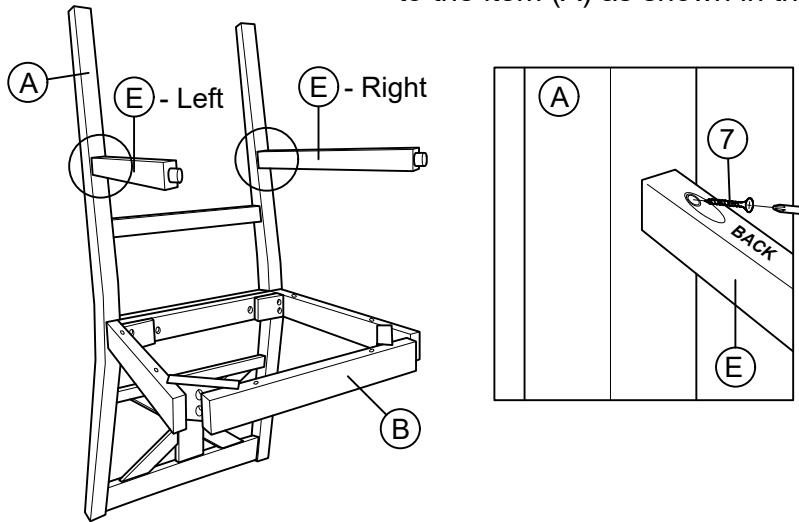

Step 4

Install item (F) to the item (D) and install it together with the item (B) and item (E).
Tighten all hardware in this step.

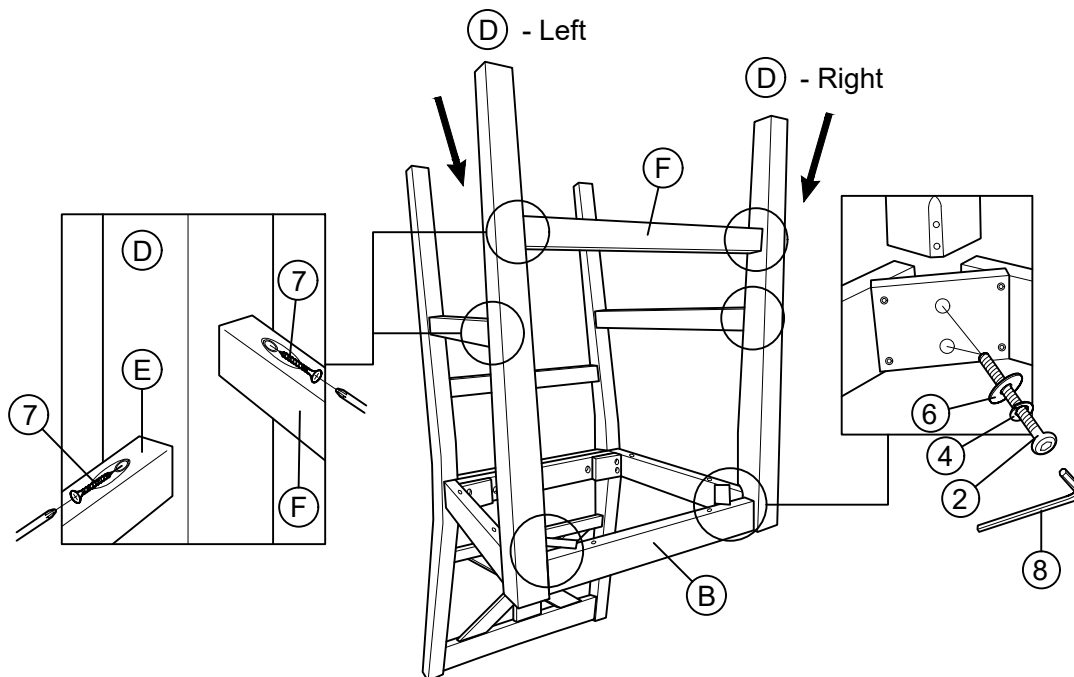

ASSEMBLY INSTRUCTION

MODEL: #5800-540 Summerville II Counter Stool (V#12600CSES1)

Step 5

Install previous assembling with Seat (C) as shown below.
Make sure to tighten all hardware.

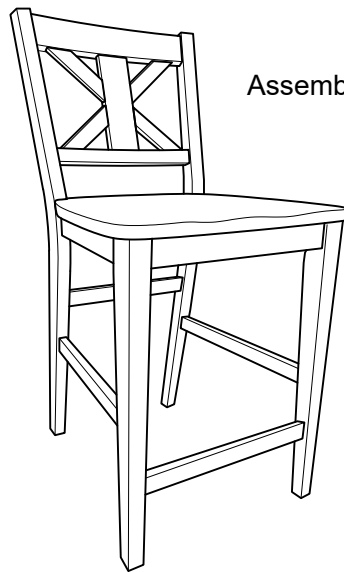
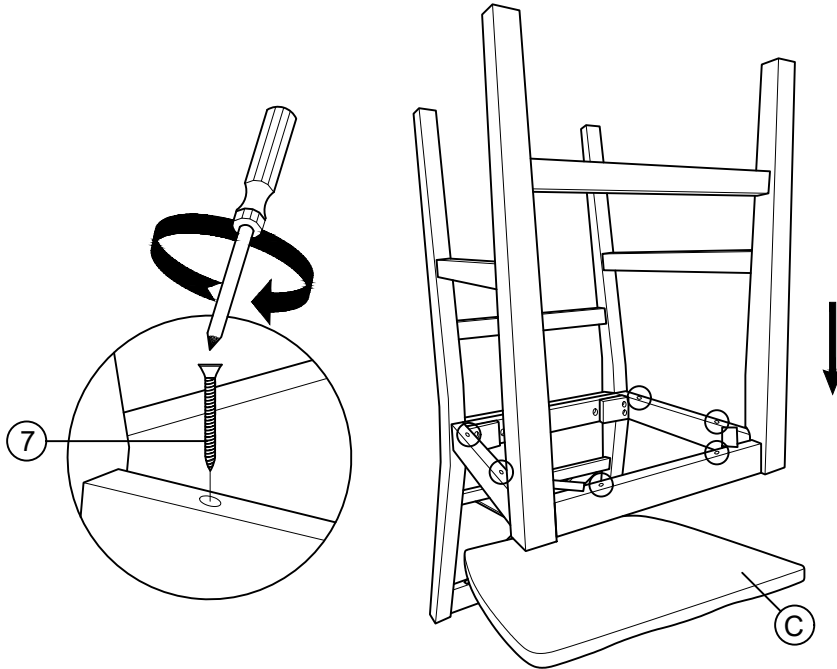

Assembly completed