





ASSEMBLY INSTRUCTIONS





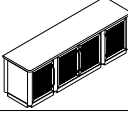
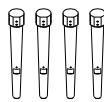

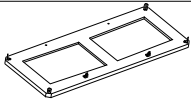

MODEL # : 338-524 SERVER CEMENT TOP W/CANE (V#12600HMY)

NOTE: KEEP THIS DOCUMENT FOR REFERENCE IN CASE PARTS ARE NEEDED

DO NOT TIGHTEN SCREWS UNTIL COMPLETELY ASSEMBLED!!

UNIT SHOULD BE ASSEMBLED BY TWO OR MORE PEOPLE.

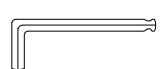
No	PART LIST		Q'TY
A		SIDE BOARD	1PC
B		LEGS-FRONT\BACK	4PCS
C		MIDDLE LEGS	2PCS
D		SHELF	1PC
E		SUPPORT LEGS	2PCS

No	HARDWARE LIST			Q'TY
1		FLAT WASHER	$\phi 5/16 \times 19 \times 1.5\text{mm}$	12PCS
2		LOCK WASHER	$\phi 5/16 \times 13 \times 1\text{mm}$	12PCS
3		ALLEN BOLT	$\phi 5/16 \times 2-1/2"$	12PCS
4		FLAT WASHER	$\phi 1/4 \times 19 \times 1.5\text{mm}$	6PCS
5		LOCK WASHER	$\phi 1/4 \times 13 \times 1\text{mm}$	6PCS
6		ALLEN BOLT	$\phi 1/4 \times 1"$	6PCS
7		ALLEN KEY	$2-3/8 \times 4\text{mm}$	1PC
8		Furniture Tipping Restraint (Not included screwdriver)		1SET

ASSEMBLY INSTRUCTIONS

MODEL # : 338-524 SERVER CEMENT TOP W/CANE (V#12600HMY)

NOTE: KEEP THIS DOCUMENT FOR REFERENCE IN CASE PARTS ARE NEEDED
DO NOT TIGHTEN SCREWS UNTIL COMPLETELY ASSEMBLED!!
UNIT SHOULD BE ASSEMBLED BY TWO OR MORE PEOPLE.

STEP 1

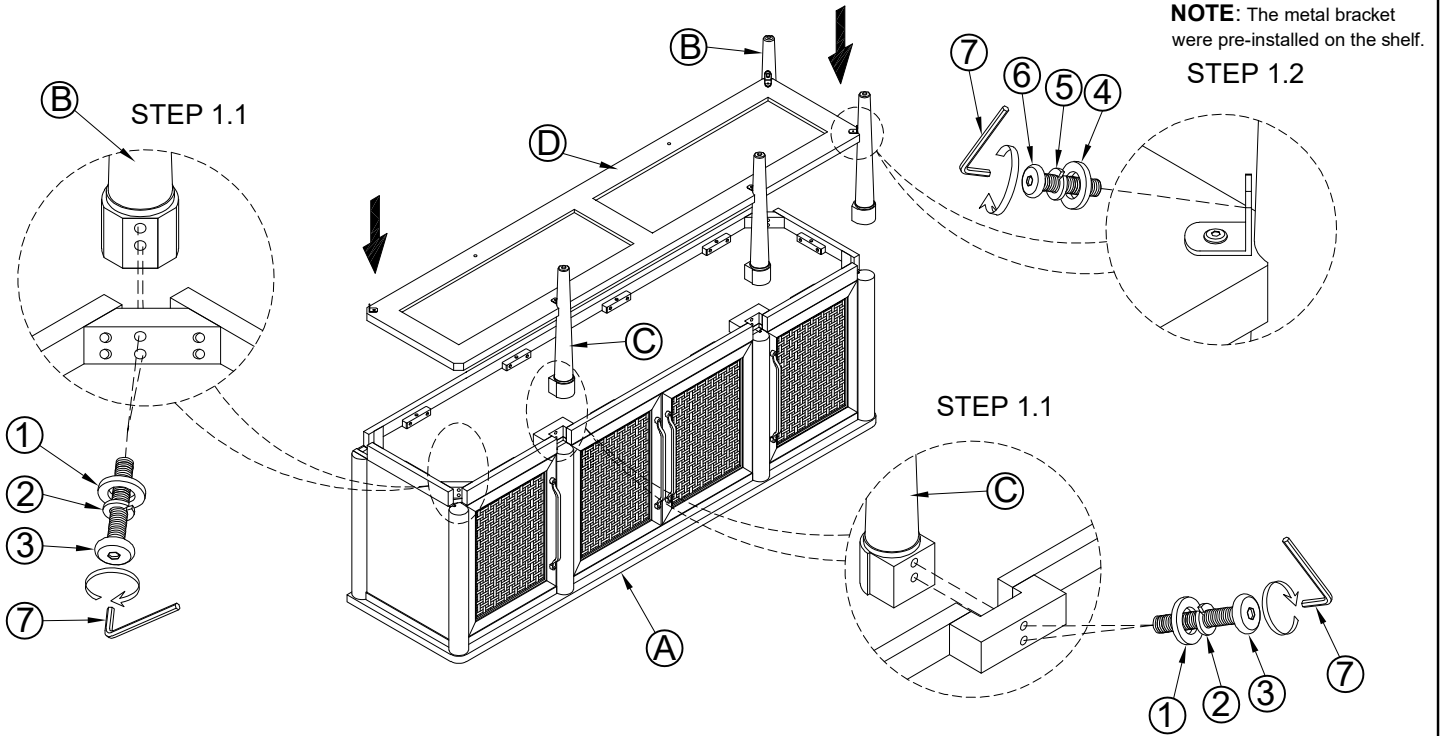

STEP 2

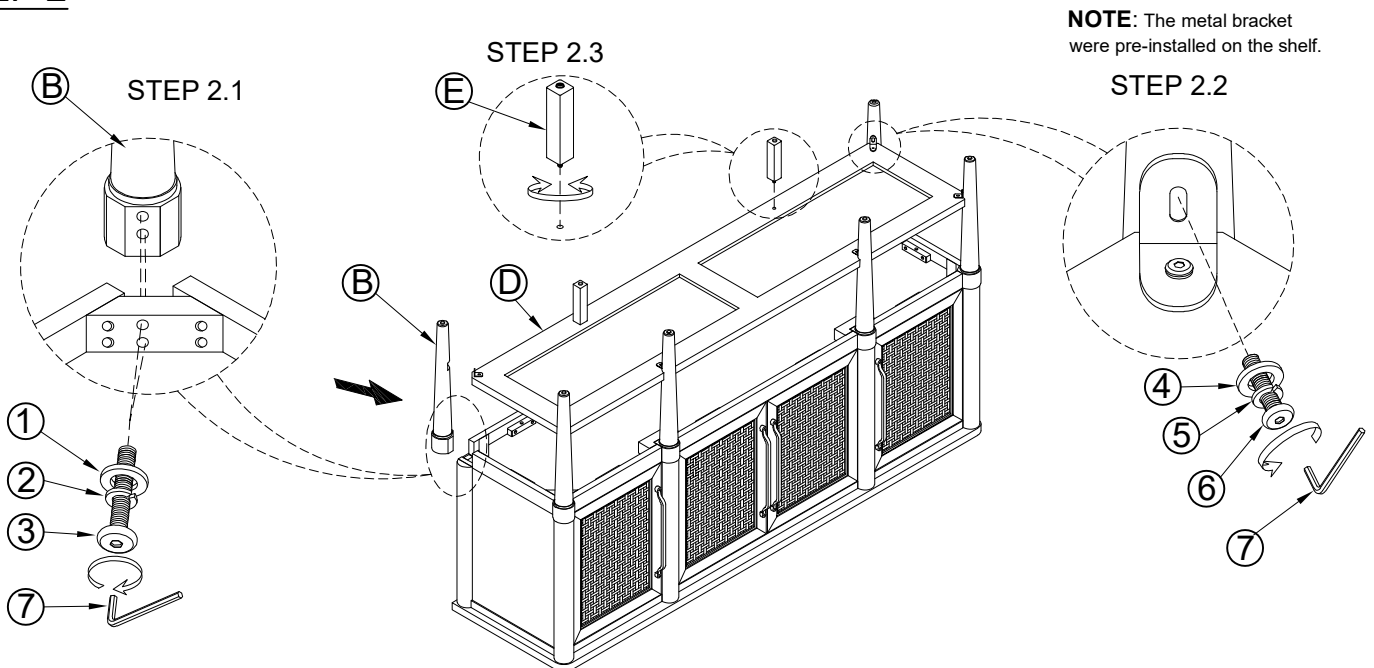

ASSEMBLY INSTRUCTIONS

MODEL # : 338-524 SERVER CEMENT TOP W/CANE (V#12600HMY)

NOTE: KEEP THIS DOCUMENT FOR REFERENCE IN CASE PARTS ARE NEEDED
DO NOT TIGHTEN SCREWS UNTIL COMPLETELY ASSEMBLED!!
UNIT SHOULD BE ASSEMBLED BY TWO OR MORE PEOPLE.

STEP 3

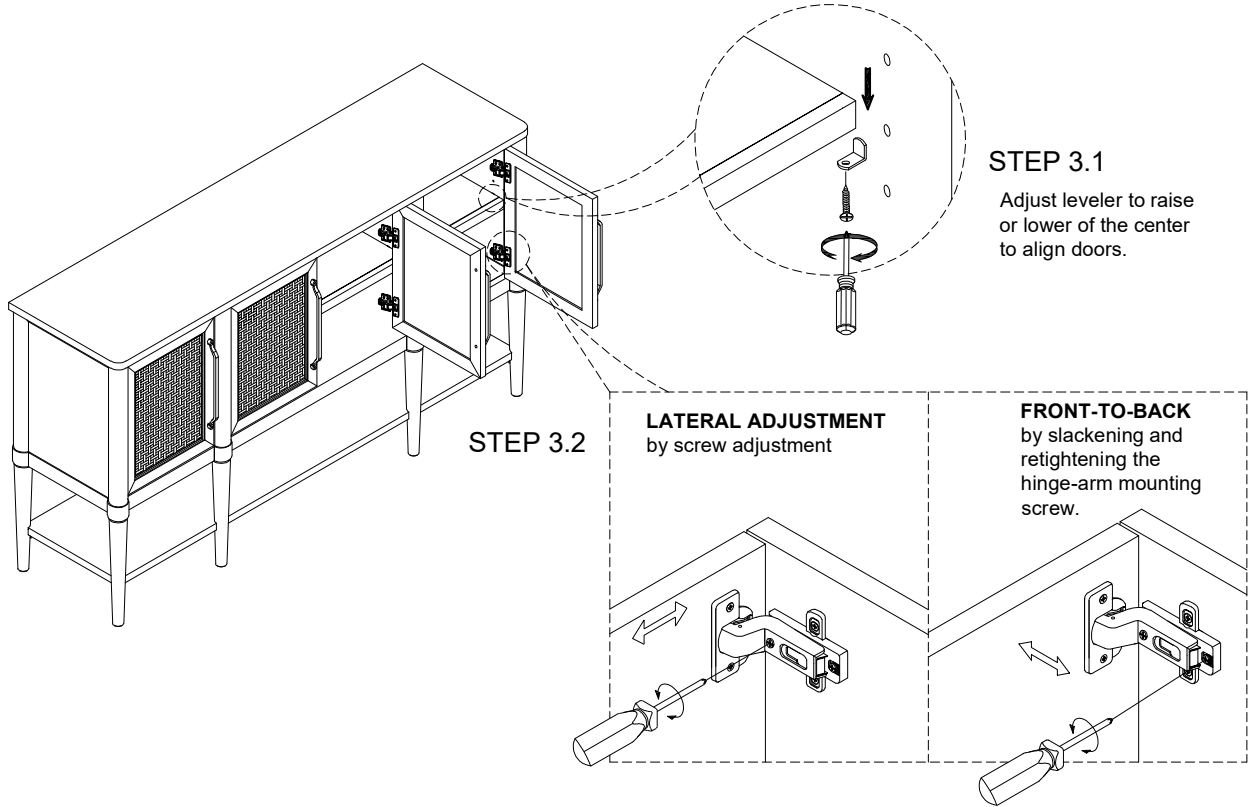

STEP 4

★ Remark: there is a tip restraint kit provided on the back of this product. Please read the directions thoroughly and install Immediately when placed in home.

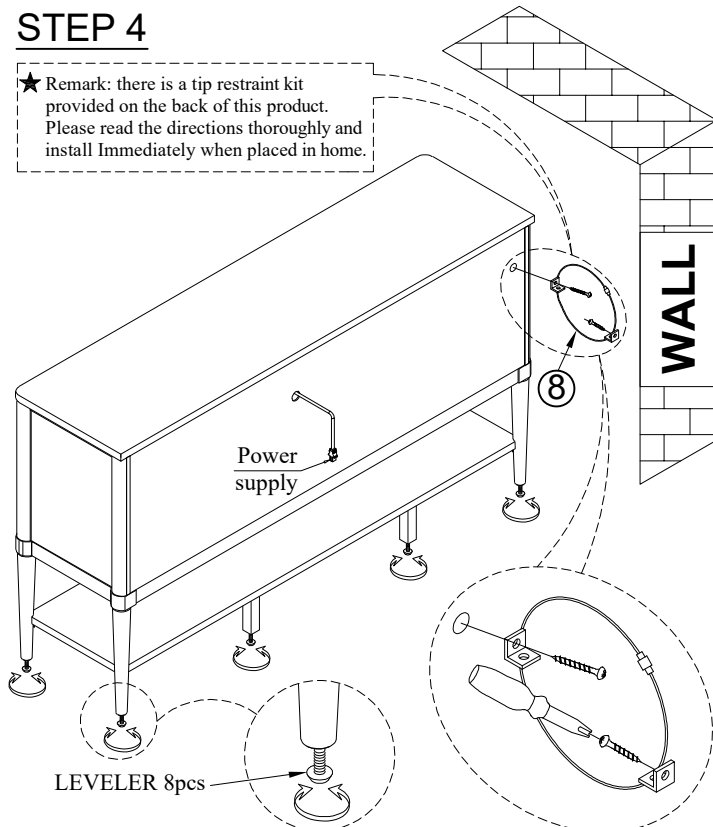

COMPLETED

