

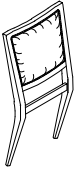







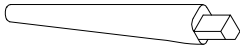

ASSEMBLY INSTRUCTIONS

MODEL # : 338- 510 UPHOLSTERED DINING CHAIR (V#12600HMYV)

NOTE: KEEP THIS DOCUMENT FOR REFERENCE IN CASE PARTS ARE NEEDED
DO NOT TIGHTEN SCREWS UNTIL COMPLETELY ASSEMBLED!!
UNIT SHOULD BE ASSEMBLED BY TWO OR MORE PEOPLE.

No	PART LIST		Q'TY
A		BACK FRAME	1PC
B		SEAT FRAME	1PC
C		FRONT LEGS	2PCS

No	HARDWARE LIST			Q'TY
1		FLAT WASHER	$\varnothing 5/16 \times 19 \times 1.5\text{mm}$	8PCS
2		LOCK WASHER	$\varnothing 5/16 \times 13 \times 1\text{mm}$	8PCS
3		ALLEN BOLT	$\varnothing 5/16 \times 2-1/2"$	8PCS
4		FLAT WASHER	$\varnothing 1/4 \times 19 \times 1.5\text{mm}$	2PCS
5		LOCK WASHER	$\varnothing 1/4 \times 13 \times 1\text{mm}$	2PCS
6		ALLEN BOLT	$\varnothing 1/4 \times 1-3/4"$	2PCS
7		ALLEN KEY	$2-3/8 \times 4\text{mm}$	1PC

ASSEMBLY INSTRUCTIONS

MODEL # : 338- 510 UPHOLSTERED DINING CHAIR (V#12600HMVY)

NOTE: KEEP THIS DOCUMENT FOR REFERENCE IN CASE PARTS ARE NEEDED
DO NOT TIGHTEN SCREWS UNTIL COMPLETELY ASSEMBLED!!
UNIT SHOULD BE ASSEMBLED BY TWO OR MORE PEOPLE.

STEP 1

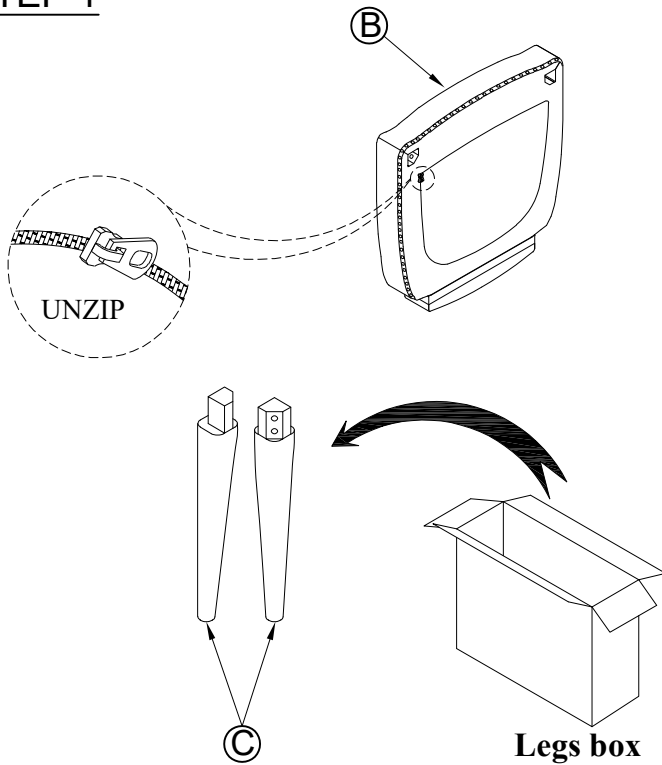

STEP 2

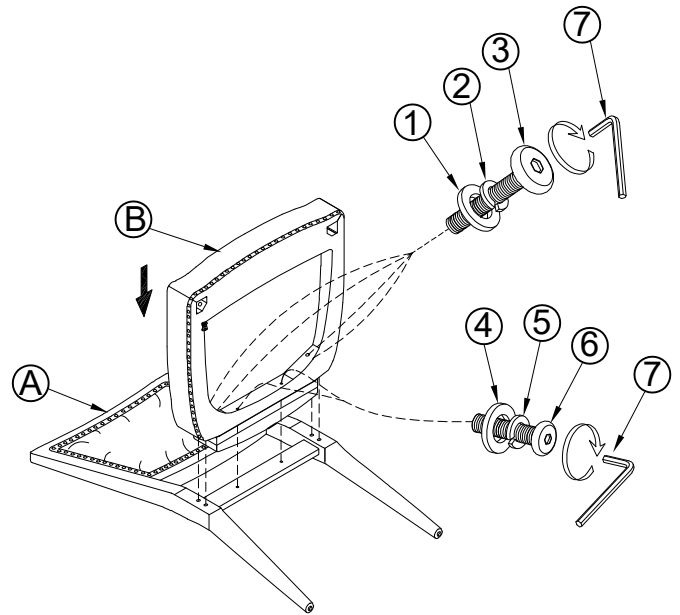

STEP 3

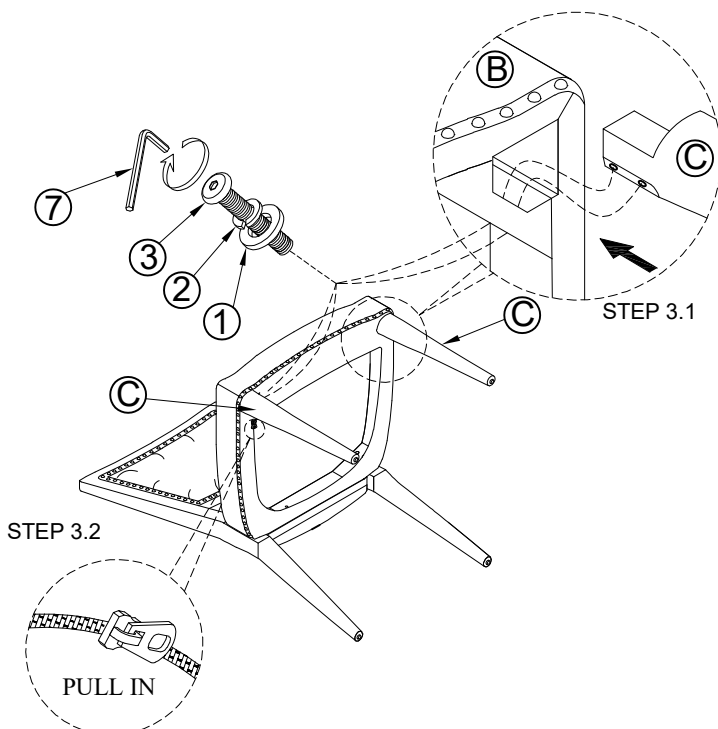

COMPLETED

