





ASSEMBLY INSTRUCTIONS





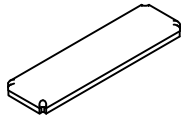

MODEL # : 338-160

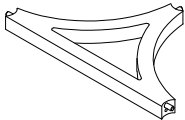
BENCH

(V#12600HVMY)

NOTE: KEEP THIS DOCUMENT FOR REFERENCE IN CASE PARTS ARE NEEDED
DO NOT TIGHTEN SCREWS UNTIL COMPLETELY ASSEMBLED!!
UNIT SHOULD BE ASSEMBLED BY TWO OR MORE PEOPLE.

No	PART LIST		Q'TY
A		SEAT FRAME	1PC
B		LEFT FRONT LEGS	2PCS
C		RIGHT BACK LEGS	2PCS
D		CENTER LEGS	2PCS
E		SIDE STRETCHER	2PCS

No	HARDWARE LIST		Q'TY
1		FLAT WASHER	12PCS
2		LOCK WASHER	12PCS
3		ALLEN BOLT	8PCS
4		ALLEN BOLT	4PCS
5		ALLEN KEY	1PC
6		SCREW	6PCS

ASSEMBLY INSTRUCTIONS

MODEL # : 338-160

BENCH

(V#12600HMY)

NOTE: KEEP THIS DOCUMENT FOR REFERENCE IN CASE PARTS ARE NEEDED
DO NOT TIGHTEN SCREWS UNTIL COMPLETELY ASSEMBLED!!
UNIT SHOULD BE ASSEMBLED BY TWO OR MORE PEOPLE.

STEP 1

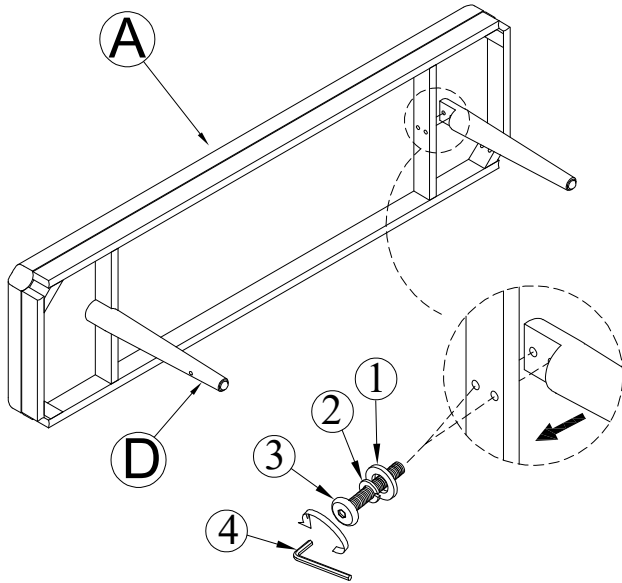

STEP 2

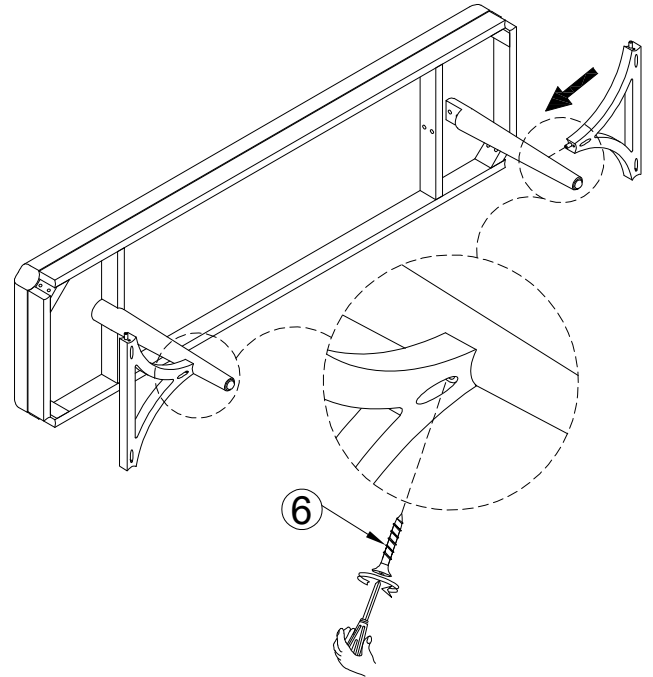

STEP 3

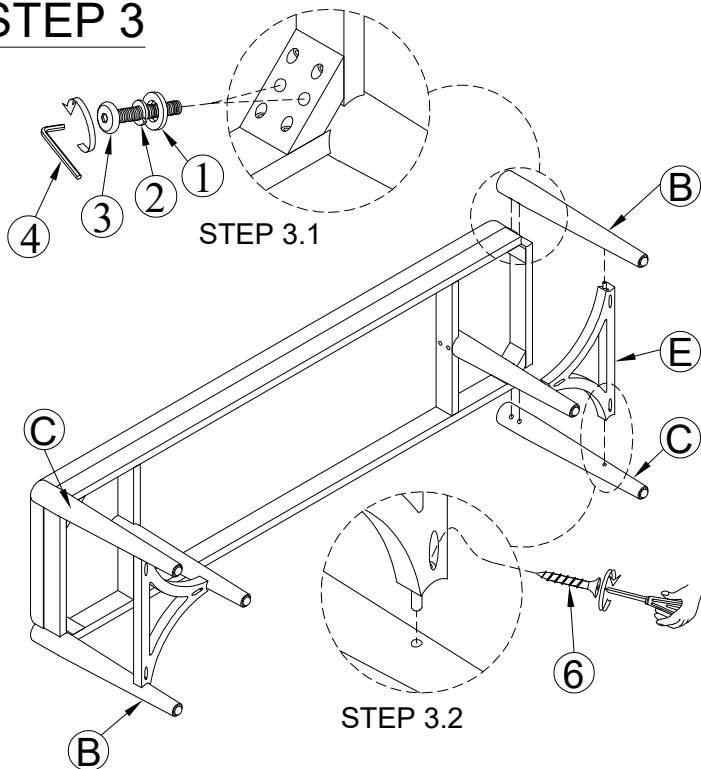

COMPLETED

