

ASSEMBLY INSTRUCTION

ITEM # : 2868-140 MIRROR

**NOTE : THIS ITEM NOT RECOMMENDED FOR COMMERCIAL USE
KEEP THIS DOCUMENT FOR REFERENCE IN CASE PARTS ARE NEEDED**

DO NOT TIGHTEN SCREWS UNTIL COMPLETELY ASSEMBLED !!

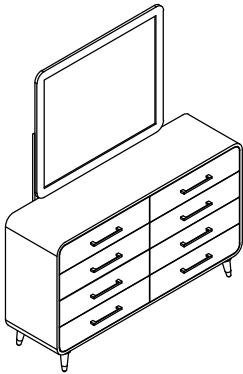

PARTS LIST			
NO.	SKETCH	DESCRIPTION	QTY
A		MIRROR	1 PC
B		MIRROR SUPPORT	2 PCS
C		DRESSER	1 PC

HARDWARE LIST			
NO.	SKETCH	DESCRIPTION	QTY
1		JCBC BOLT	8 PC
2		SPRING WASHER	8 PC
3		FLAT WASHER	8 PC
4		M4 ALLEN KEY	1 PC

TOOLS REQUIRED (NOT PROVIDED)

PHILIP SCREW DRIVER	1 PC
---------------------	------

STEP 1: Attach the Mirror Supports (B) to Mirror (A) and Dresser (C) by using Allen Key M4 (4) to tight Flat Washer (3), Spring Washer (2) and Allen Bolt (1).

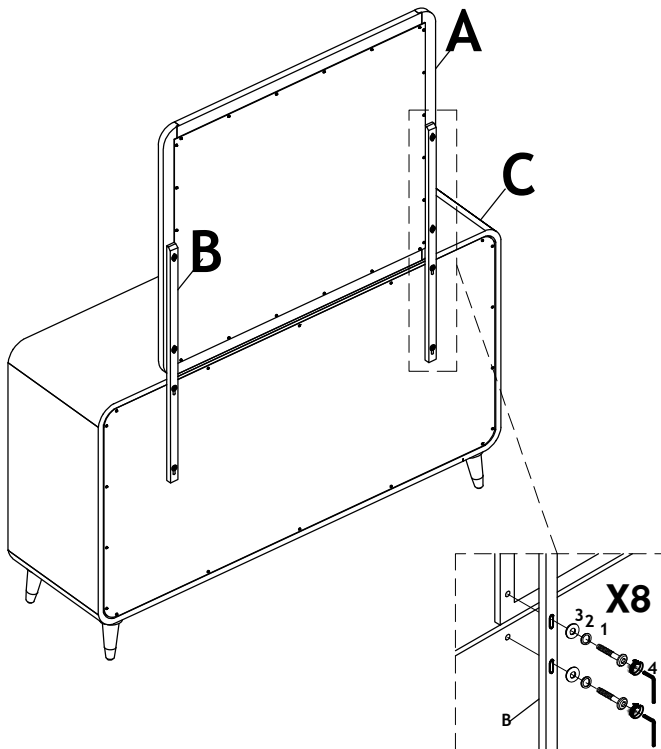

STEP 2 : Assembly the tipping Restraint (5) . the Tipping restraint must be attached at back of Dresser above and on the right or left

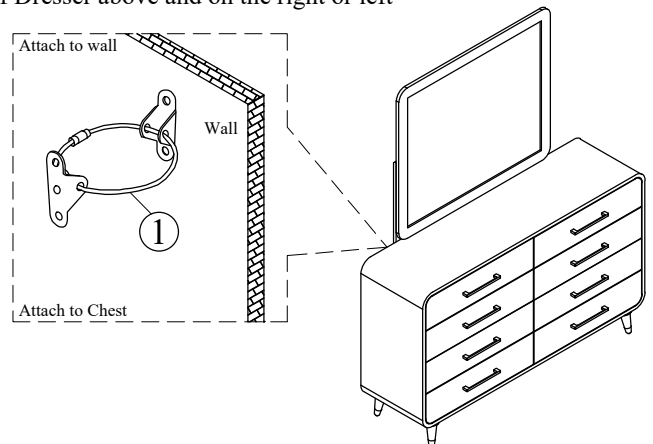

Completed Assembly

