

ASSEMBLY INSTRUCTIONS

ITEM # : 211-130 DRESSER

DO NOT TIGHTEN SCREWS UNTIL COMPLETELY ASSEMBLED !!



PARTS LIST			
NO	SKETCH	DESCRIPTION	QTY
A		DRESSER	1 PCS
B		LEG	4 PCS
C		SUPPORT LEG	1 PCS

HARDWARE LIST				
NO	OUTLOOK	DESCRIPTION	SIZE	QTY
1		TIPPING RESTRAINT	—	1 PCS
2		JCBC	M6 x P1.0 x 20MM	12 PCS
		SPRING WASHER	M6 x 11MM	12 PCS
		FLAT WASHER	M6 x 18MM	12 PCS
3		ALLEN KEY	M4 x 55MM	1 PCS

TOOLS REQUIRED (NOT PROVIDED)	
PHILIP SCREW DRIVER	1 PCS

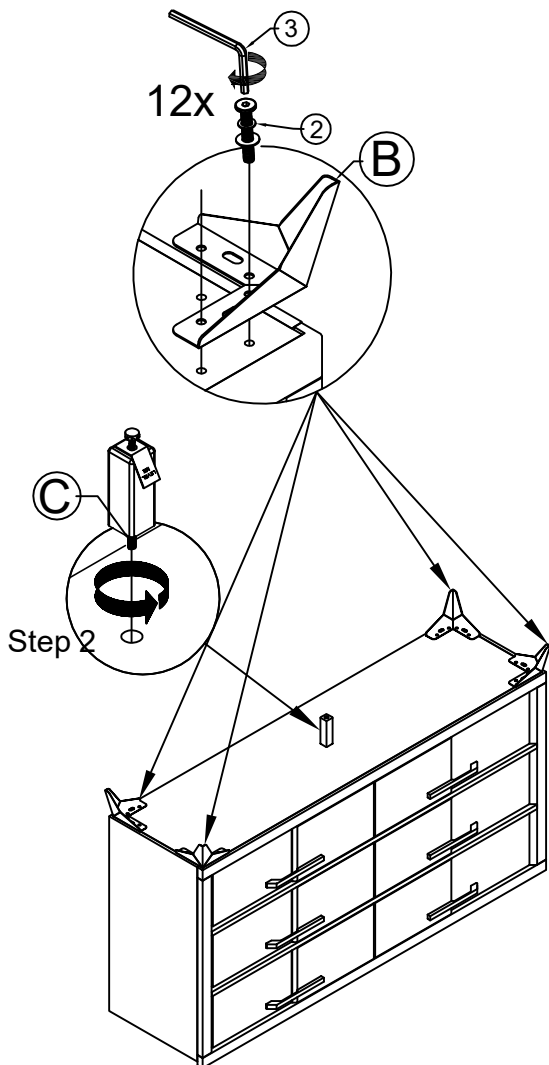

STEP 3 : Move the Dresser (A) into final position and use tipping restraint (1) attach to wall

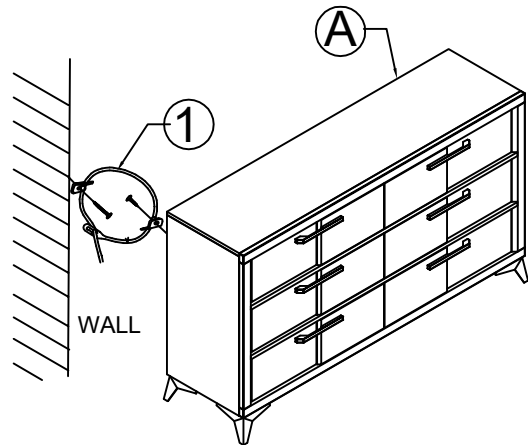

COMPLETED ASSEMBLY

