







# ASSEMBLY INSTRUCTIONS

ITEM # : 211-105HQ QUEEN HEADBOARD

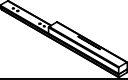
DO NOT TIGHTEN SCREWS UNTIL COMPLETELY ASSEMBLED !!

PARTS LIST			
NO	SKETCH	DESCRIPTION	QTY
A		HEADBOARD	1 PCS
B		HEADBOARD LEG L	1 PCS
C		HEADBOARD LEG R	1 PCS
D		BOTTOM RAIL	1 PCS

HARDWARE LIST				
NO	OUTLOOK	DESCRIPTION	SIZE	QTY
1		JCBC	M6 x P1.0 x 35MM	8 PCS
		SPRING WASHER	M6 x 11MM	8 PCS
		FLAT WASHER	M6 x 18MM	8 PCS
2		ALLEN KEY	M4 x 55MM	1 PCS
3		ADAPTER	-----	1 PCS

COMPLETED  
ASSEMBLY

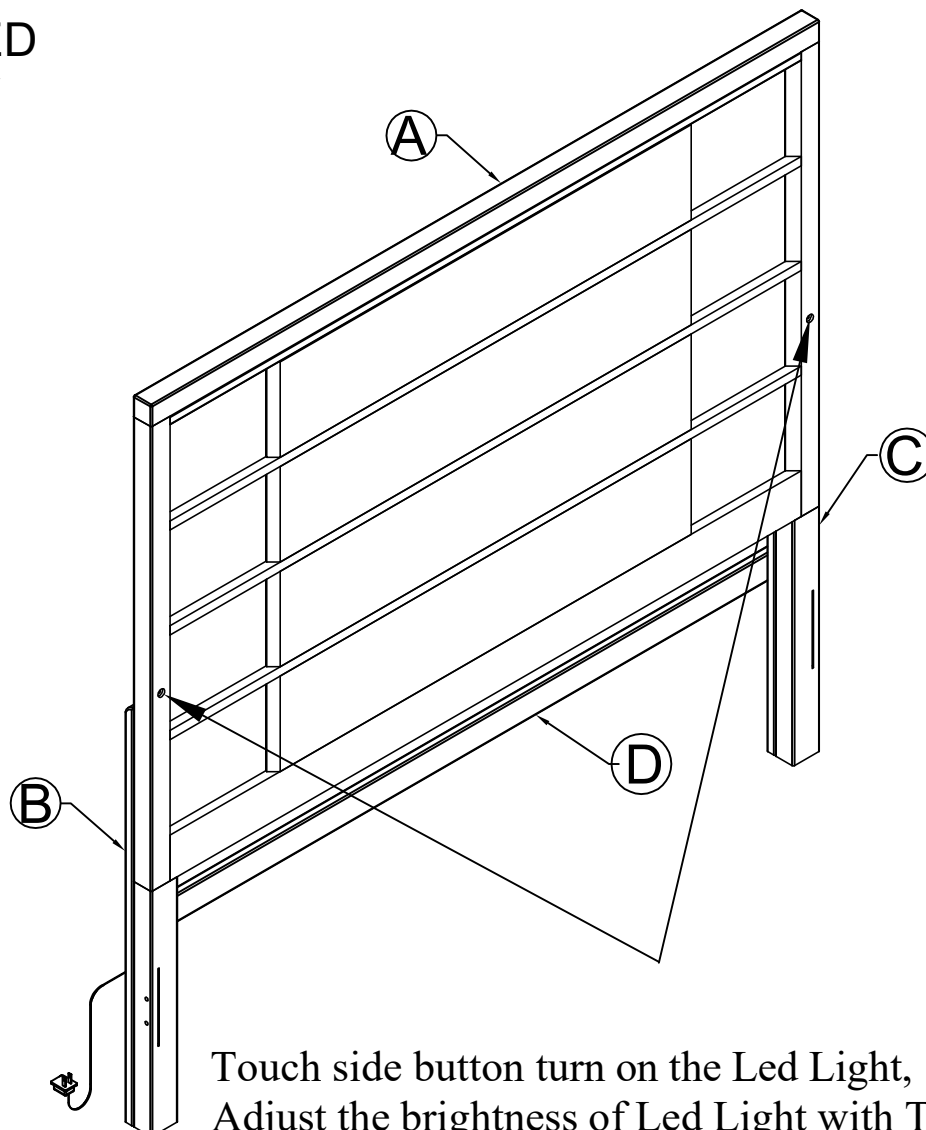

Touch side button turn on the Led Light,  
Adjust the brightness of Led Light with Touch Button.  
Turn on or off the Led Light with Touch Button.

# ASSEMBLY INSTRUCTIONS

ITEM # : 211-105HQ QUEEN HEADBOARD

DO NOT TIGHTEN SCREWS UNTIL COMPLETELY ASSEMBLED !!

## STEP 1

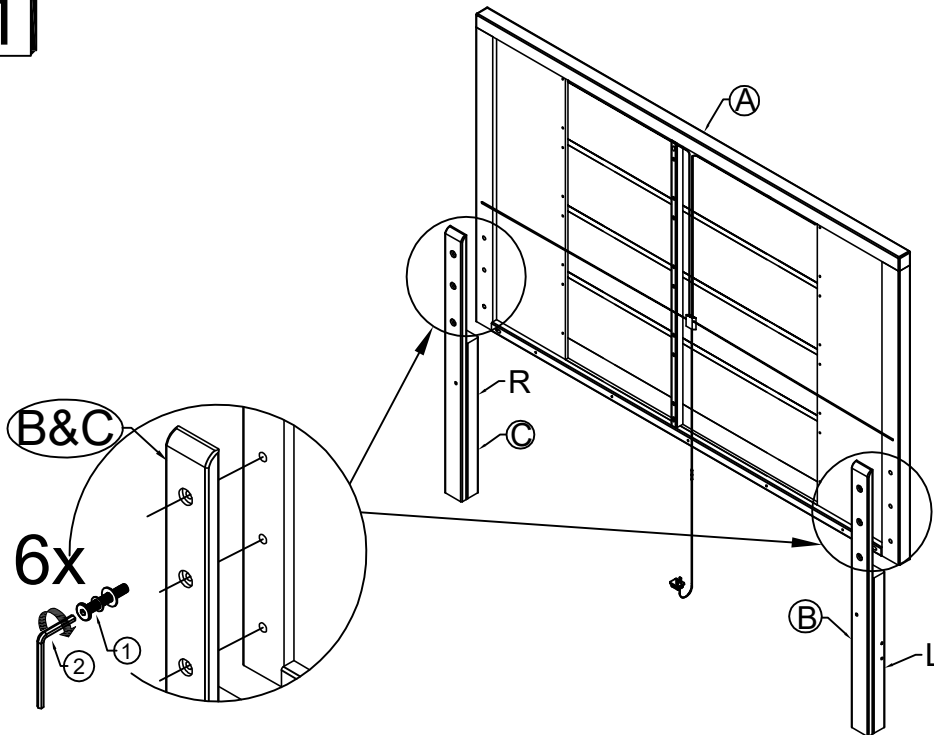

## STEP 2

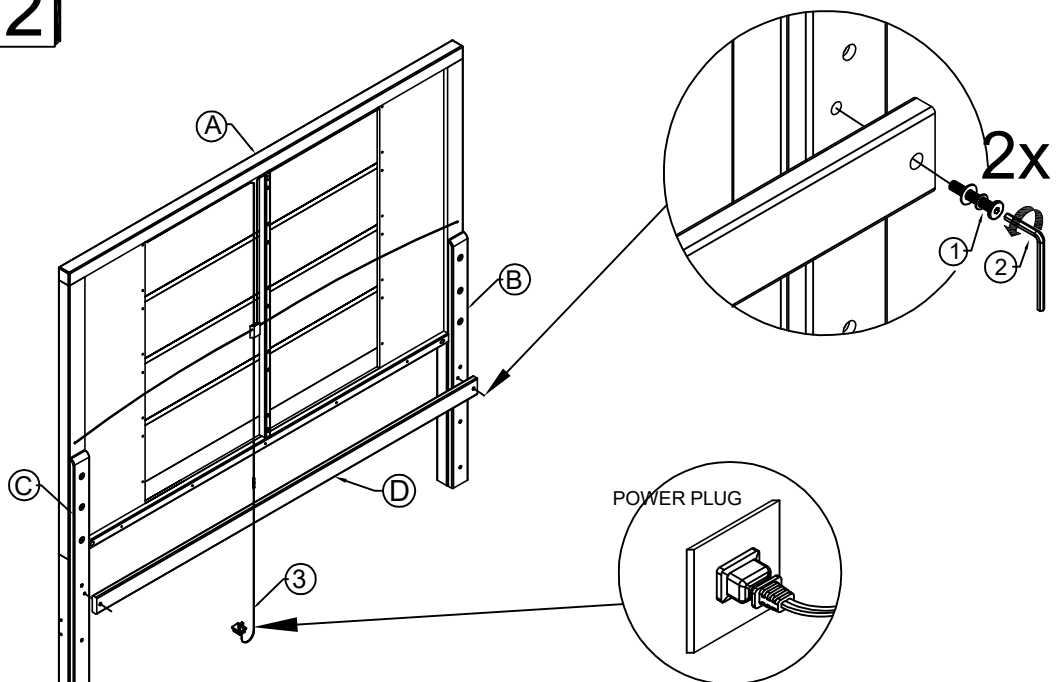

Please insert the Adapter (3) to the power plug, to turn on the Led Light