



# ASSEMBLY INSTRUCTIONS

**MODEL # : 1988-524 TRADITIONAL SERVER (V#12600KJIC1)**

**NOTE: THIS ITEM NOT RECOMMENDED FOR COMMERCIAL USE  
KEEP THIS DOCUMENT FOR REFERENCE IN CASE PARTS ARE NEEDED  
DO NOT TIGHTEN SCREWS UNTIL COMPLETELY ASSEMBLE !!**

PART LIST:			
No.	Description	Sketch	Quantity
A	SERVER		1 PC

HARDWARE LIST				
NO.	Description	Sketch	Size	Q'ty
1	TIPPING RESTRAINT			1SET

## STEP 1

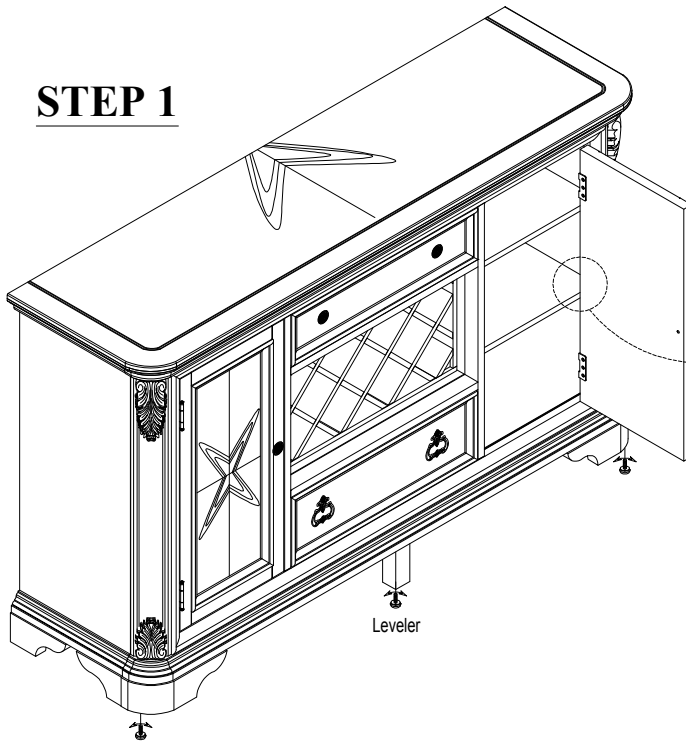

For shipping purposes, bottom secured in place. To adjust, please remove screws under each shelf pin. Re-place pins and shelf to desired position. It is recommended to re-secure screws to shelf.

**A**

## STEP 2

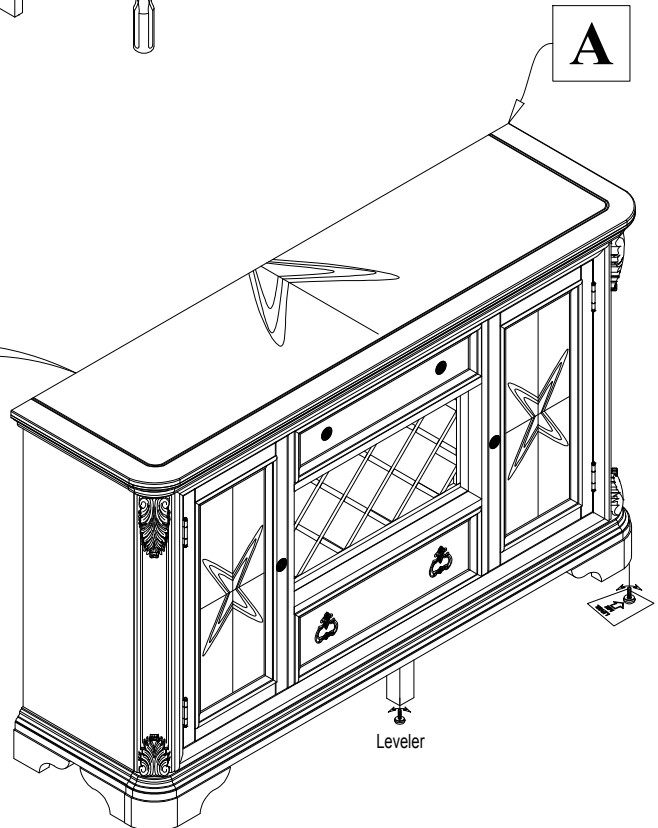
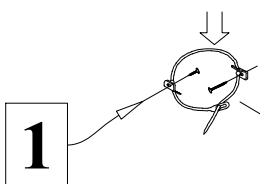

★ Remark: There is a tipping restraint kit attached to the back of this product. Please read the directions thoroughly and install immediately before use.







# ASSEMBLY INTRUCTIONS

**MODEL # : 1988-500 TRADITIONAL DINING TABLE (V#12600KJIC1)**

**NOTE: THIS ITEM NOT RECOMMENDED FOR COMMERCIAL USE  
KEEP THIS DOCUMENT FOR REFERENCE IN CASE PARTS ARE NEEDED  
DO NOT TIGHTEN SCREWS UNTIL COMPLETELY ASSEMBLE !!**

PART LISTS			
No.	Description	Sketch	Q'ty
A	TABLE TOP		1PC
B	TABLE LEAF		2PCS
C	TABLE LEG		4PCS

HARDWARE LISTS				
No.	Description	Sketch	Size	Q'ty
1	BOLT		Ø5/16"*2-1/2"	8PCS
2	SPRING WASHER		Ø5/16"*Ø13*1.2	8PCS
3	FLAT WASHER		Ø5/16"*Ø19*1.8	8PCS
4	ALLEN KEY		L57*4MM	1PC

## STEP 1

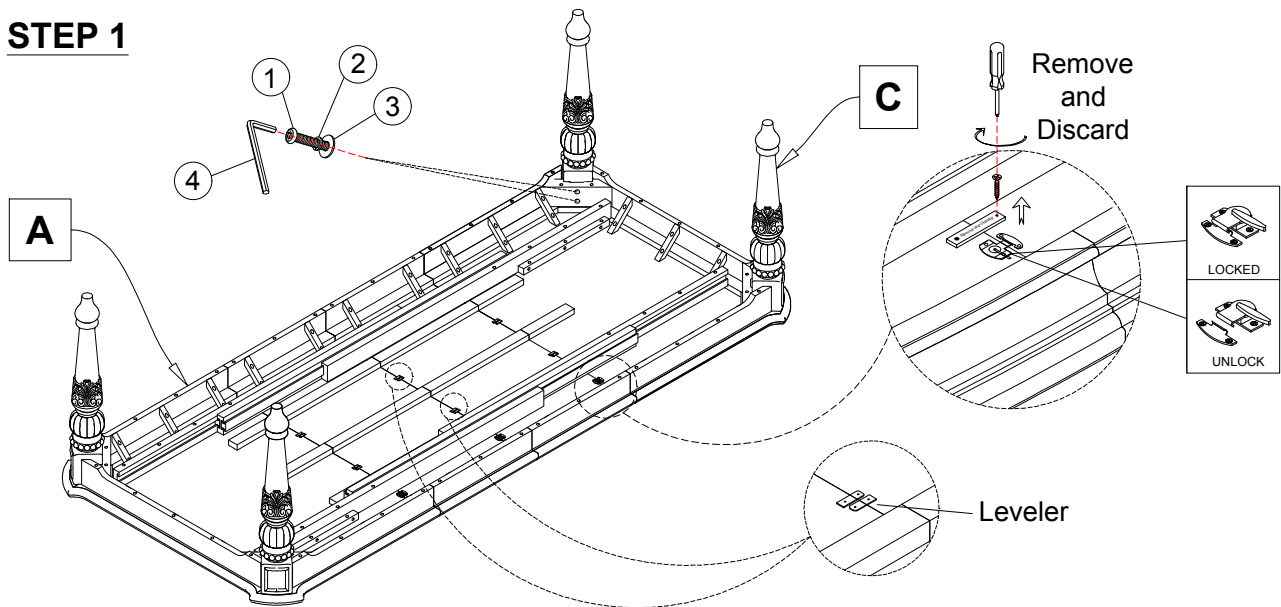

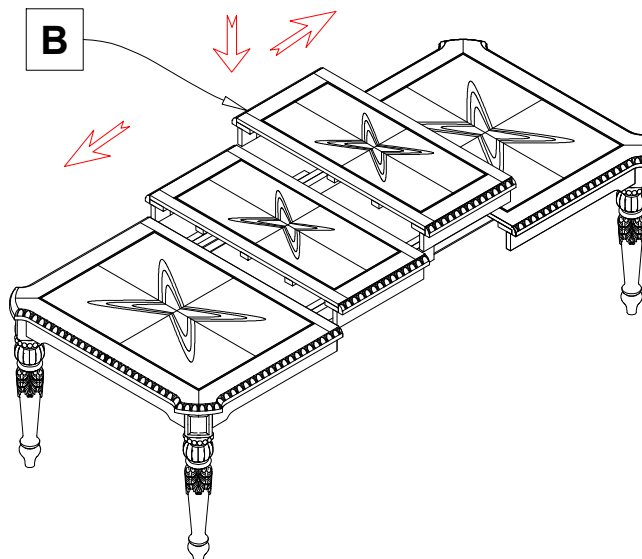

## STEP 2





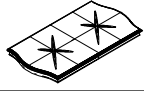
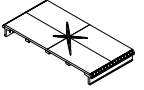
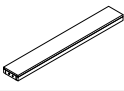

# ASSEMBLY INTRUCTIONS

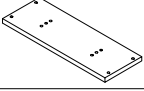
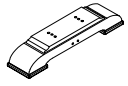
**MODEL # : 1988-501BA/501TP TRESTLE TABLE (V#12600KJIC1)**

**NOTE: THIS ITEM NOT RECOMMENDED FOR COMMERCIAL USE  
KEEP THIS DOCUMENT FOR REFERENCE IN CASE PARTS ARE NEEDED  
DO NOT TIGHTEN SCREWS UNTIL COMPLETELY ASSEMBLE !!**

PART LISTS			
No.	Description	Sketch	Q'ty
A	TABLE TOP		1PC
B	TABLE LEAF		1PC
C	BOTTOM STRETCHER		1PC
D	TABLE LEGS		4PCS
E	MOUNTING PLATES		2PCS
F	TABLE BASE		2PCS

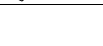
HARDWARE LISTS				
No.	Description	Sketch	Size	Q'ty
1	BOLT		Ø5/16**2"	20PCS
2	BOLT		Ø5/16**3"	8PCS
3	SPRING WASHER		Ø5/16**Ø13*1.2	28PCS
4	FLAT WASHER		Ø5/16**Ø19*1.8	28PCS
5	ALLEN KEY		L57*4MM	1PC

## STEP 1

## STEP 2

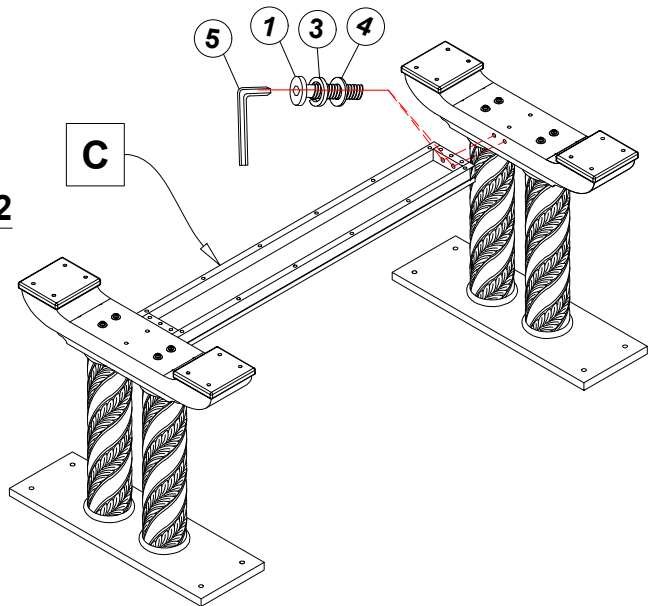
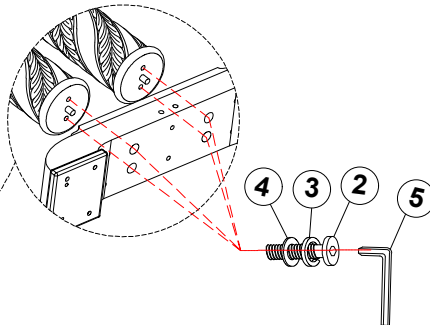
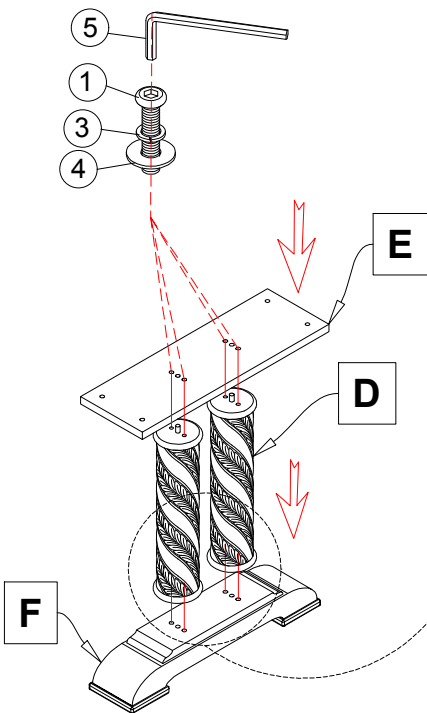

# ASSEMBLY INTRUCTIONS

MODEL # : 1988-501BA/501TP TRESTLE TABLE (V#12600KJIC1)

In Step 3-1; 3-2, Please do not over tighten bolts until the assembly is complete.

## STEP 3-1

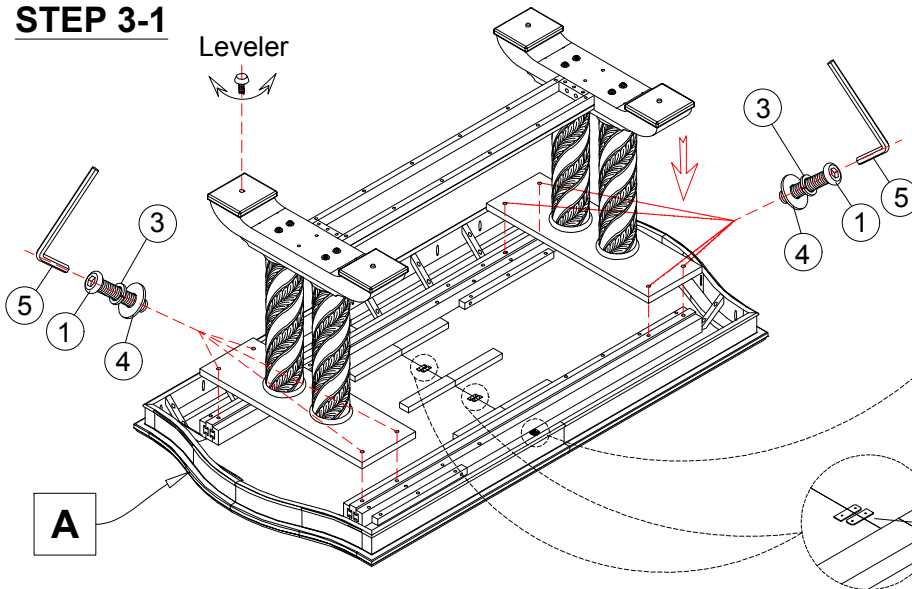

## STEP 3-2

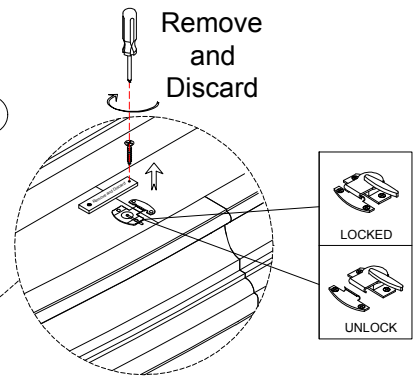

## STEP 3-3

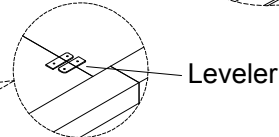

## STEP 4

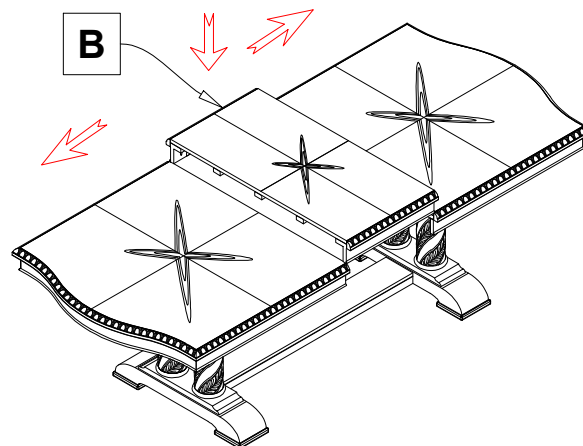



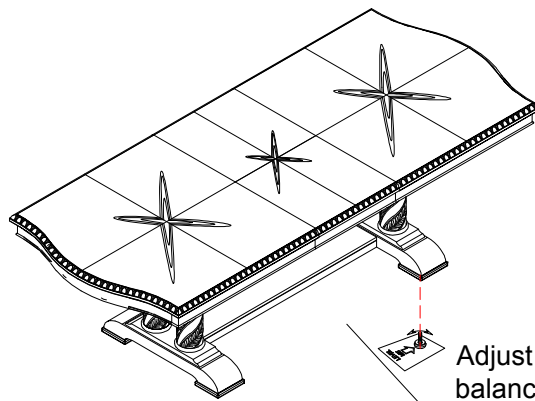

## FINAL









# ASSEMBLY INTRUCTIONS

**MODEL # : 1988-511 TRADITIONAL ARM CHAIR (V#12600KJIC1)**

**NOTE: THIS ITEM NOT RECOMMENDED FOR COMMERCIAL USE  
KEEP THIS DOCUMENT FOR REFERENCE IN CASE PARTS ARE NEEDED  
DO NOT TIGHTEN SCREWS UNTIL COMPLETELY ASSEMBLE !!**

PART LISTS			
No.	Description	Sketch	Q'ty
A	CHAIR BACK		1PC
B	SEAT BOX W/ SEAT CUSHION		1PC
C	FRONT LEG		2PCS
D	ARM (L & R)		2PCS

HARDWARE LISTS				
No.	Description	Sketch	Size	Q'ty
1	BOLT		Ø5/16"*1-1/2"	8PCS
2	BOLT		Ø5/16"*2-1/4"	4PCS
3	BOLT		Ø5/16"*3-1/4"	4PCS
4	SPRING WASHER		Ø5/16"*Ø13*1.2	16PCS
5	FLAT WASHER		Ø5/16"*Ø19*1.8	14PCS
6	ALLEN KEY		L57*4MM	1PC
7	WOOD PLUS			2PCS

## STEP 1

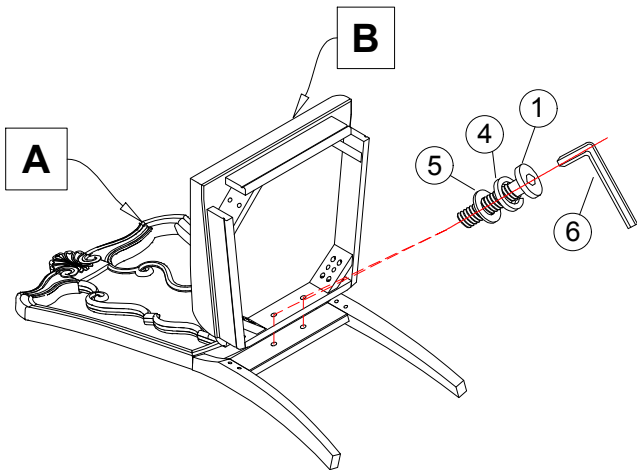

## STEP 3

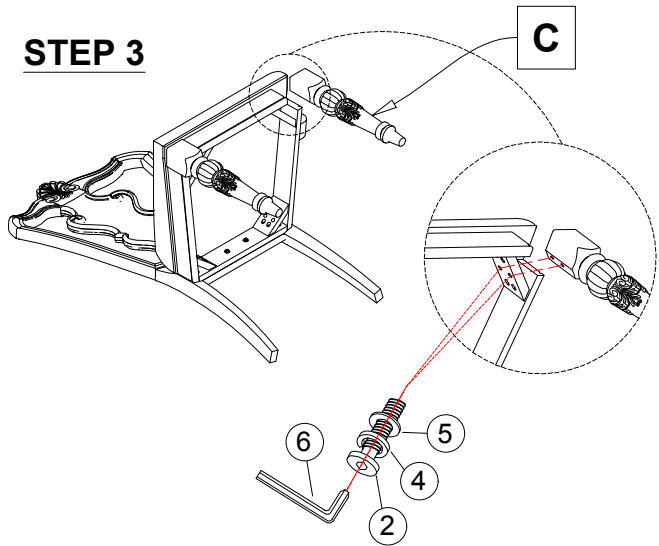

## STEP 2

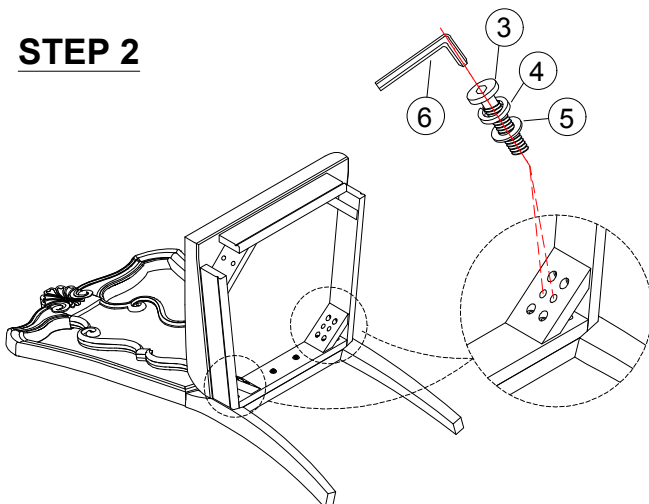

## STEP 4-1

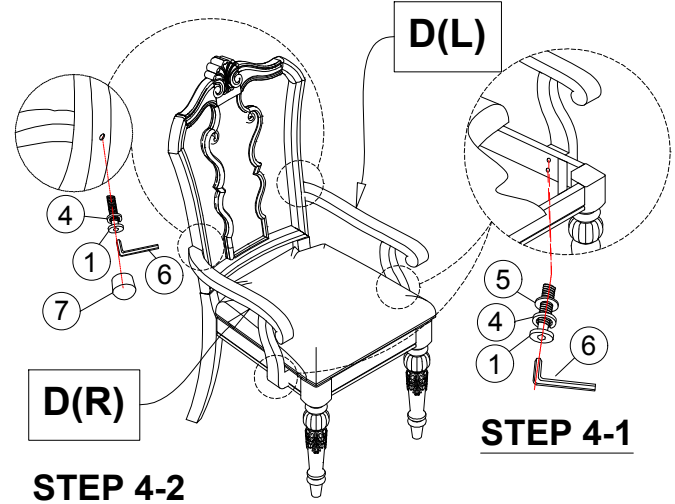







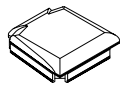

## STEP 4-2

# ASSEMBLY INTRUCTIONS

**MODEL # : 1988-510 TRADITIONAL SIDE CHAIR (V#12600KJIC1)**

**NOTE: THIS ITEM NOT RECOMMENDED FOR COMMERCIAL USE  
KEEP THIS DOCUMENT FOR REFERENCE IN CASE PARTS ARE NEEDED  
DO NOT TIGHTEN SCREWS UNTIL COMPLETELY ASSEMBLE !!**

PART LISTS			
No.	Description	Sketch	Q'ty
A	CHAIR BACK		1PC
B	SEAT BOX W/ SEAT CUSHION		1PC
C	FRONT LEG		2PCS

HARDWARE LISTS				
No.	Description	Sketch	Size	Q'ty
1	BOLT		Ø5/16**1-1/2"	2PCS
2	BOLT		Ø5/16**2-1/4"	4PCS
3	BOLT		Ø5/16**3-1/4"	4PCS
4	SPRING WASHER		Ø5/16**Ø13*1.2	10PCS
5	FLAT WASHER		Ø5/16**Ø19*1.8	10PCS
6	ALLEN KEY		L57*4MM	1PC

## STEP 1

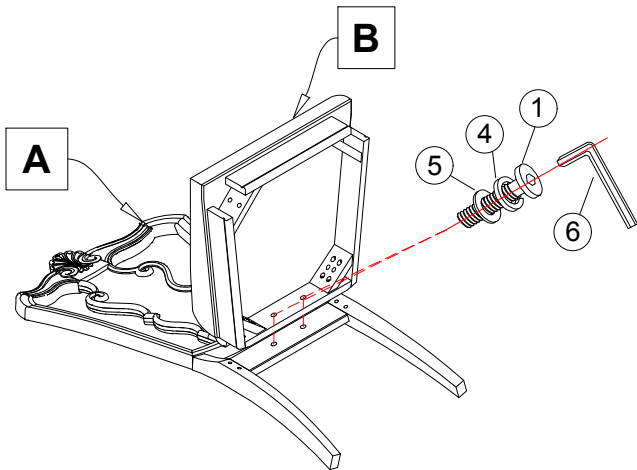

## STEP 3

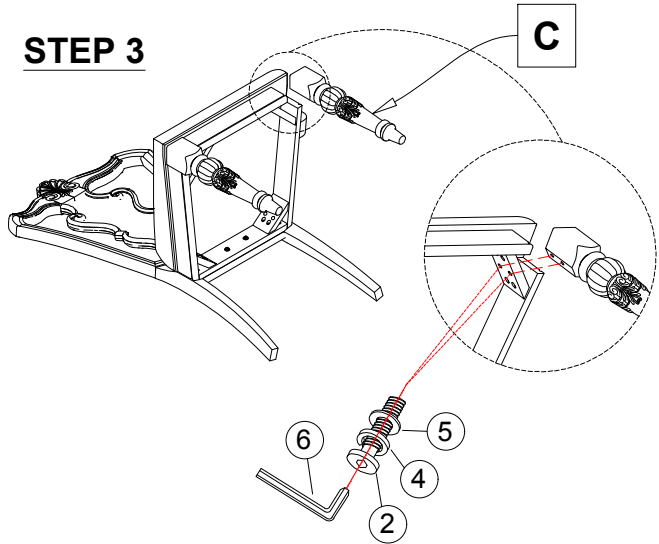

## STEP 2

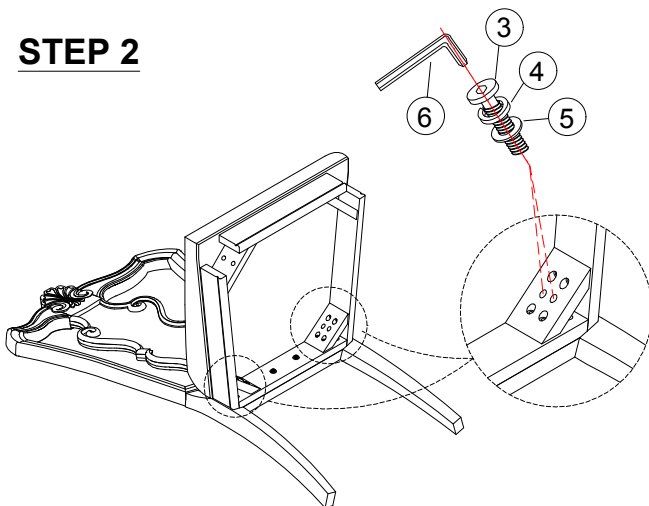

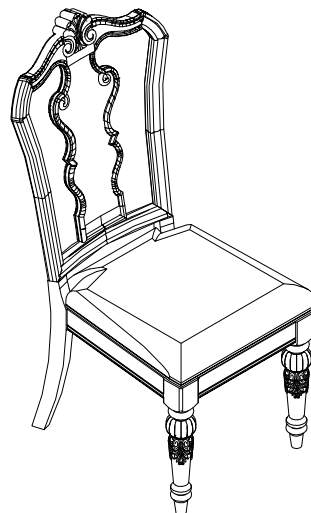

## FINAL





# ASSEMBLY INTRUCTIONS

**MODEL # : 1988-512 TRADITIONAL UPH WING CHAIR (V#12600KJIC1)**

**NOTE: THIS ITEM NOT RECOMMENDED FOR COMMERCIAL USE  
KEEP THIS DOCUMENT FOR REFERENCE IN CASE PARTS ARE NEEDED  
DO NOT TIGHTEN SCREWS UNTIL COMPLETELY ASSEMBLE !!**

PART LISTS			
No.	Description	Sketch	Q'ty
A	SEAT FRAME		1PC
B	BACK LEG		2PCS
C	FRONT LEG		2PCS

HARDWARE LISTS				
No.	Description	Sketch	Size	Q'ty
1	BOLT		Ø5/16**2-1/4"	8PCS
2	SPRING WASHER		Ø5/16**Ø13*1.2	8PCS
3	FLAT WASHER		Ø5/16**Ø19*1.8	8PCS
4	ALLEN KEY		L57*4MM	1PC

## STEP 1

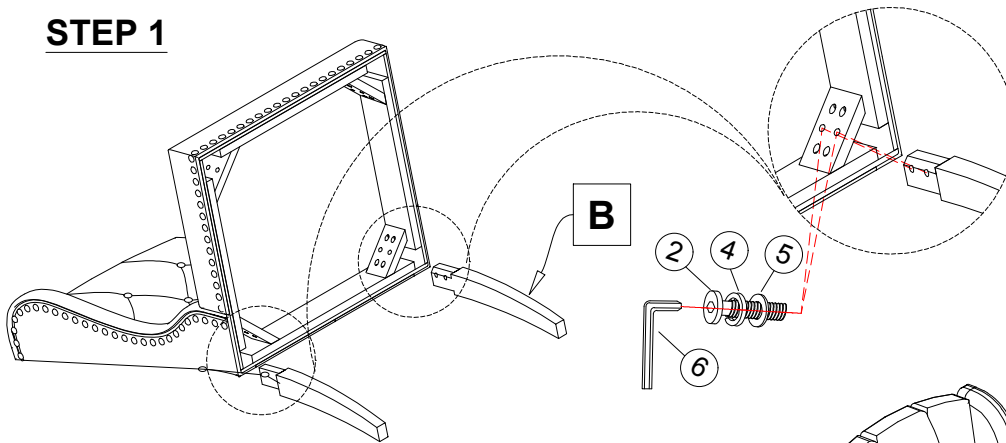

## FINAL

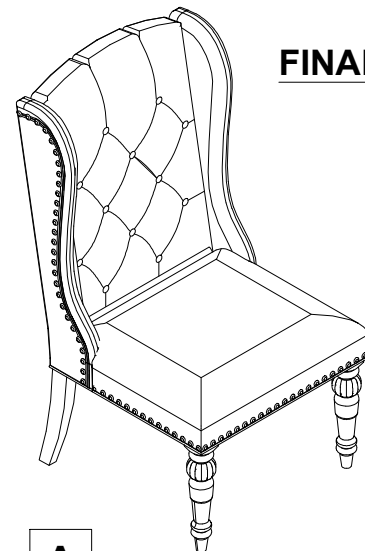

## STEP 2

