























ASSEMBLY INSTRUCTIONS

MODEL:#1800-104

V#12600JG1 1OF2

NOTE:THIS ITEM IS NOT RECOMMENDED FOR COMMERCIAL USE
KEEP THIS DOCUMENT FOR REFERENCE IN CASE PARTS ARE NEEDED

DO NOT TIGHTEN SCREWS UNTIL COMPLETELY ASSEMBLED!!

NO.		DESCRIPTION	QTY	NO.		DESCRIPTION	QTY
A		HEADBOARD TWIN&FULL SIZE	1PC	J		BOLTS M6X40MM	14PCS
B		FOOTBOARD TWIN&FULL SIZE	1PC	K		BOLTS M6X50MM	2PCS
C		EXTENSION LEG TWIN&FULL SIZE	2PCS	M		BOLTS M8X55MM	4PCS
L		SIDE RALL(LEFT) TWIN&FULL SIZE	2PCS	N		BOLTS M8X16MM	8PCS
R		SIDE RALL(RIGHT) TWIN&FULL SIZE	2PCS	O		M8	4PCS
D		CENTER RAIL	1PC	P		M6	10PCS
E		BRACKET (CENTER RAIL)	2PCS	Q		M8	8PCS
F		CROSS BAR(HEADBOARD)	1PC	S		M6	14PCS
G		METAL SLATS(FRAME)	4PCS	T		M8	2PCS
H		CENTER SUPPORT LEGS	4PCS	U		#4
	2PCS
I		BOLTS M6X16MM	4PCS	V		#5	2PCS

STEP1

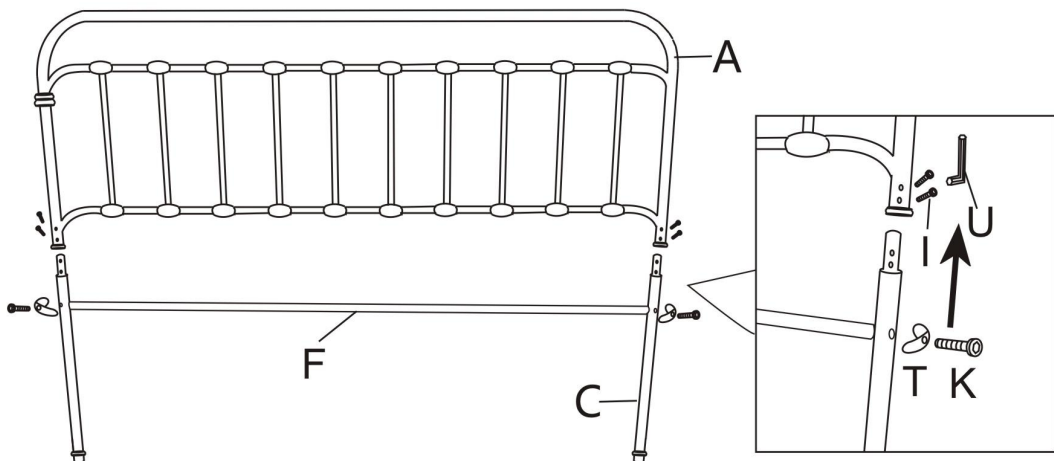

STEP2

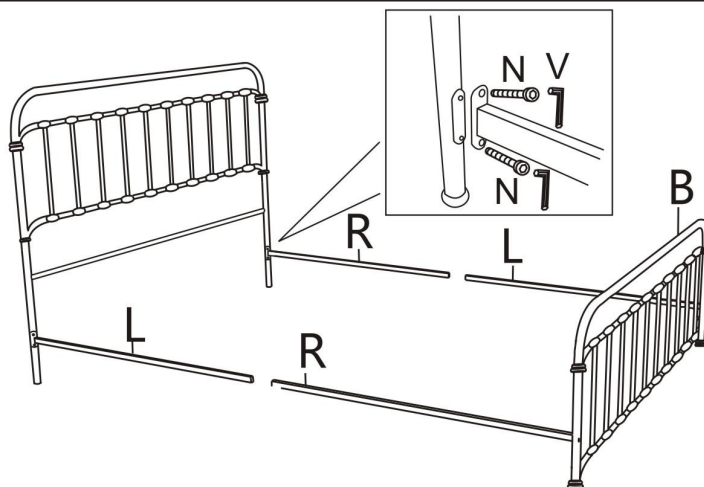

ASSEMBLY INSTRUCTIONS

MODEL:#1800-104

V#12600JG1

2OF2

NOTE: THIS ITEM IS NOT RECOMMENDED FOR COMMERCIAL USE
KEEP THIS DOCUMENT FOR REFERENCE IN CASE PARTS ARE NEEDED

DO NOT TIGHTEN SCREWS UNTIL COMPLETELY ASSEMBLED!!

STEP3

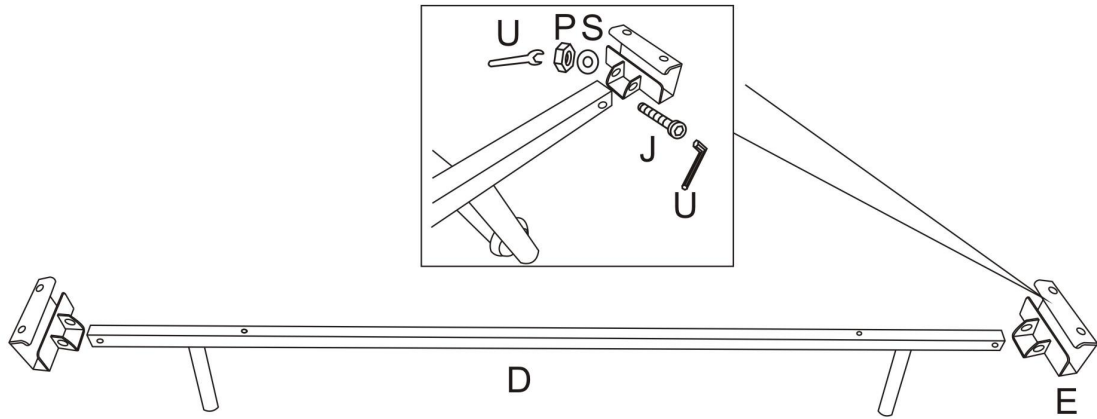

STEP4

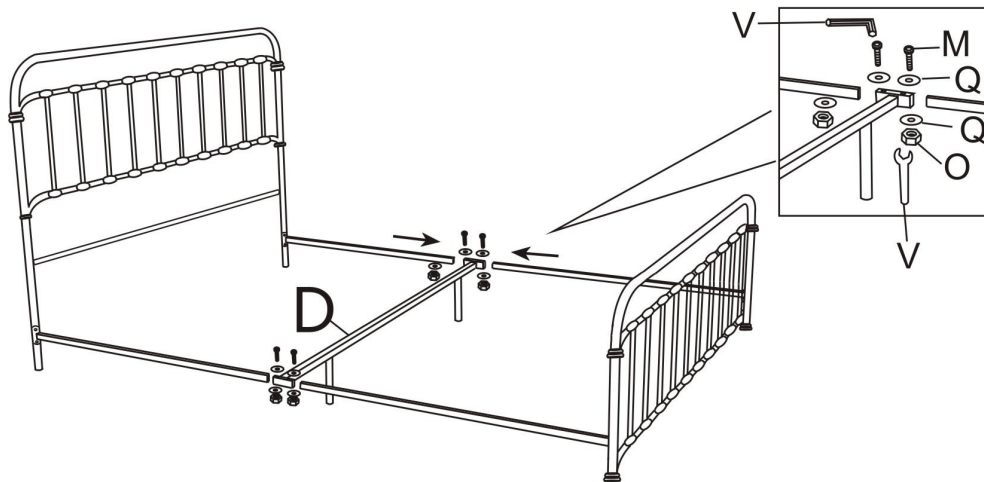

STEP5

