









# ASSEMBLY INSTRUCTION

MODEL: SKU#1372-104,1372-105

**NOTE: THIS ITEM NOT RECOMMENDED FOR COMMERCIAL USE.  
KEEP THIS DOCUMENT FOR REFERENCE IN CASE PARTS ARE NEEDED.**

**DO NOT TIGHTEN SCREWS UNTIL COMPLETELY ASSEMBLED !!  
DO NOT STEP ON OR PLACE OBJECTS ON USB CABLE DURING ASSEMBLY.**



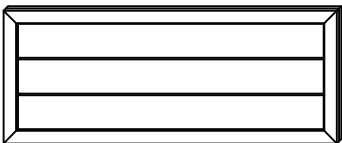
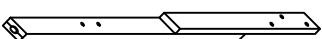
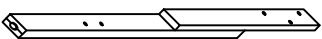

HARDWARE LIST				
NO.		DESCRIPTION		QTY
1		JCBC BOLT	M8 x 20mm	8 PCS
2		JCBC BOLT	M8 x 30mm	8 PCS
3		JCBC BOLT	M8 x 35mm	6 PCS
4		JCBC BOLT	M6 x 35mm	4 PCS
5		SPRING WASHER	M8 x 14mm	14 PCS
6		FLAT WASHER	M8 x 22mm	14 PCS
7		CSK SCREW	M4 x 32mm	8 PCS
8		ALLEN WRENCH	M4 x 65mm	1 PC
9		ALLEN WRENCH	M5 x 65mm	1 PC

PARTS LIST			
NO.		DESCRIPTION	QTY
A		HEADBOARD (USB CABLE WITHIN)	1
B		HEADBOARD LEG (L)	1
C		HEADBOARD LEG (R)	1

MORE PARTS IN NEXT PAGE...

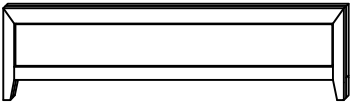
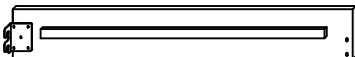
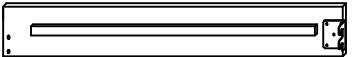
# ASSEMBLY INSTRUCTION

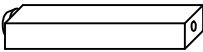
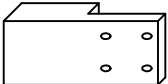
MODEL: SKU#1372-104,1372-105

PARTS LIST			
NO.		DESCRIPTION	QTY
D		FOOTBOARD	1
E		SIDE RAIL (i) - (E)	2
F		SIDE RAIL (ii) - (F)	2
G		BED SLAT	4
H		BED SLAT SUPPORT LEG	4
I		SIDE RAIL SUPPORT LEG	2
J		POWER ADAPTER	1

# ASSEMBLY INSTRUCTION

MODEL: SKU#1372-104,1372-105

## Step 1.

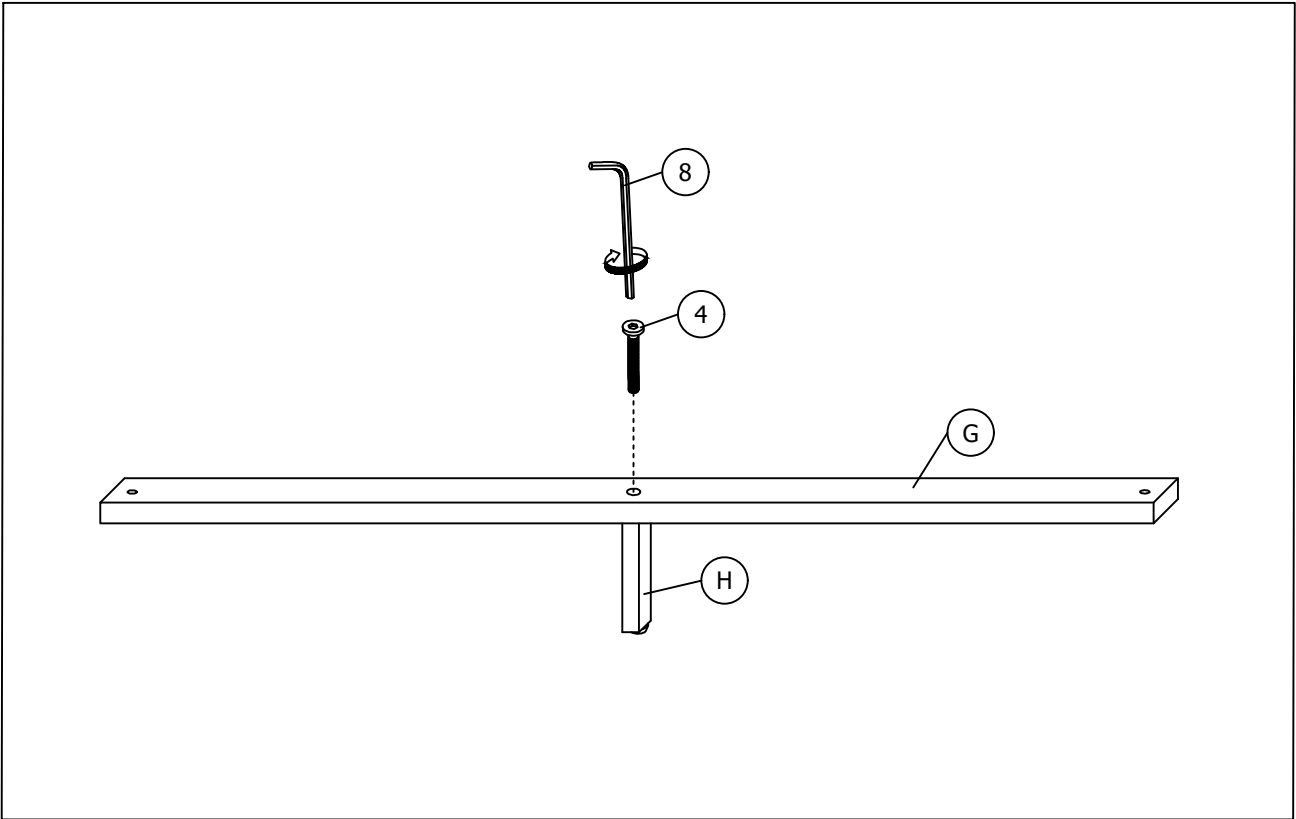

## Step 2.

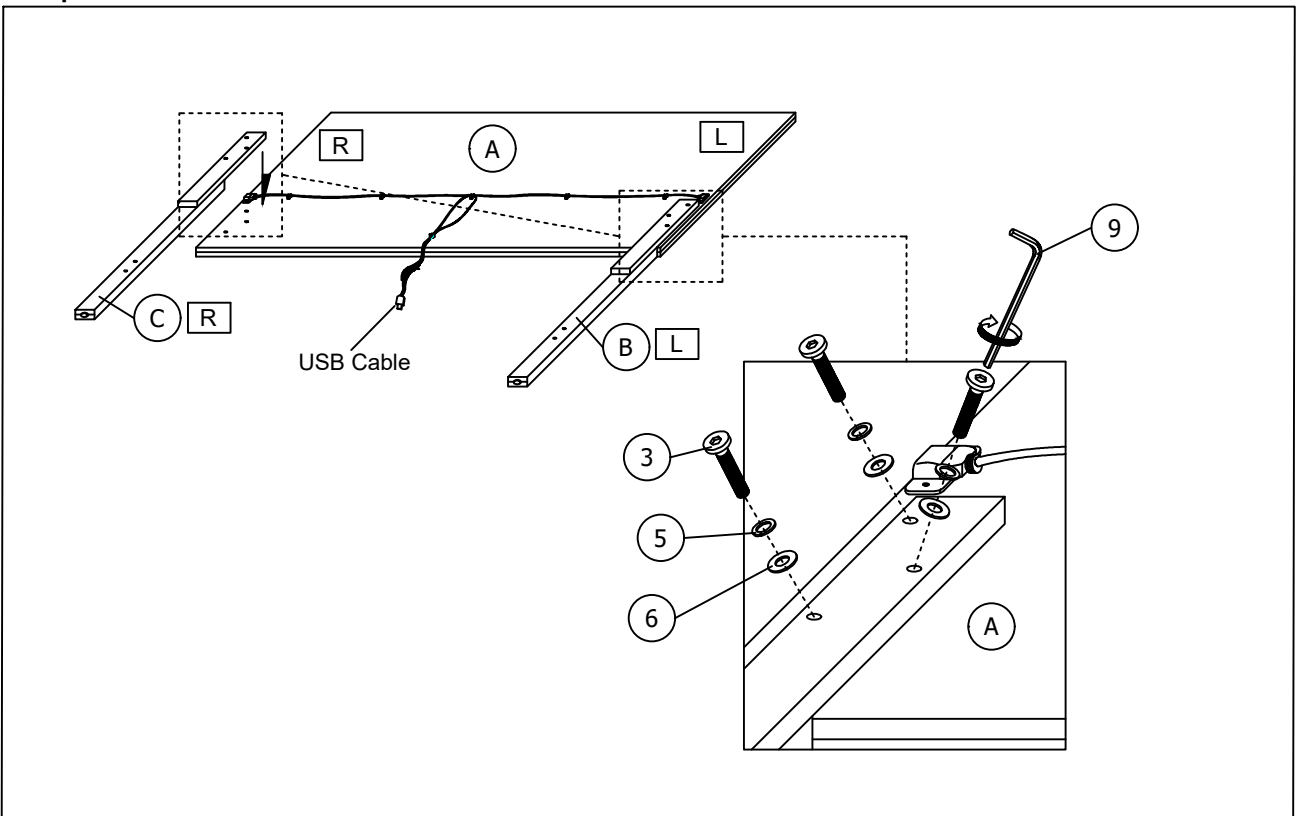

# ASSEMBLY INSTRUCTION

MODEL: SKU#1372-104,1372-105

## Step 3.

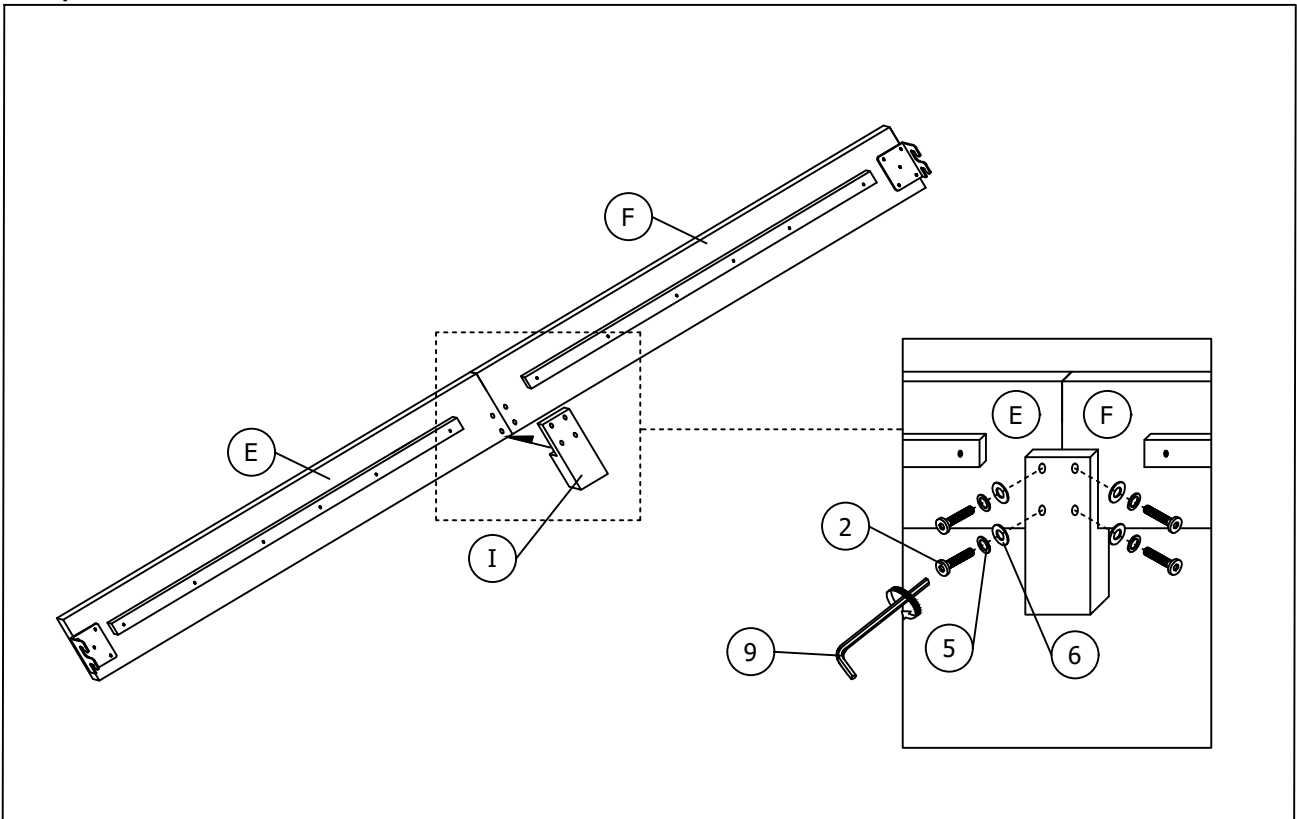

## Step 4.

- Step 4.1 : Insert but do not tighten item (1).
- Step 4.2 : Combine item (E)&(F) to item (B),(C) and (D).
- Step 4.3 : Tighten item (1).

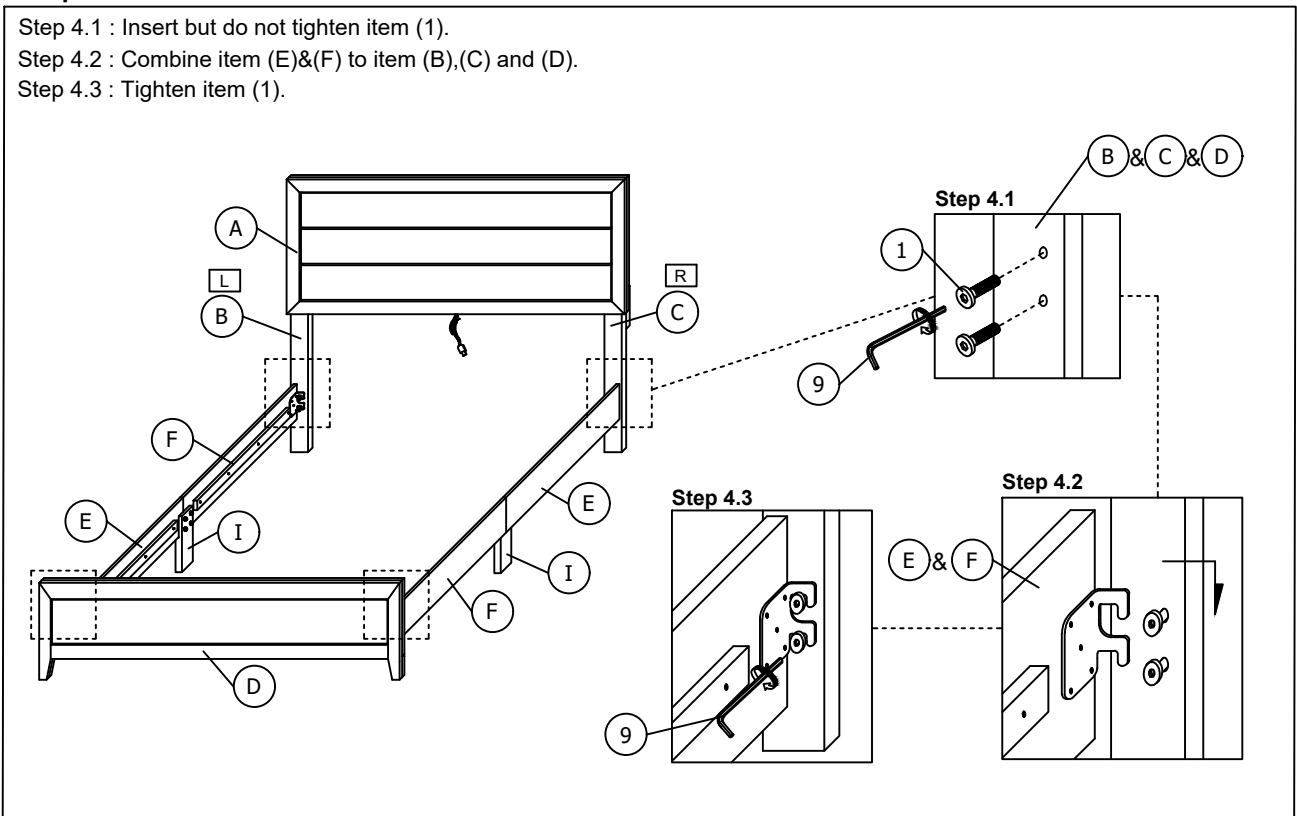

# ASSEMBLY INSTRUCTION

MODEL: SKU#1372-104,1372-105

## Step 5.

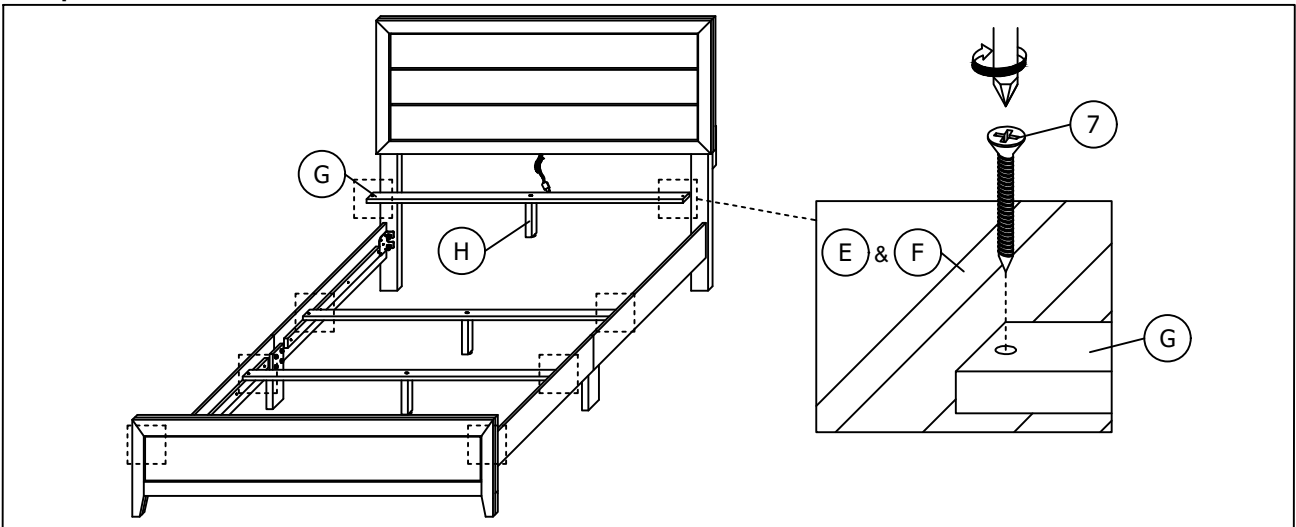

## Step 6.

