



ASSEMBLY INSTRUCTIONS



MODEL#: 1284-510 HARTFORD SLAT BACK SIDE CHAIR (V#12600BHTW1)

**NOTE: KEEP THIS DOCUMENT FOR REFERENCE IN CASE PARTS ARE NEEDED
DO NOT TIGHTEN SCREWS UNTIL COMPLETELY ASSEMBLED!!**

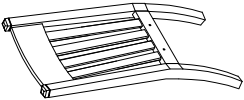
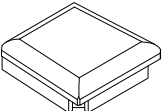
Care Instructions:

Please wipe clean using a non-abrasive mild soap and warm water.

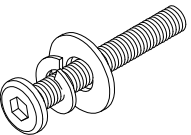
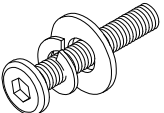
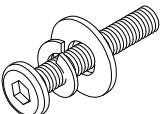
NO		PARTS LIST	Q'TY
A		CHAIR BACK	1 PC
B		CHAIR SEAT	1 PC
C		LEG	2 PCS

NO		HARDWARE LIST	Q'TY	
1		Long Bolt	Ø5/16"x3-1/4"	4 PCS
		Lock Washer	Ø5/16"	4 PCS
		Flat Washer	Ø5/16"x19Dx1.5mm	4 PCS
2		Short Bolt	Ø5/16"x2"	4 PCS
		Lock Washer	Ø5/16"	4 PCS
		Flat Washer	Ø5/16"x19Dx1.5mm	4 PCS
3		Short Bolt	Ø1/4"x1-1/2"	2 PCS
		Lock Washer	Ø1/4"	2 PCS
		Flat Washer	Ø1/4"x19Dx2mm	2 PCS
4		Allen Wrench	3"x4mm	1 PC

ASSEMBLY INSTRUCTIONS

MODEL#: 1284-510 HARTFORD SLAT BACK SIDE CHAIR (V#12600BHTW1)

NOTE: KEEP THIS DOCUMENT FOR REFERENCE IN CASE PARTS ARE NEEDED

DO NOT TIGHTEN SCREWS UNTIL COMPLETELY ASSEMBLED!!

STEP 1

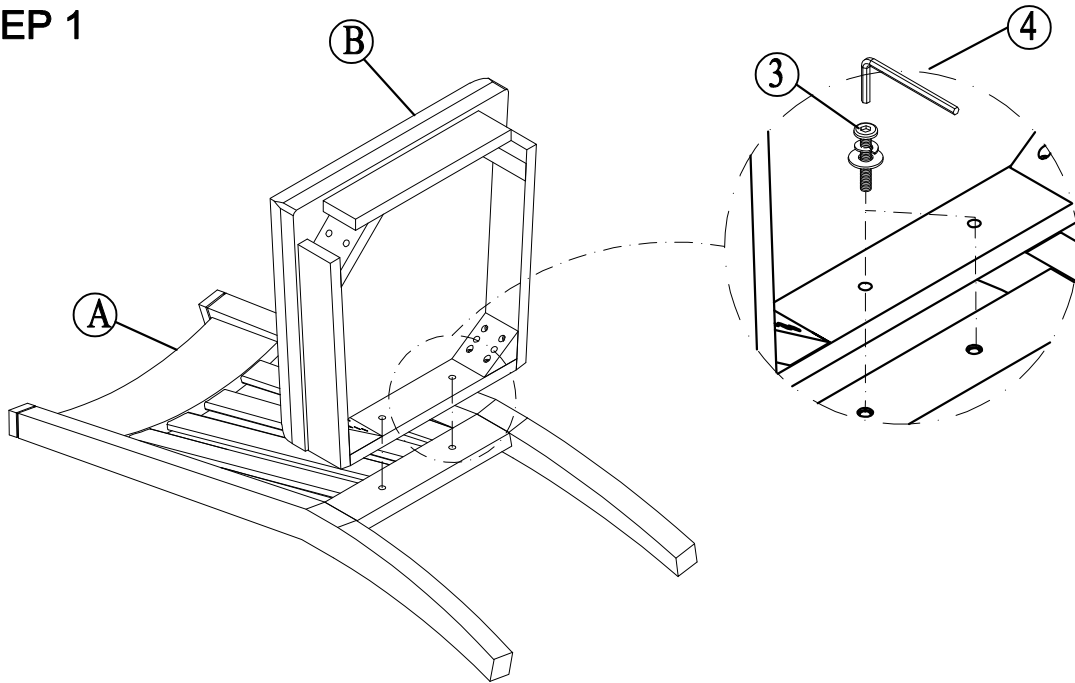

STEP 2

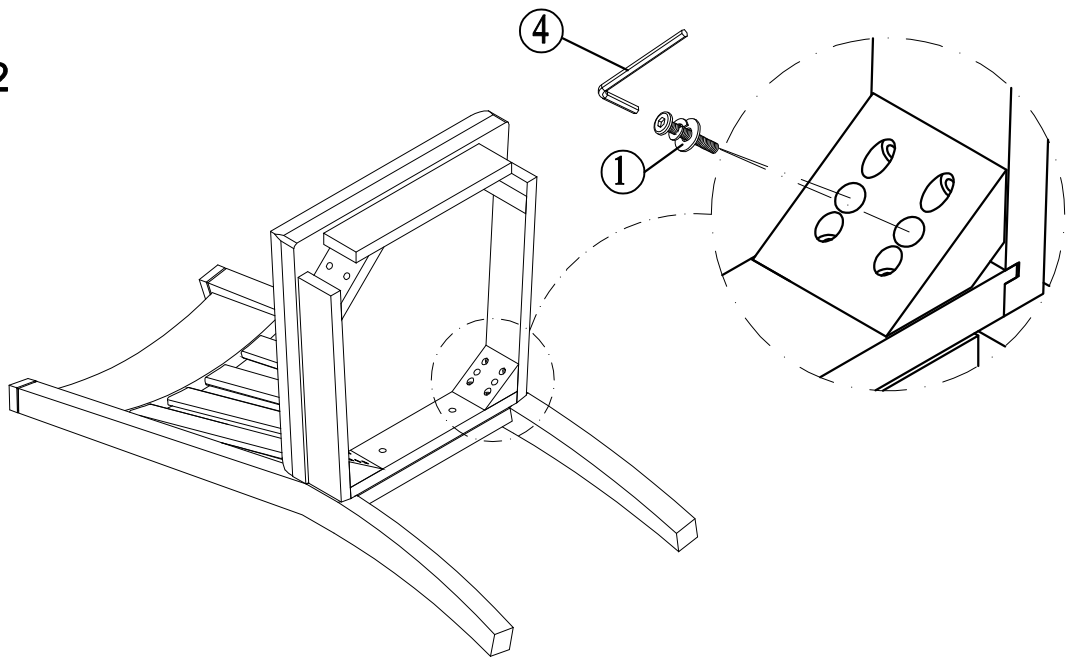

ASSEMBLY INSTRUCTIONS

MODEL#: 1284-510 HARTFORD SLAT BACK SIDE CHAIR (V#12600BHTW1)

**NOTE: KEEP THIS DOCUMENT FOR REFERENCE IN CASE PARTS ARE NEEDED
DO NOT TIGHTEN SCREWS UNTIL COMPLETELY ASSEMBLED!!**

STEP 3

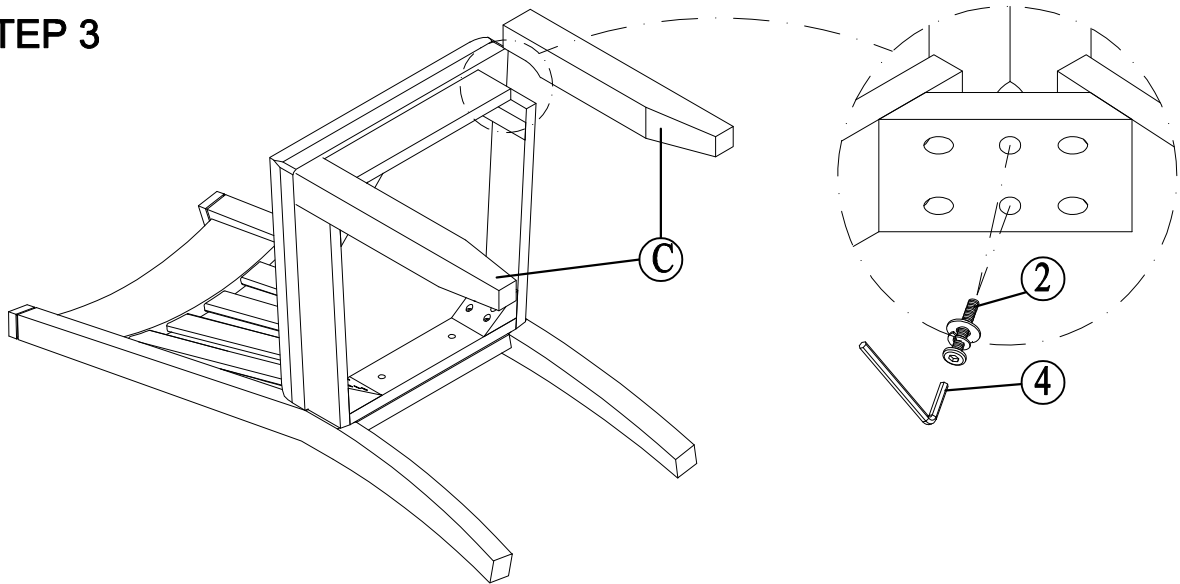

Assembly Completed

