

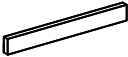



















# ASSEMBLY INSTRUCTIONS

MODEL : #1182DS-105HQN / #1182DS-105FQRL  
(V#12600CF SB1)

**NOTE : THIS ITEM NOT RECOMMENDED FOR COMMERCIAL USE  
KEEP THIS DOCUMENT FOR REFERENCE IN CASE PARTS ARE NEEDED**

**DO NOT TIGHTEN SCREWS UNTIL COMPLETELY ASSEMBLED !!**

NO		DESCRIPTION	QTY
A		Headboard	1pc
B		Footboard	1pc
C		Side Rail	2pcs
D		Legs	4pcs
E		Center Rail	1pc
F		Support Legs	2pcs
G		Stiffener Slat	2pcs
H		LVL Slat	28pcs
I		Side Wing	2pcs

NO		DESCRIPTION	QTY
1		JCBB M8 x 20	8pcs
2		JCBC M6 x 40	2 pcs
3		Wrench Key 65mm	1pc
4		Wrench Key 70mm	1pc
5		CSK Screw 25mm	2pcs
6		CSK Screw 32mm	6pcs
7		Adjuster	2pcs
8		Middle Holder	14pcs
9		End Holder	28pcs
10		JCBC M6 x 50	4 pcs
11		Spring Washers	4 pcs
12		Flat Washers	4 pcs

# ASSEMBLY INSTRUCTIONS

MODEL : #1182DS-105HQN / #1182DS-105FQRL  
(V#12600CF SB1)

## STEP 1 :

Unzip the black non-woven fabric on the back of headboard and take out the night stand. The side wings (Part I) are in the velcro pouch directly underneath the zipper pouch as second arrow shows.

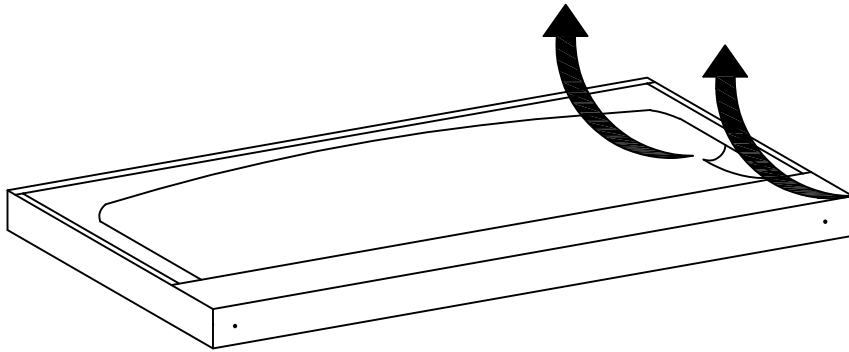

Attention: Re-zip the black non-woven fabric after you take out the parts.

## STEP 2 :

Tighten the side wing to headboard as shown. Attach the headboard and footboard with legs as shown.

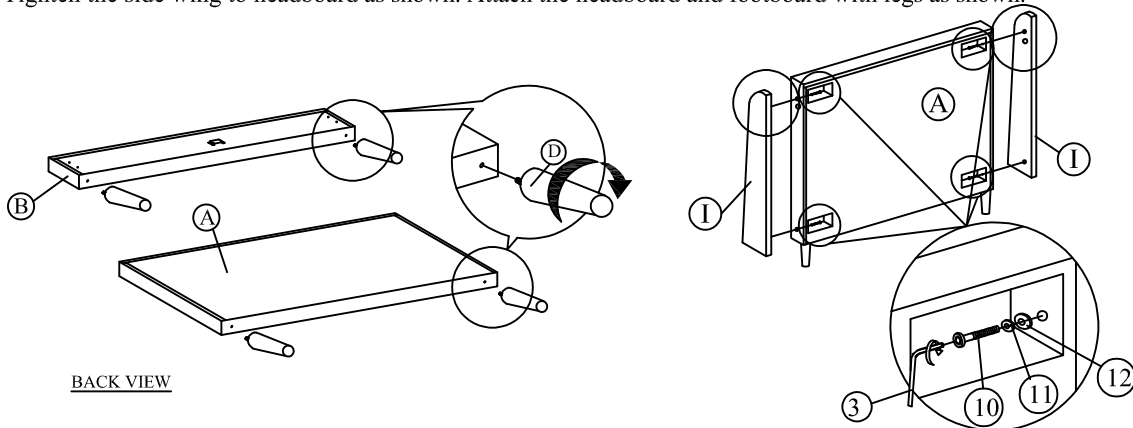

## STEP 3 :

Attach side rail to footboard first follow by headboard by pushing the bracket down to fit it.

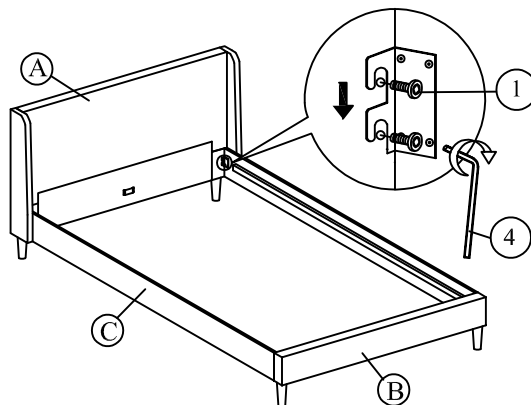

# ASSEMBLY INSTRUCTIONS

MODEL : #1182DS-105HQN / #1182DS-105FQRL  
(V#12600CF5B1)

## STEP 4 :

Attach the support legs to the center rail of the bed as shown.

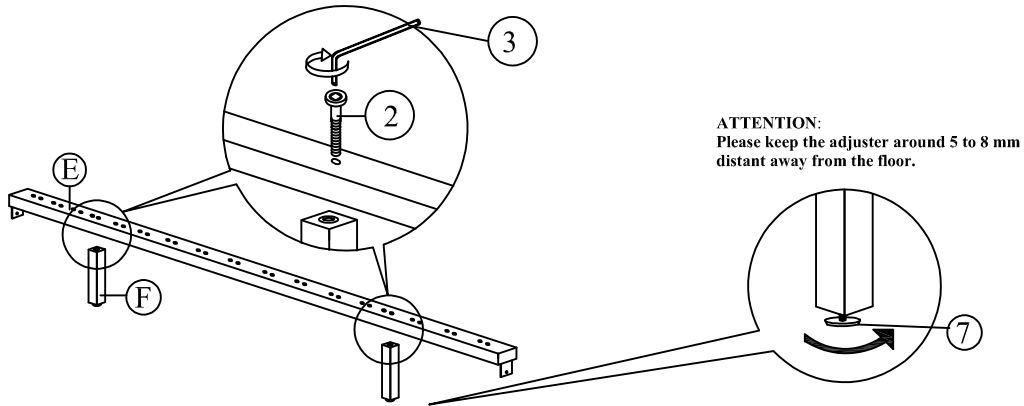

## STEP 5 :

Slide the center rail to the headboard and footboard . Tighten screws using screw driver (not included) to the headboard (A) and footboard (B).

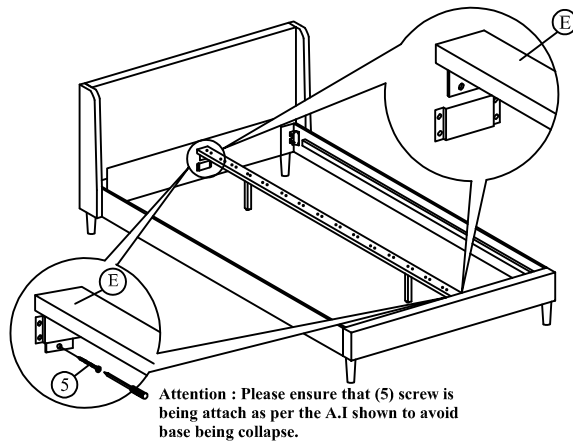

## STEP 6 :

Affix the stiffener slat to the side rail support wood and the center rail. Tighten all the 4 corner , follow by assembly of the slat holders with LVL slats as shown.

