

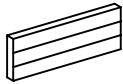









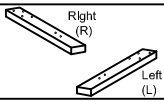

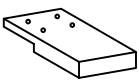
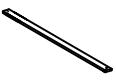

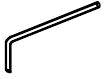
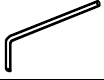

ASSEMBLY INSTRUCTIONS

MODEL : #1138DS-110 (V#12600CFSB1)

KEEP THIS DOCUMENT FOR REFERENCE IN CASE PARTS ARE NEEDED
DO NOT TIGHTEN SCREWS UNTIL COMPLETELY ASSEMBLED !!

| NO | | DESCRIPTION | QTY |
|----|---|----------------|-------|
| A |  | Headboard | 1pc |
| B |  | Footboard | 1pc |
| C |  | Side Rail | 4pcs |
| D |  | Headboard Legs | 2pcs |
| E |  | Support Legs | 8pcs |
| F |  | Legs | 2pcs |
| G |  | Side Rail Legs | 2pcs |
| H |  | Center Rail | 4pcs |
| I |  | Slat | 14pcs |

| NO | | DESCRIPTION | QTY |
|----|--|-----------------|-------|
| 1 |  | JCBB M8 x 20 | 8pcs |
| 2 |  | JCBC M6 x 30 | 8pcs |
| 3 |  | JCBC M6 x 50 | 6pcs |
| 4 |  | JCBC M6 x 60 | 8pcs |
| 5 |  | Wrench Key 65mm | 1pc |
| 6 |  | Wrench Key 70mm | 1pc |
| 7 |  | CSK Screw 32mm | 28pcs |
| 8 |  | Spring Washers | 6pcs |
| 9 |  | Flat Washers | 8pcs |
| 10 |  | Adjuster | 8pcs |
| 11 |  | USB Port | 1set |
| 12 |  | CSK Screw 16mm | 4pcs |

ASSEMBLY INSTRUCTIONS

MODEL : #1138DS-110 (V#12600CF SB1)

STEP 1 :

Unzip the black non-woven fabric on the back of headboard and take out the part.

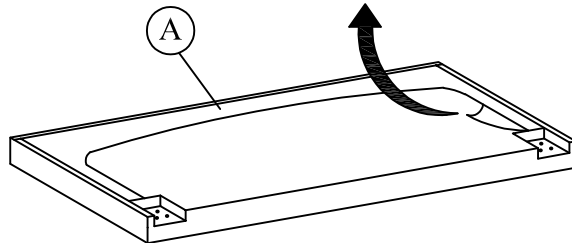

Attention: Zip the black non-woven fabric after take out the parts !!

BACK VIEW

STEP 2 :

Fix the headboard (A) and headboard legs (D), Then fix the footboard (B) with footboard legs (F) as shown.

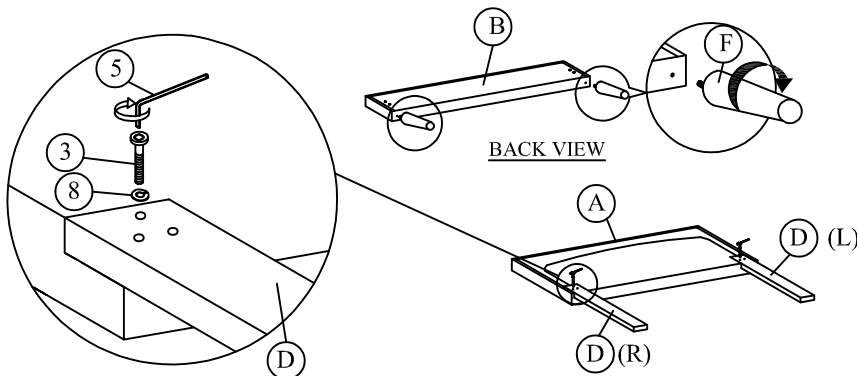

STEP 3 :

Attach the JCBB Bolt (1) to the headboard and footboard .

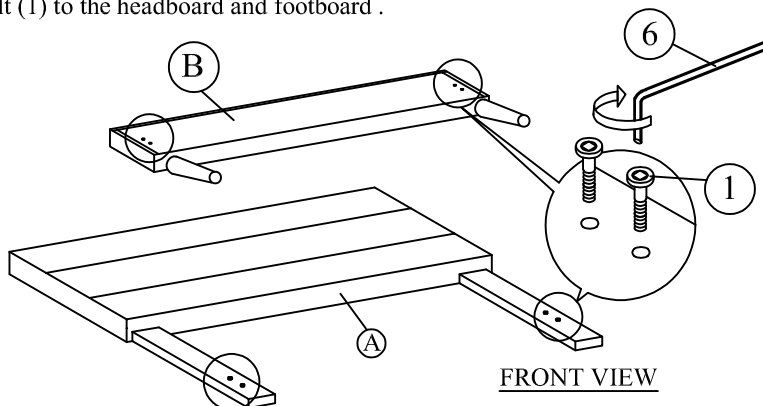

ASSEMBLY INSTRUCTIONS

MODEL : #1138DS-110 (V#12600CFSB1)

STEP 4 :

Attach the side rail leg (G) to the side rail (C).

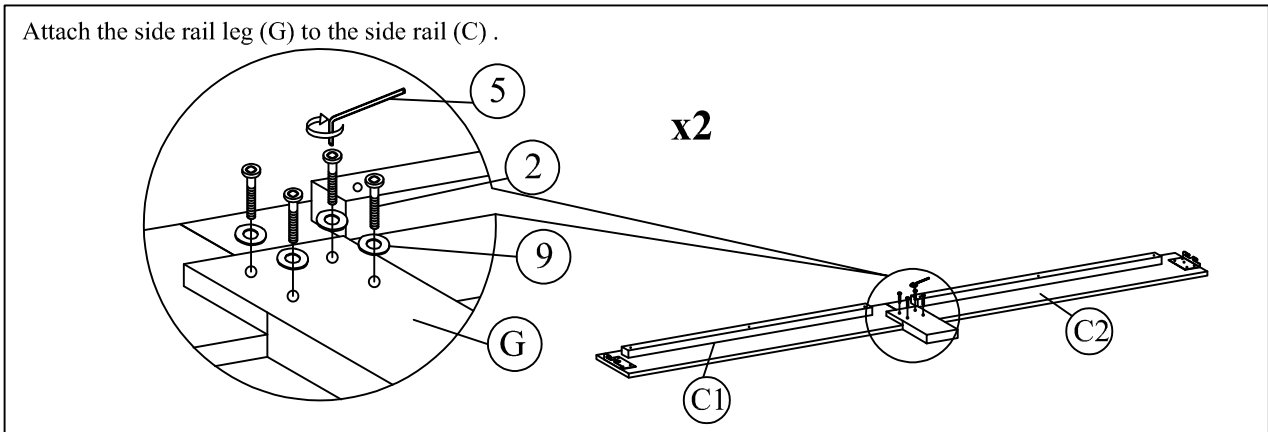

STEP 5 :

Attach side rail (C) to headboard (A) and footboard (B) by pushing the bracket down to fit it.

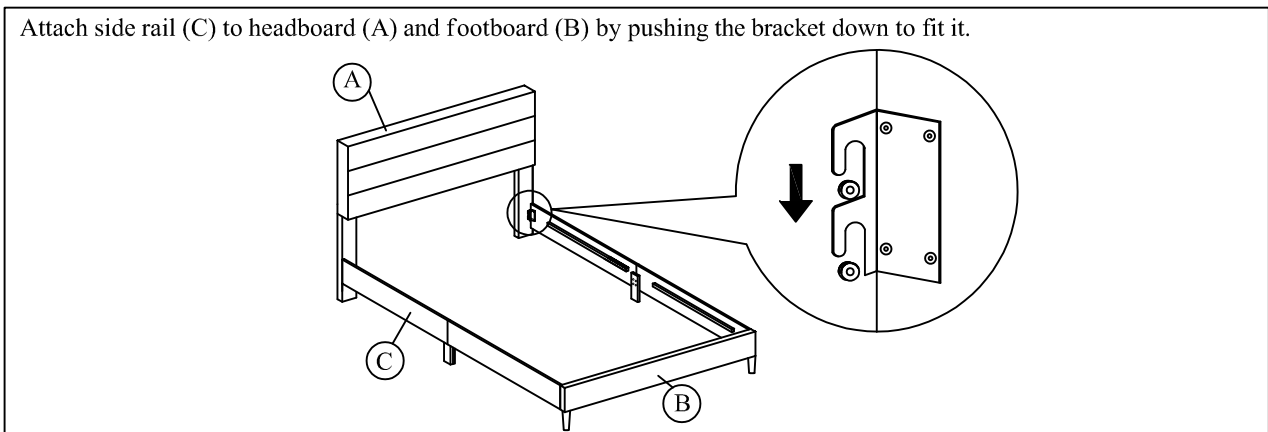

STEP 6 :

Attach the support legs (E) to the center rail (H) and slats (I) of the bed as shown.

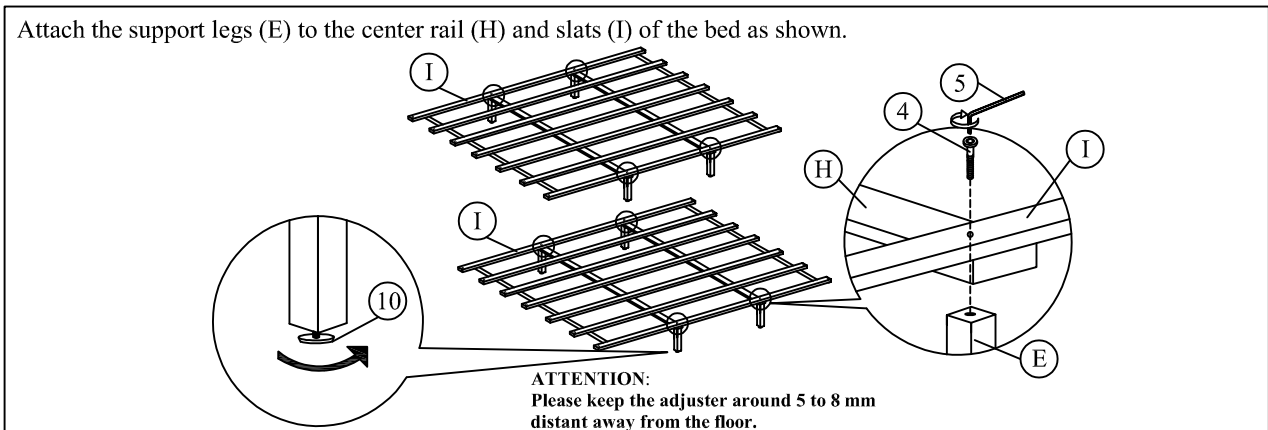

ASSEMBLY INSTRUCTIONS

MODEL : #1138DS-110 (V#12600CFSB1)

STEP 7 :

Affix the Slat (I) to the side rail support wood. Tighten all the 4 corner. Tighten the slats with CSK screw.

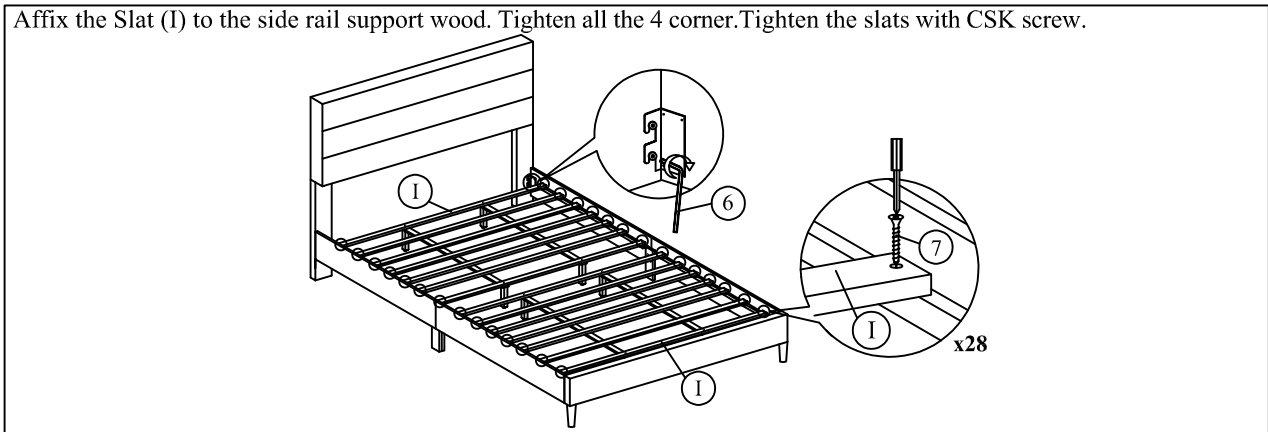

STEP 8 :

Attach the USB at the back of the headboard (Screw in at the marking provided).

