

ASSEMBLY INSTRUCTIONS

















V#12600JG1 1OF2

MODEL:#1118-105 ELLIS QUEEN SCROLL METAL BIAB

MODEL:#1118-110 ELLIS KING SCROLL METAL BIAB

KEEP THIS DOCUMENT FOR REFERENCE IN CASE PARTS ARE NEEDED

DO NOT TIGHTEN SCREWS UNTIL COMPLETELY ASSEMBLED!!

NO.		DESCRIPTION	QTY	NO.		DESCRIPTION	QTY
A		HEADBOARD QUEEN&KING SIZE	1PC	J		BOLTS M6X40MM	18PCS
B		FOOTBOARD QUEEN&KING SIZE	1PC	K		BOLTS M6X50MM	2PCS
C		EXTENSION LEG QUEEN&KING SIZE	2PCS	M		BOLTS M8X55MM	4PCS
L		SIDE RALL(LEFT) QUEEN&KING SIZE	2PCS	N		BOLTS M8X16MM	8PCS
R		SIDE RALL(RIGHT) QUEEN&KING SIZE	2PCS	O		M8	4PCS
D		CENTER RAIL	1PC	P		M6	10PCS
E		BRACKET (CENTER RAIL)	2PCS	Q		M8	8PCS
F		CROSS BAR(HEADBOARD)	1PC	S		M6	18PCS
G		METAL SLATS(FRAME)	4PCS	T		M8	2PCS
H		CENTER SUPPORT LEGS	8PCS	U		#4#10	2PCS
I		BOLTS M6X16MM	4PCS	V		#5#13	2PCS

STEP1

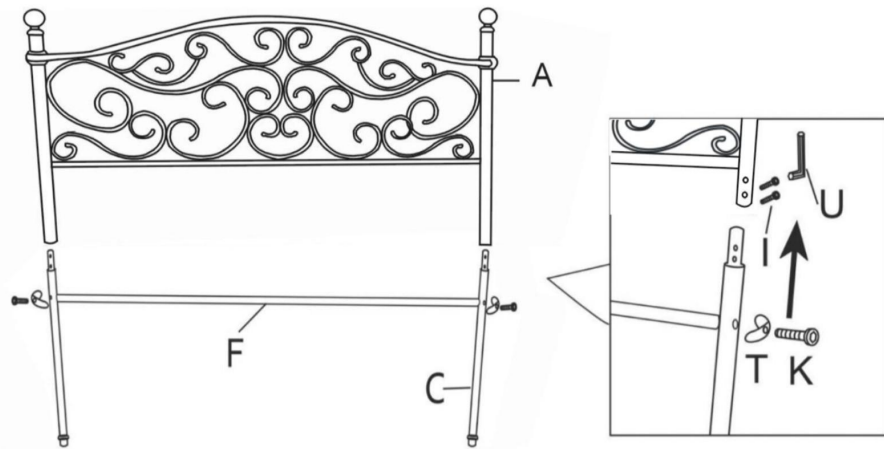

STEP2

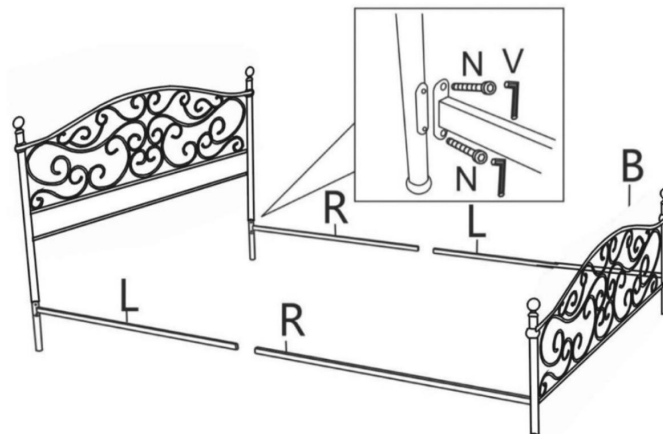

ASSEMBLY INSTRUCTIONS

V#12600JG1 2OF2

MODEL:#1118-105 ELLIS QUEEN SCROLL METAL BIAB

MODEL:#1118-110 ELLIS KING SCROLL METAL BIAB

KEEP THIS DOCUMENT FOR REFERENCE IN CASE PARTS ARE NEEDED

DO NOT TIGHTEN SCREWS UNTIL COMPLETELY ASSEMBLED!!

STEP3

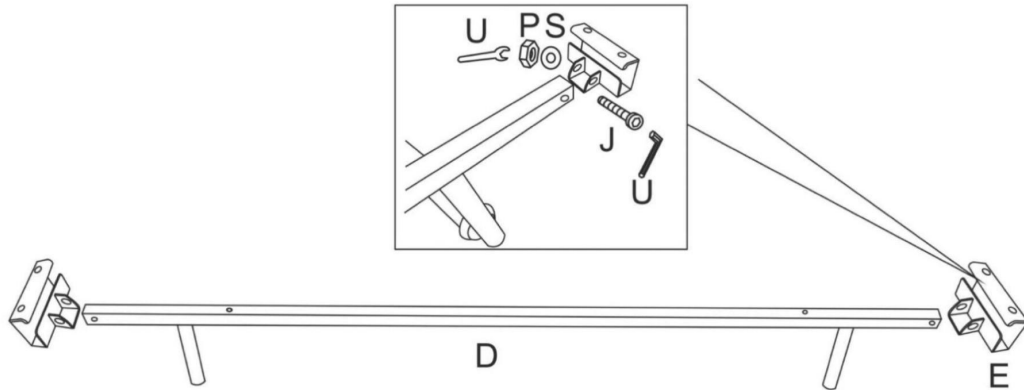

STEP4

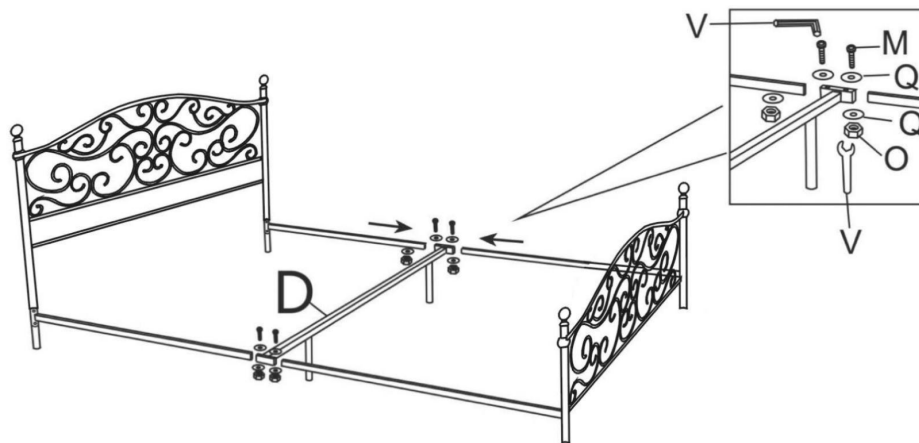

STEP5

