

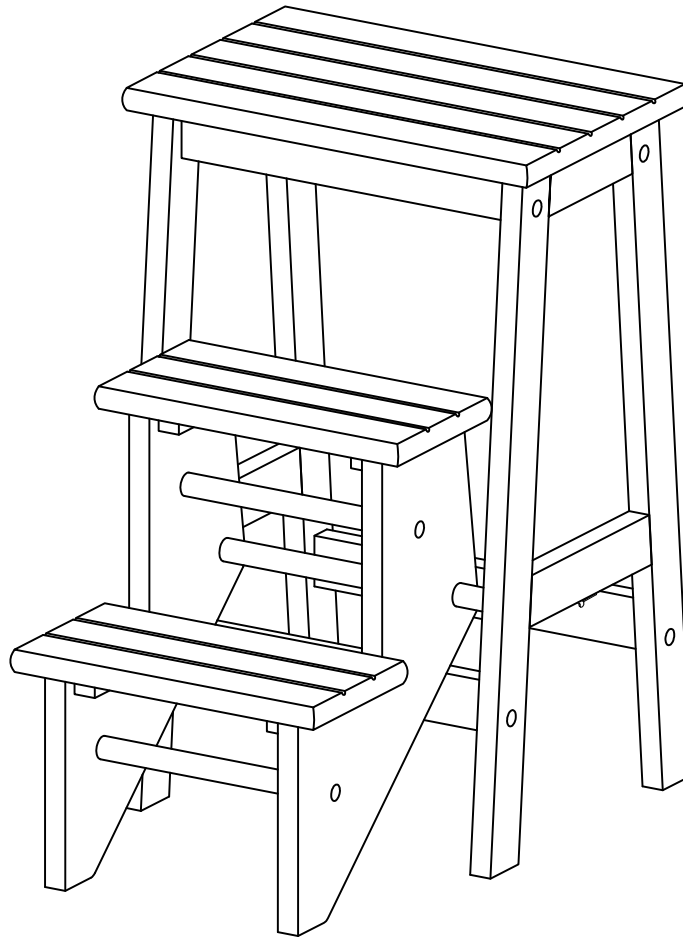

Boraam Industries

ASSEMBLY INSTRUCTIONS

SKU: 36324,36824,36224,36124,36724,36624 | STEP STOOL



Have questions about assembling your item?



Items or parts damaged?



Missing a part?

We're here to help! (Monday-Friday from 9am-5pm CST)



847-949-6300
877-267-2261



customerservice@
boraamindustries.com



www.boraamindustries.com

Phillips
Screwdriver
(Not provided)

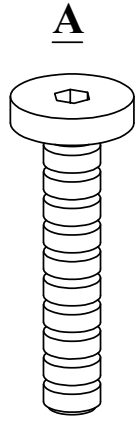

M6*35
8 PCS

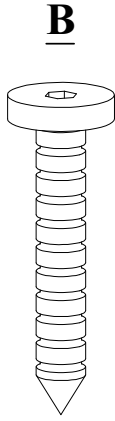

M6*30
12 PCS

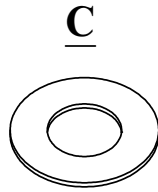

Flat Washer
8 PCS

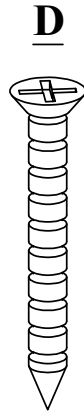

M4*30
2 PCS



Wood Button
12 PCS

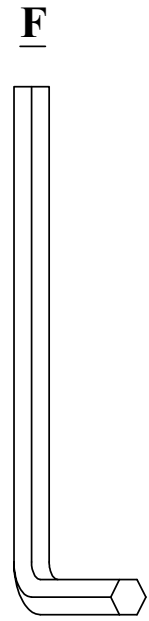

Allen Wrench
1 PC

①

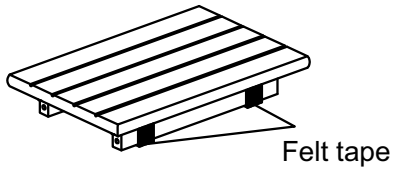

Felt tape

② LEFT

③ RIGHT



Metal latch

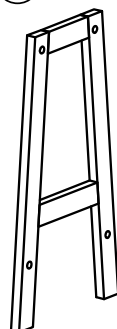
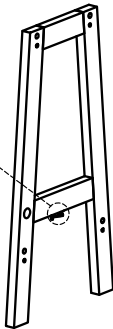

④a (with FELT TAPE)

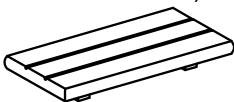

④b

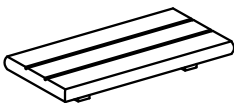

⑤ LEFT

⑥ RIGHT

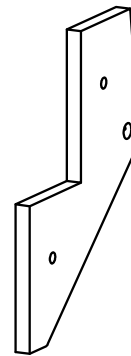
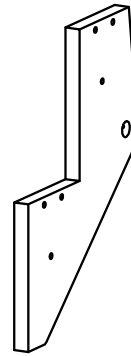

⑦

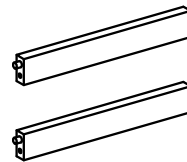

⑧

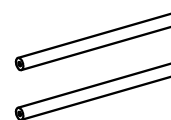

⑨

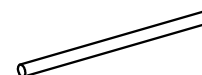

01

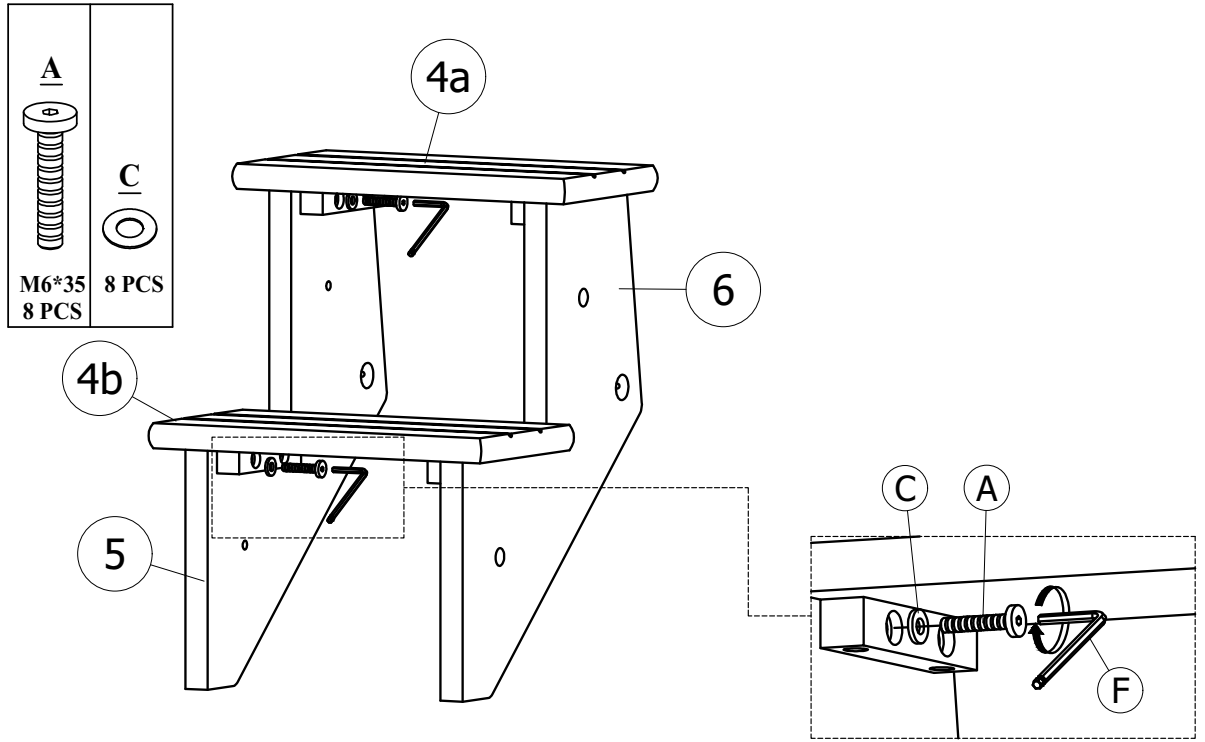

DO NOT TIGHTEN BOLT COMPLETELY.

02

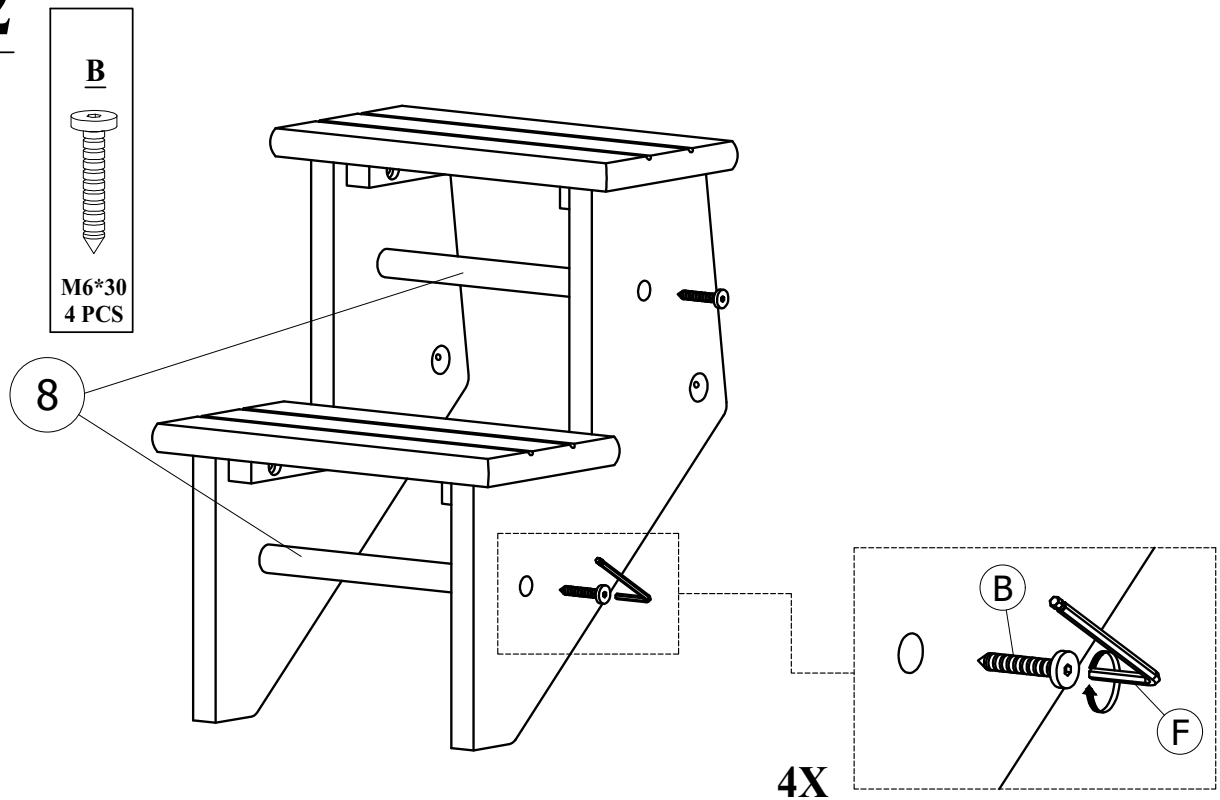

DO NOT TIGHTEN SCREW COMPLETELY.

03

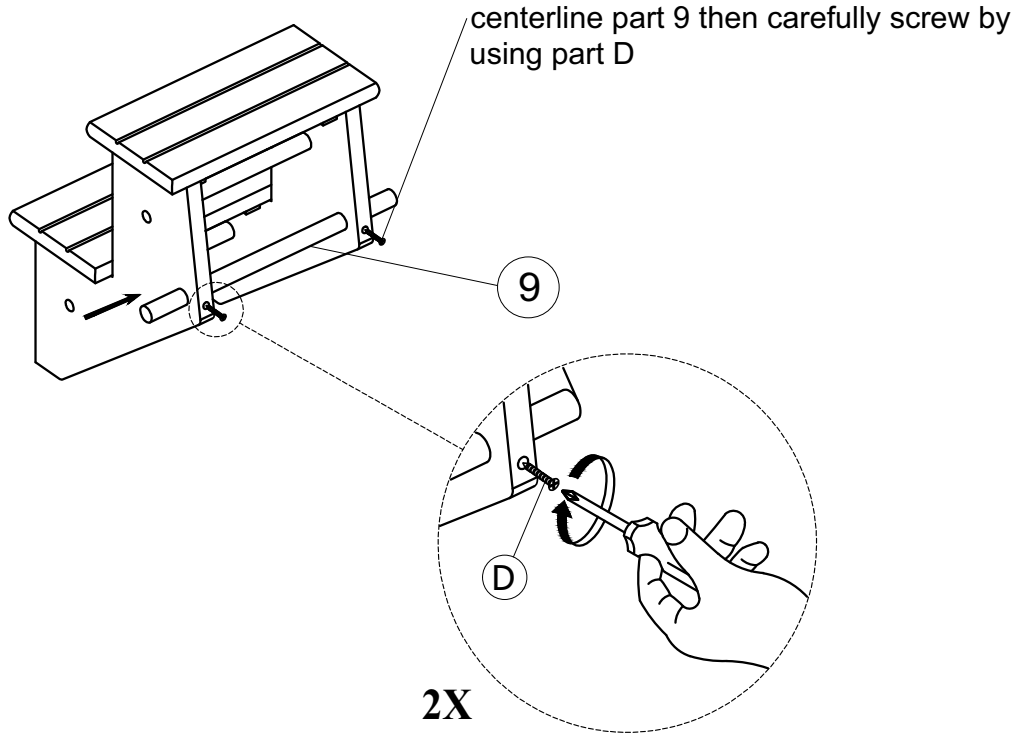
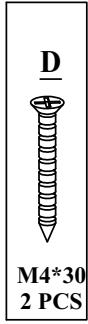

TIGHTEN SCREW COMPLETELY.

04

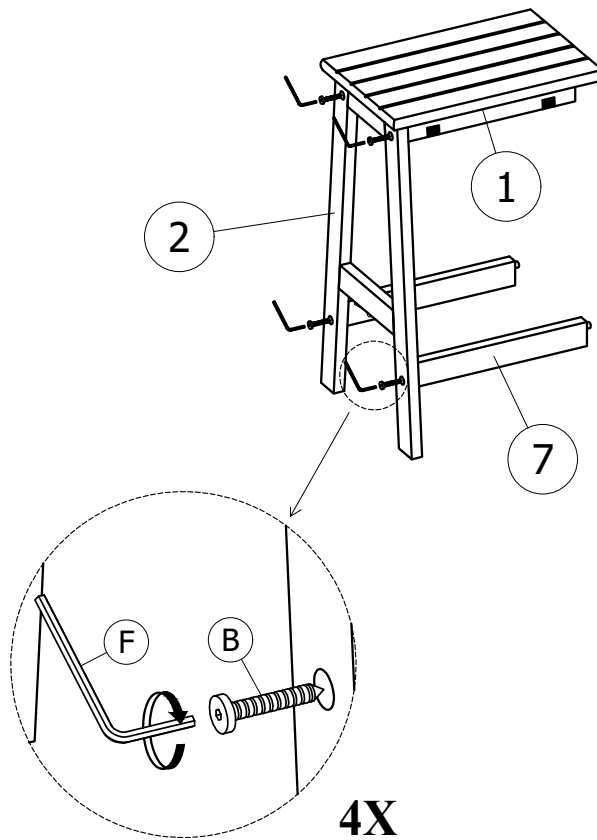

TIGHTEN SCREW COMPLETELY.

05

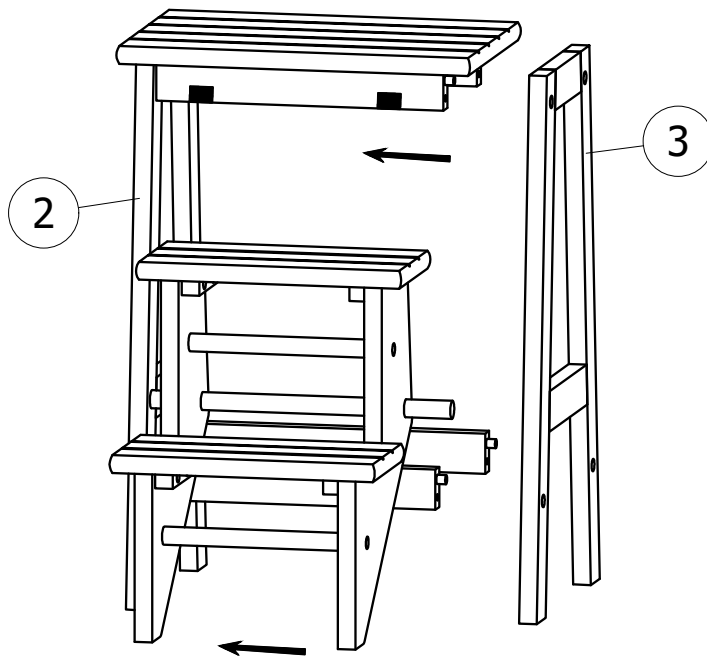
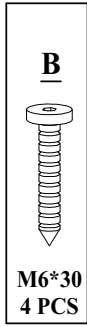

06

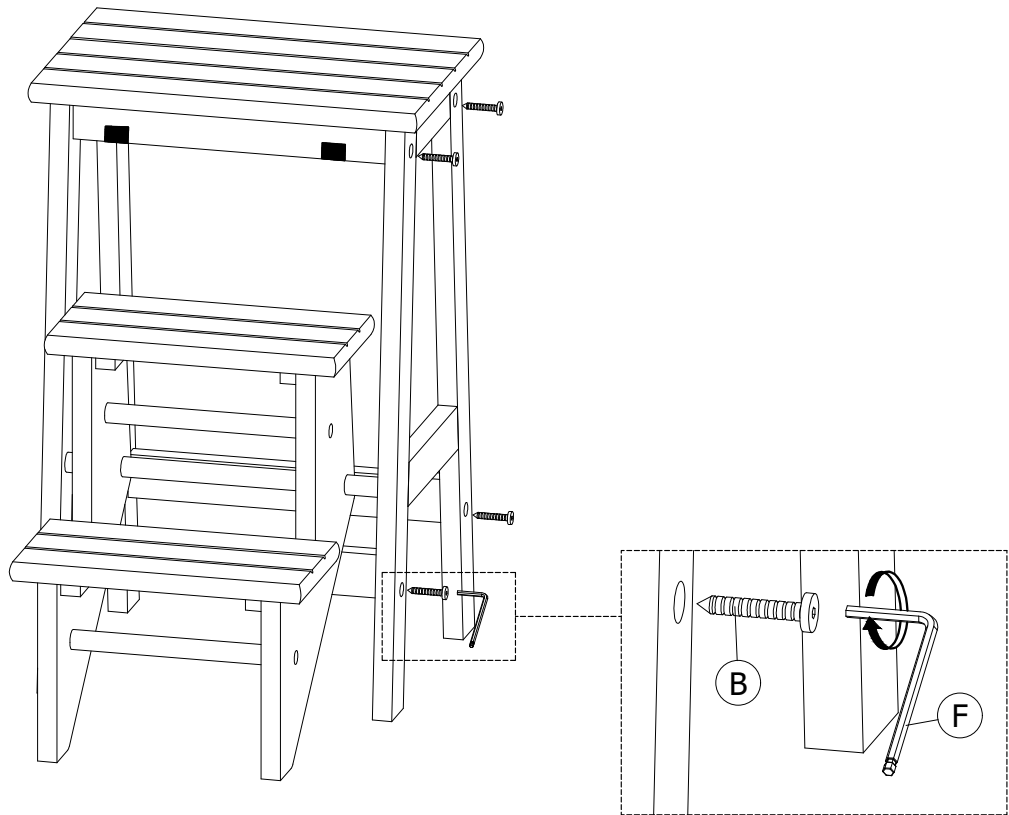
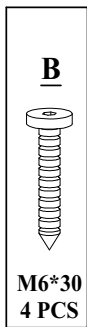

TIGHTEN BOLT AND SCREW COMPLETELY.

847-949-6300 | 877-267-2261 | customerservice@boraamindustries.com

07

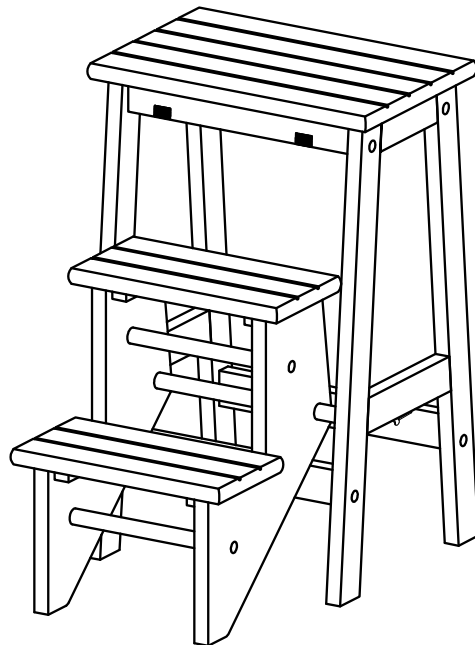
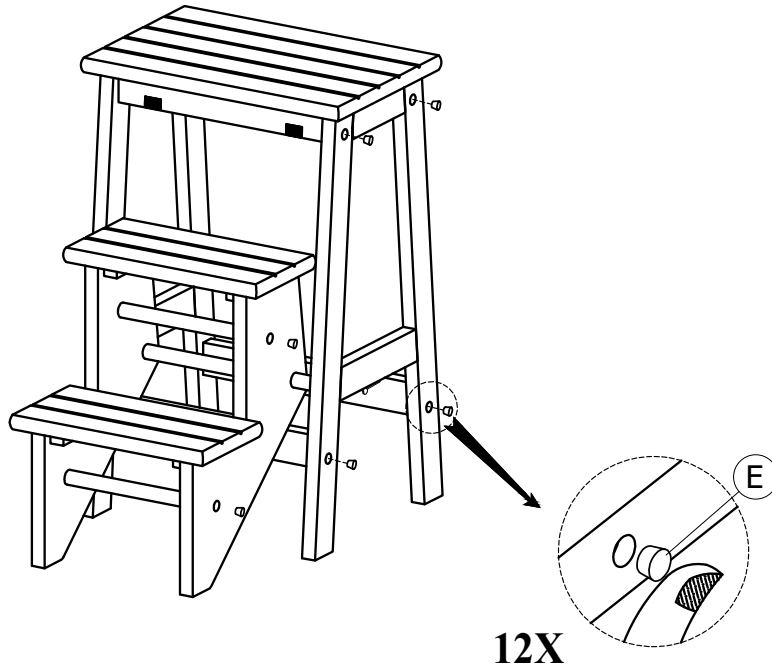
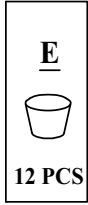

BE SURE TO CHECK ALL BOLTS ARE SECURELY TIGHTENED PRIOR USING THIS STOOL

847-949-6300 | 877-267-2261 | customerservice@boraamindustries.com