

SW 3513 3 SEATER (WITH SUPPORT LEG)

1.

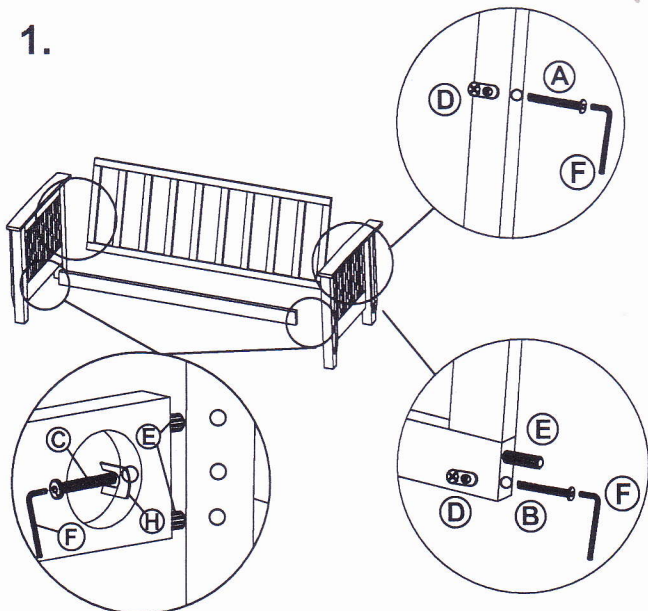

Attach the backrest (P1) and front rail (P2) between the handle (P3). You will need to use hardware:

- A = 2 pcs
- B = 2 pcs
- C = 2 pcs
- D = 4 pcs
- E = 6 pcs
- F = 1 pcs
- H = 2 pcs

WARNING!!

- Remove hardware from box and sort by size.
- Please check to see that hardware and parts are present prior start of assembly.
- Please follow attached instruction in the same sequence numbered to ensure fast and easy assembly.
- Do not use this sofa if any part is broken, torn or missing.
- The assembly of this product requires two people.
- Do not use any power tools as this may damage the frame and will invalidate any claim.
- Please do not tighten the unit until fully set up for the easy of parts installation.

PART LIST

P1		Backrest	=	1pc
P2		Front Rail	=	1pc
P3		Handle	=	2pcs
P4		Seat	=	2pcs
P5		Seat with Centre Rail	=	1pc
P6		Support leg	=	1pc

2.

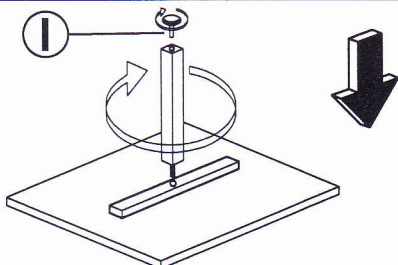

Attach the support leg (P6) to the seat with centre rail (P5). Fix the adjuster (I) to the bottom of the support leg. You will need to use hardware :

- I = 1 pcs

3.

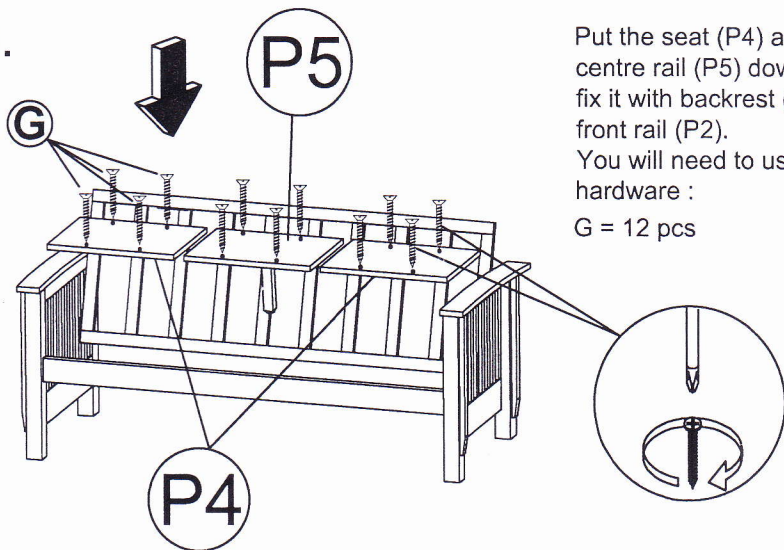

Put the seat (P4) and seat with centre rail (P5) down and fix it with backrest (P1) and front rail (P2). You will need to use hardware :

- G = 12 pcs

HARDWARE LIST

A		M6 X 110MM JCBC	=	2pcs
B		M6 X 60MM JCBC	=	2pcs
C		M6 X 50MM JCBC	=	2pcs
D		BARREL NUT	=	4pcs
E		M8 X 35MM WOOD DOWEL	=	6pcs
F		ALLEN KEY M4	=	1pcs
G		M4 X 25MM SCREW	=	12pcs
H		U WASHER	=	2pcs
I		ADJUSTER	=	1pcs

4. FULLY SET UP

