

SW 3513 CHAIR

(This assembly method also apply to 2 seater and 3 seater)

1.

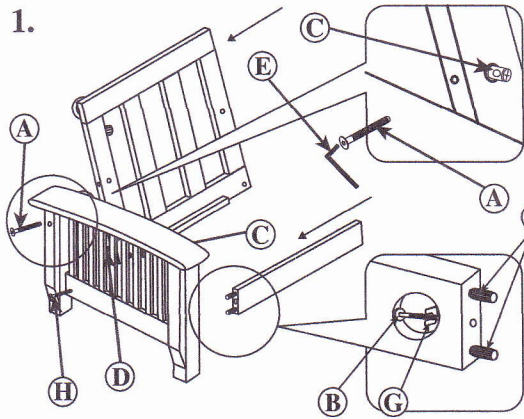

Attach the backrest (P1) and front rail (P2) between the handle (P3).

You will need to use hardware:

- A = 2pcs
- B = 2pcs
- C = 4pcs
- D = 6pcs
- E = 1pcs
- G = 2pcs
- H = 2pcs

2.

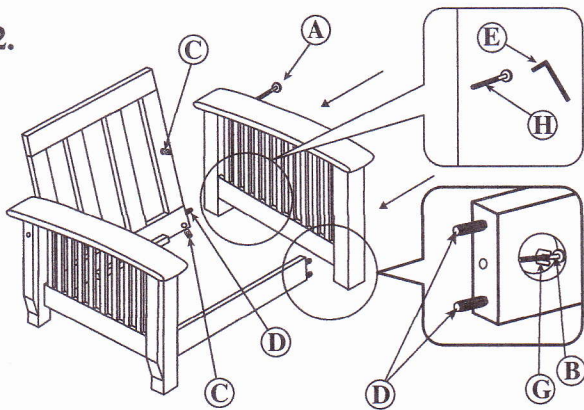

3.

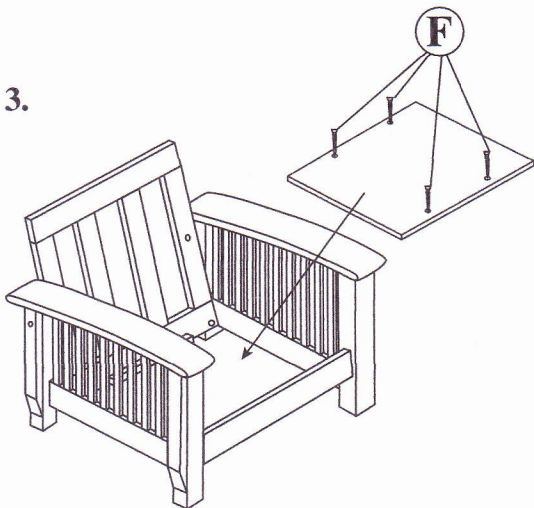

Put the seat panel (P4) down and fix it with backrest (P1) and front rail (P2).

You will need to use hardware:

- F = 4pcs (1 seater)
- 8pcs (2 seater)
- 12pcs (3 seater)

WARNING!!

- Remove hardware from box and sort by size.
- Please check to see that hardware and parts are present prior start of assembly.
- Please follow attached instruction in the same sequence numbered to ensure fast and easy assembly.
- Do not use this sofa if any part is broken, torn or missing.
- The assembly of this product requires two people.
- Do not use any power tools as this may damage the frame and will invalidate any claim.
- Please do not tighten the unit until fully set up for the easy of parts installation.

PART LIST

P1		Backrest	= 1pcs
P2		Front Rail	= 1pcs
P3		Handle	= 2pcs
P4		Seat Panel	1S = 1pcs 2S = 2pcs 3S = 3pcs

HARDWARE LIST

A		M6 x 110mm JCBC	2pcs
B		M6 x 50mm JCBC	2pcs
C		BARREL NUT	4pcs
D		Ø8 x 35mm WOOD DOWEL	6pcs
E		ALLEN KEY M4	1pcs
F		WOOD SCREW M4x 25 1 SEATER 2 SEATER 3 SEATER 4pcs 8pcs 12pcs	
G		U WASHER M6 x 25	2pcs
H		M6 x 60mm JCBC	2pcs

FULLY SET UP

