

ASSEMBLY INSTRUCTION

MODEL: SW 3513

When doing assembly, kindly follow this Assembly Instruction step by step. Also, please do NOT tighten-up screws until the chair is set up. **BALANCE**

HARDWARE LIST		
NO	DESCRIPTION	QTY
A	M6X 110MM ICBC	2pcs
B	M6X 50MM ICBC	2pcs
C	BARREL NUT	4pcs
D	8X 35MM WOOD DOVEL	6pcs
E	ALLEN KEY	1pcs
F	M4 X 25MM SCREW	
	1 SEATER	4pcs
	2SEATER	8pcs
	3SEATER	12pcs
G	U-WASHER	2 pcs
H	M6X 60MM ICBC	2 pcs

STEP 3

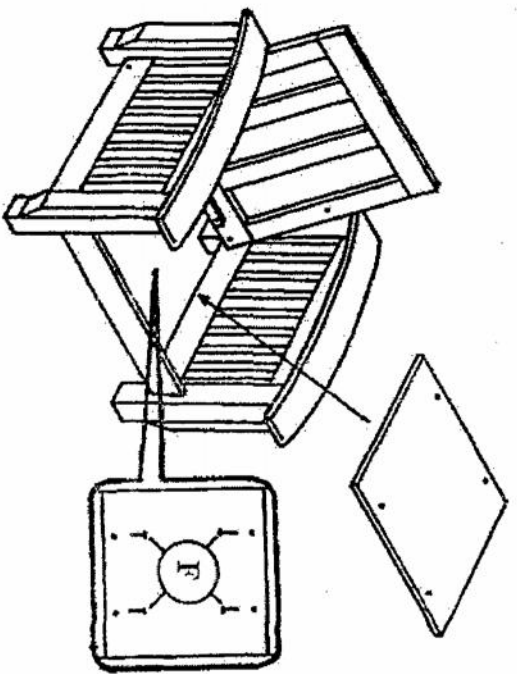

STEP 1

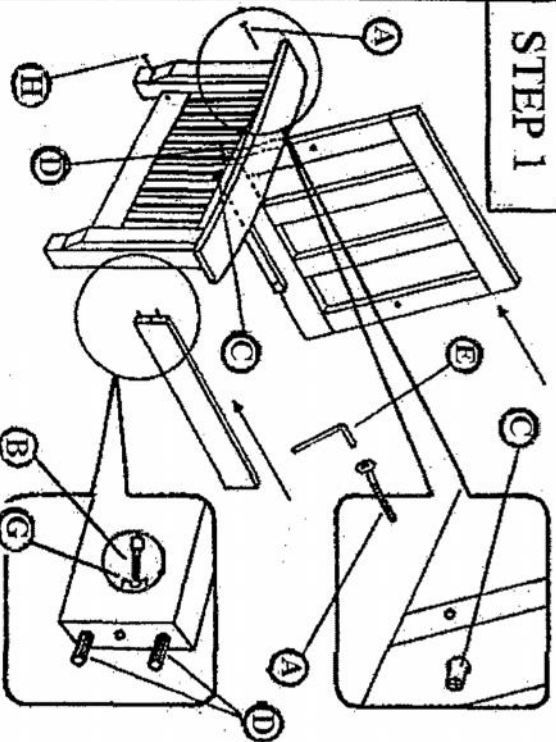

STEP 2

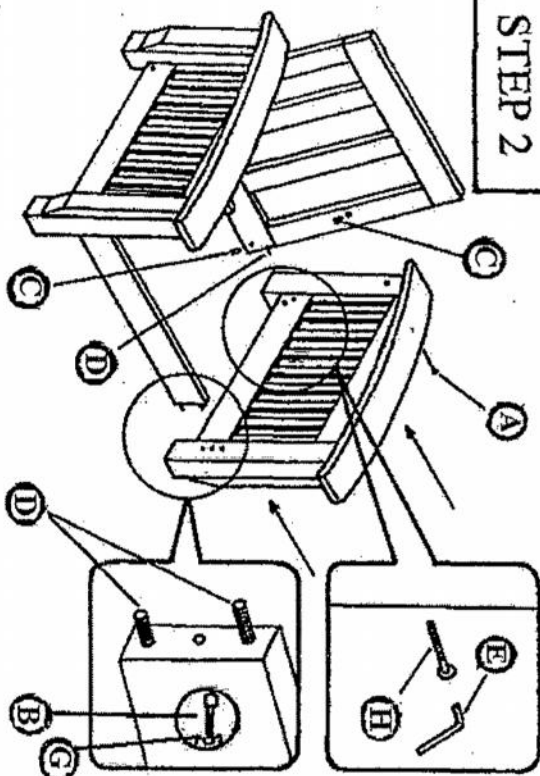

FULLY SET UP

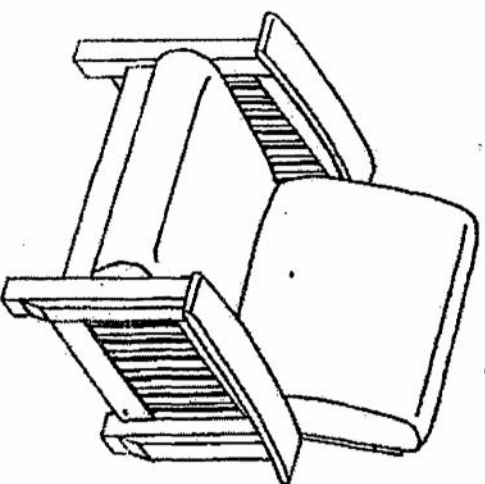

ASSEMBLY INSTRUCTION

MODEL: SW 3513 TABLE

When doing assembly, kindly follow this Assembly Instruction step by step. Also, please do NOT tighten-up screws until the table is set up **BALANCE**

HARDWARE LIST		QTY
NO	DESCRIPTION	
A	M6X 50MM JOBC	4pcs
B	BARREL NUT	4pcs
C	8X 35MM WOOD DOWEL	4pcs
D	ALLEN KEY	1pcs
E	M4X 25MM SCREW	4pcs

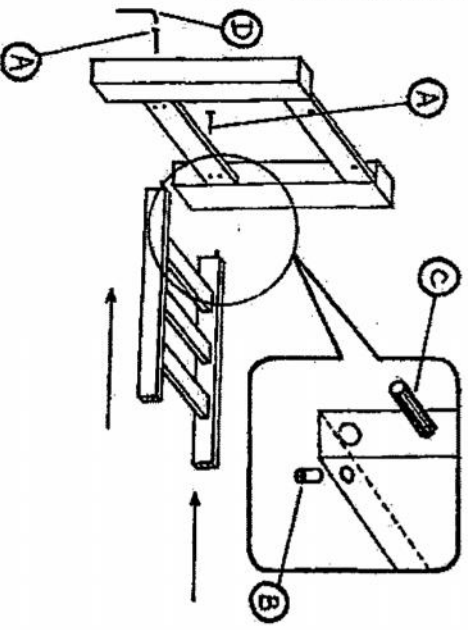

STEP 1

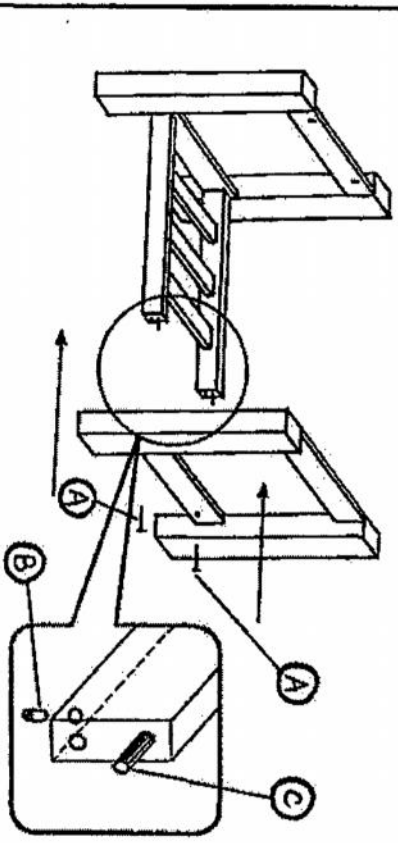

STEP 2

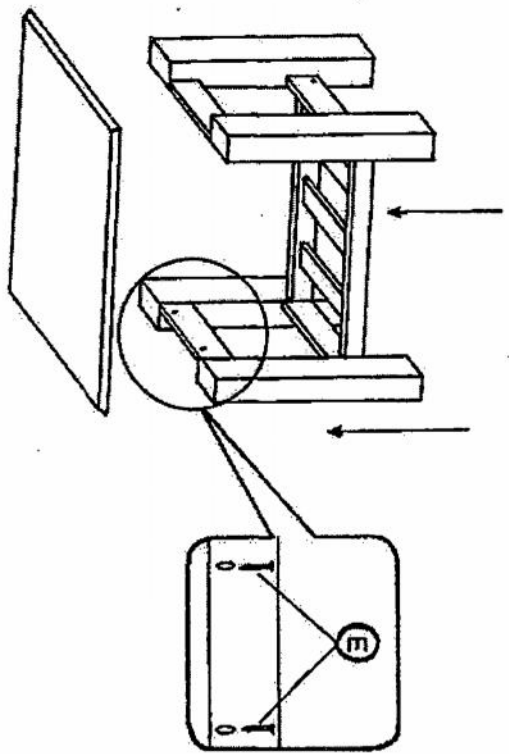

STEP 3

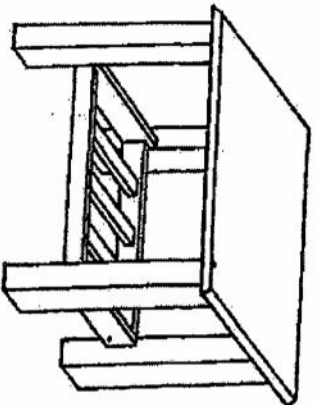

FULLY SET UP