

# SW 135 - CT

(This assembly method also apply to side table)

1.

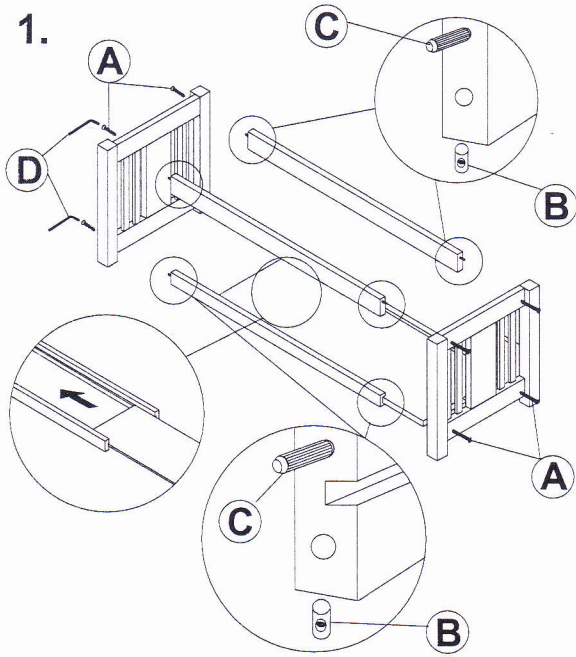

Attach the rail (upper) (P4) and the rail (lower) (P5) to the table leg (P2). Insert MDF board (P3) to the rail (lower) (P5). Complete one side first and repeat the same for the other side of table leg (P2). You will need to use hardware:

- A = 8 pcs
- B = 8 pcs
- C = 8 pcs
- D = 1 pcs

## WARNING!!

- Remove hardware from box and sort by size.
- Please check to see that hardware and parts are present prior start of assembly.
- Please follow attached instruction in the same sequence numbered to ensure fast and easy assembly.
- Do not use this table if any part is broken, torn or missing.
- The assembly of this product requires two people.
- Do not use any power tools as this may damage the frame and will invalidate any claim.

## PART LIST

P1		Table Top	=	1pcs
P2		Table Leg	=	2pcs
P3		MDF Board	=	1pcs
P4		Rail (Upper)	=	2pcs
P5		Rail (Lower)	=	2pcs

2.

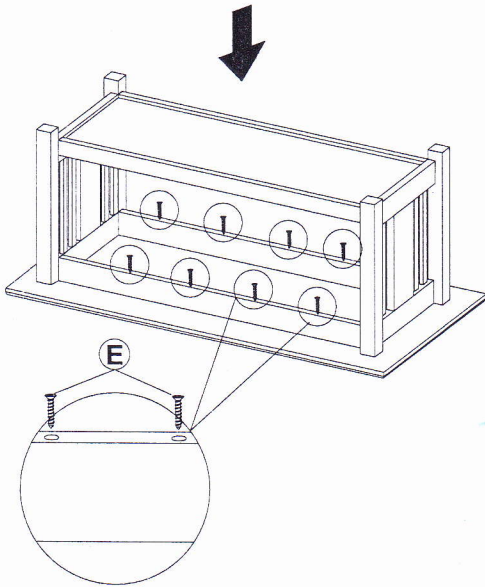

Place the table top (P1) upside down on a non-abrasive surface. Attach the table top (P1) to the rail (upper) (P4). You will need to use hardware :

- E = 8pcs (CT)
- E = 6pcs (ST)

**\*For side table only 3pcs screw each side apply only\***

## HARDWARE LIST

A		M6 X 50MM JCBC	=	8pcs
B		BARREL NUT	=	8pcs
C		O8 X 35MM WOOD DOWEL	=	8pcs
D		ALLEN KEY M4	=	1pcs
E		M4 X 25MM SCREW (CT)= (ST)=	=	8pcs 6pcs

## 3. FULLY SET UP

