

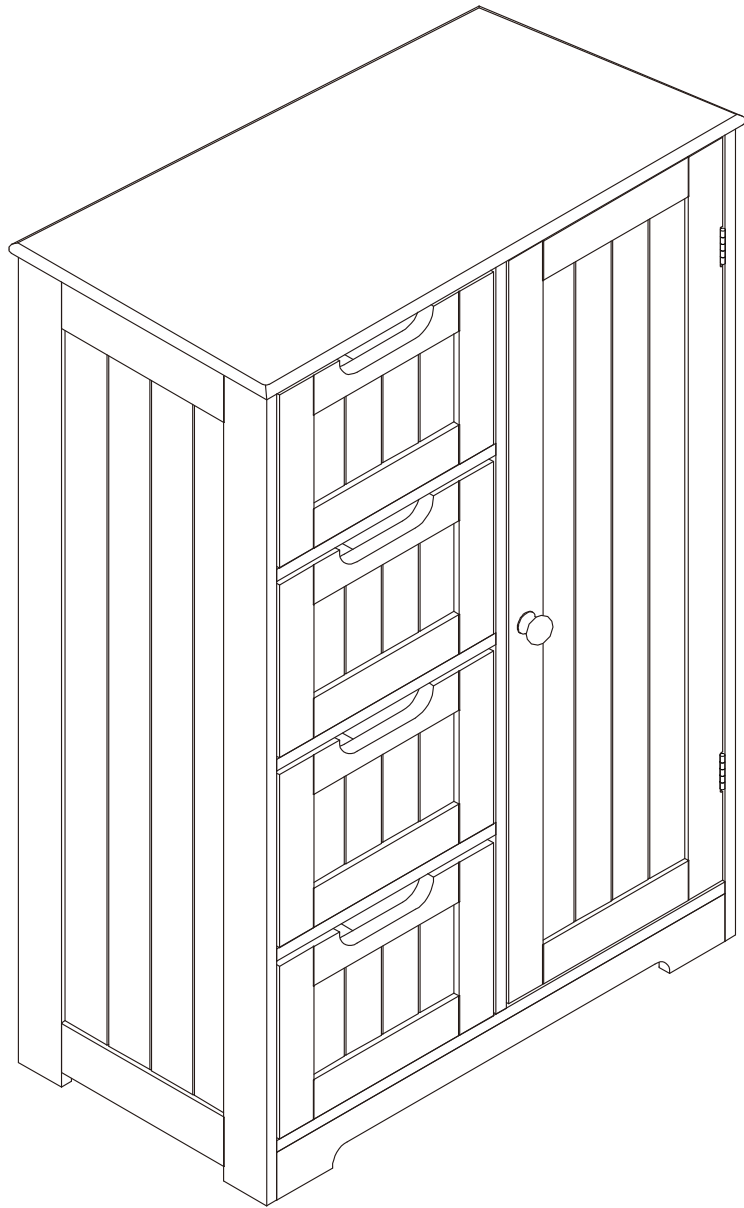

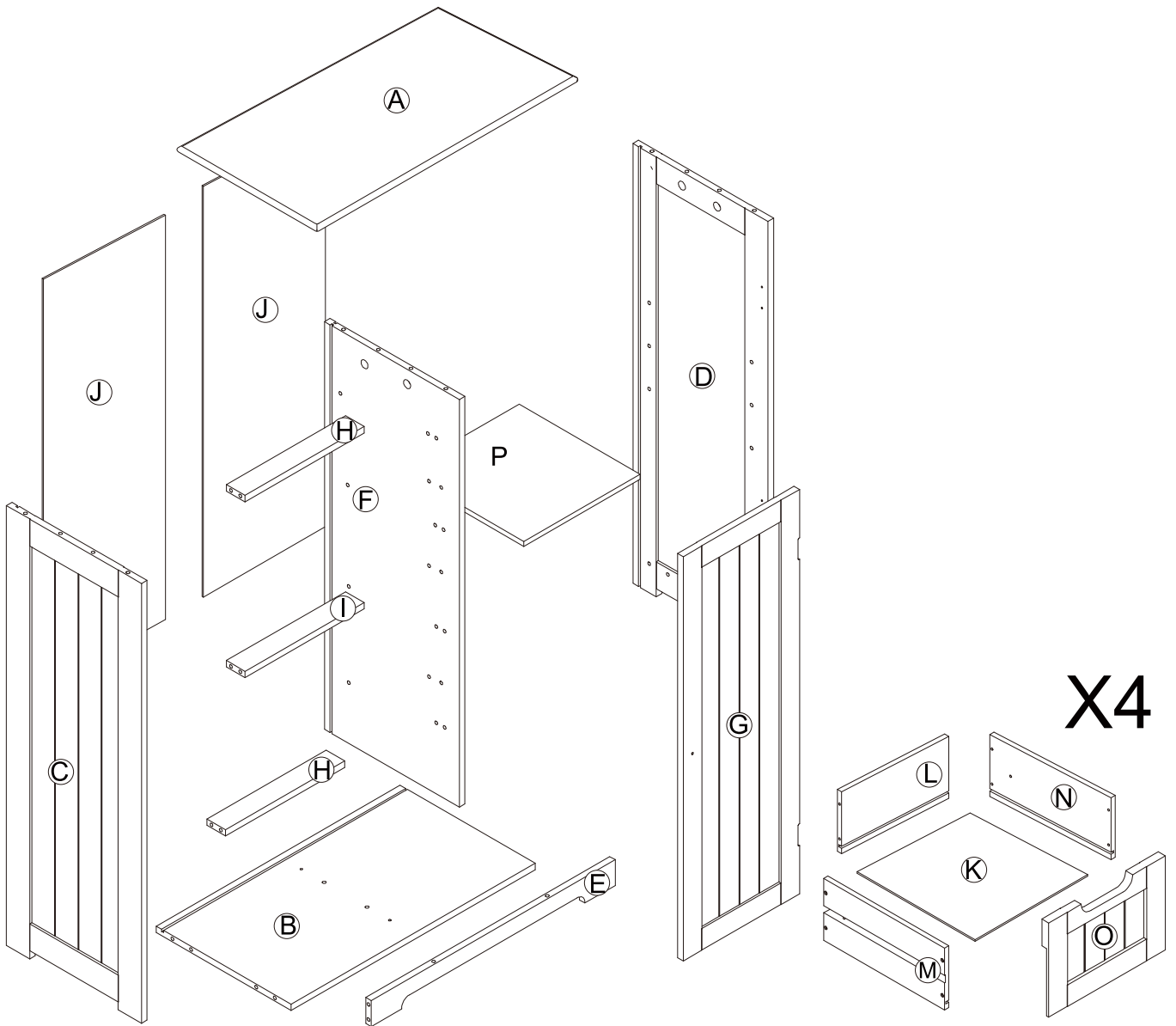







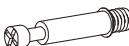



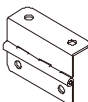

WI 11334

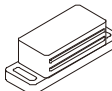

Parts List



1  6x30mm 28PCS	2  6x35mm 12PCS	3  15x9.5mm 12PCS	4  4x30mm 2PCS
5  3x10mm 25PCS	6  2.5x14mm 2PCS	7  2PCS	8  3x25mm 32PCS
9  4x25mm 1PC	10  1PC	11  1PC	12  1PC
13  4PCS	14  8PCS	15  8PCS	16  6 PCS

Assembly Steps

STEP 1

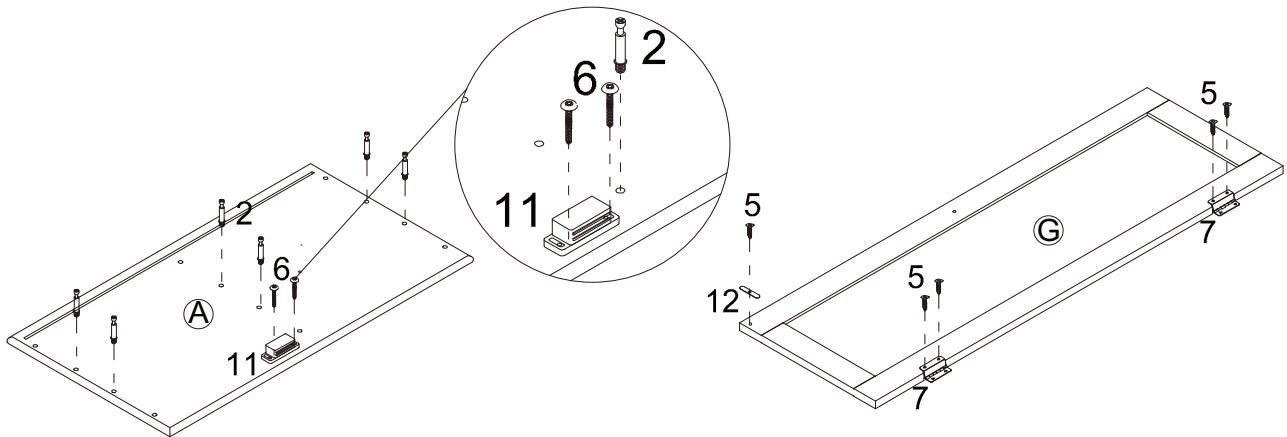

	(2)x 6 pcs
	(5)x 5 pcs
	(6)x 2 pcs
	(7)x 2 pcs
	(11)x 1 pc
	(12)x 1 pc

Fix hardware 2 to Part A, and then fix hardware 11 to Part A with screw 6.

Fix hardware 12 and 7 to Part G with screw 5.

STEP 2

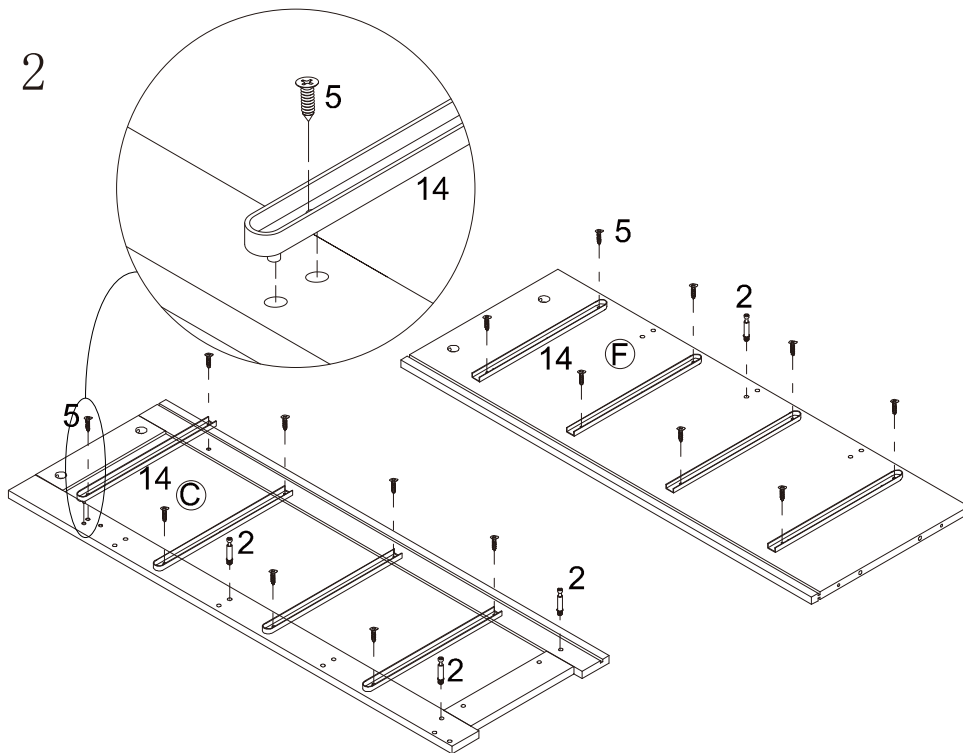





	(2)x 4 pcs
	(5)x 16 pcs
	(14)x 8 pcs

Fix hardware 2 to Part C and F, and then fix hardware 14 to Part C and F with screw 5.

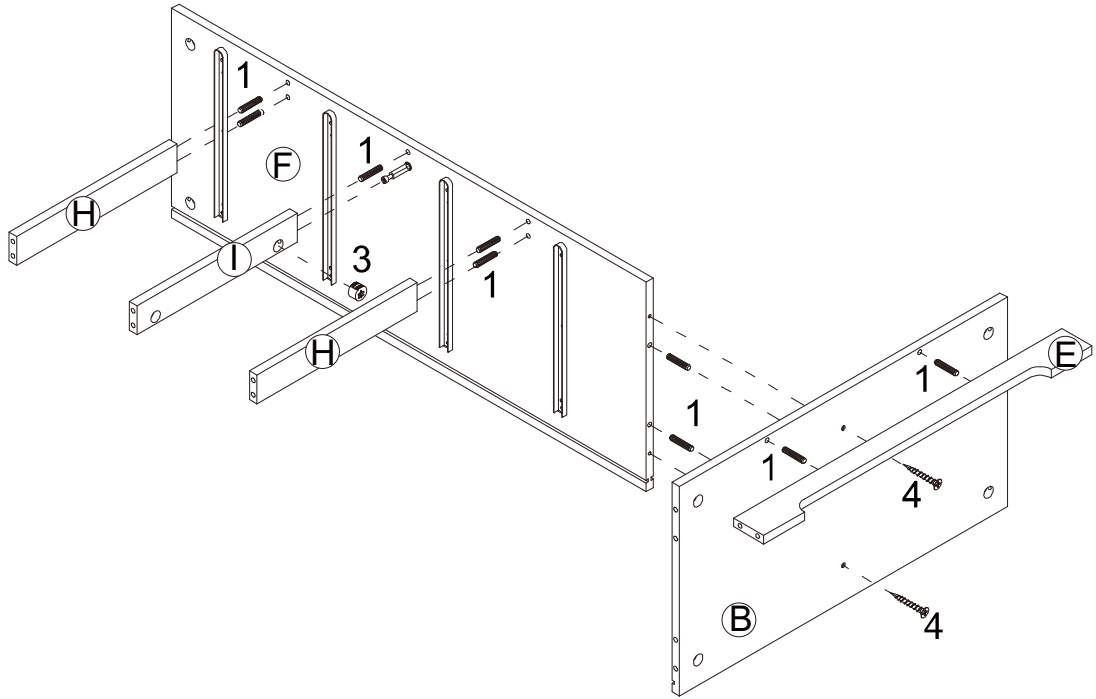
Assembly Steps

STEP 3





	(1)x9pcs
	(3)x1pc
	(4)x2pcs

Connect Part I to Part F with hardware 1,
and then screw Part I to Part F with hardware 3.
Fix Part E to Part B with hardware 1 and 4.
Then fix Part B to Part F with hardware 1 and 4.

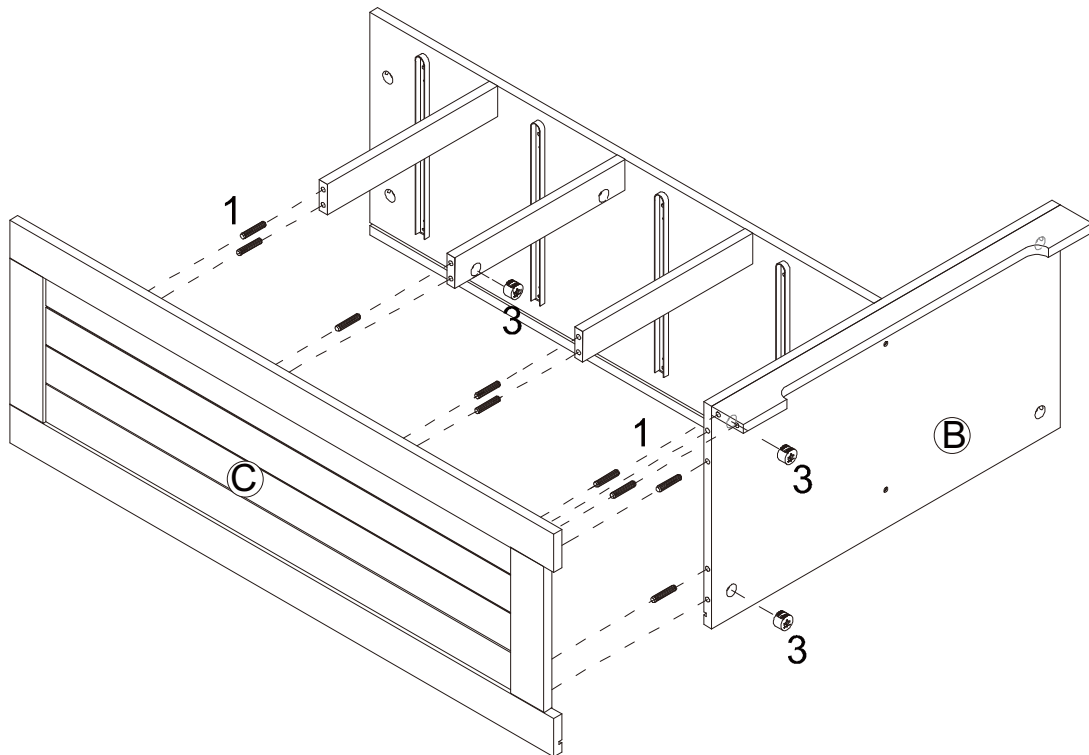
STEP 4







	(1)x9pcs
	(3)x3pcs

Connect Part C to B with hardware 1 and 3.

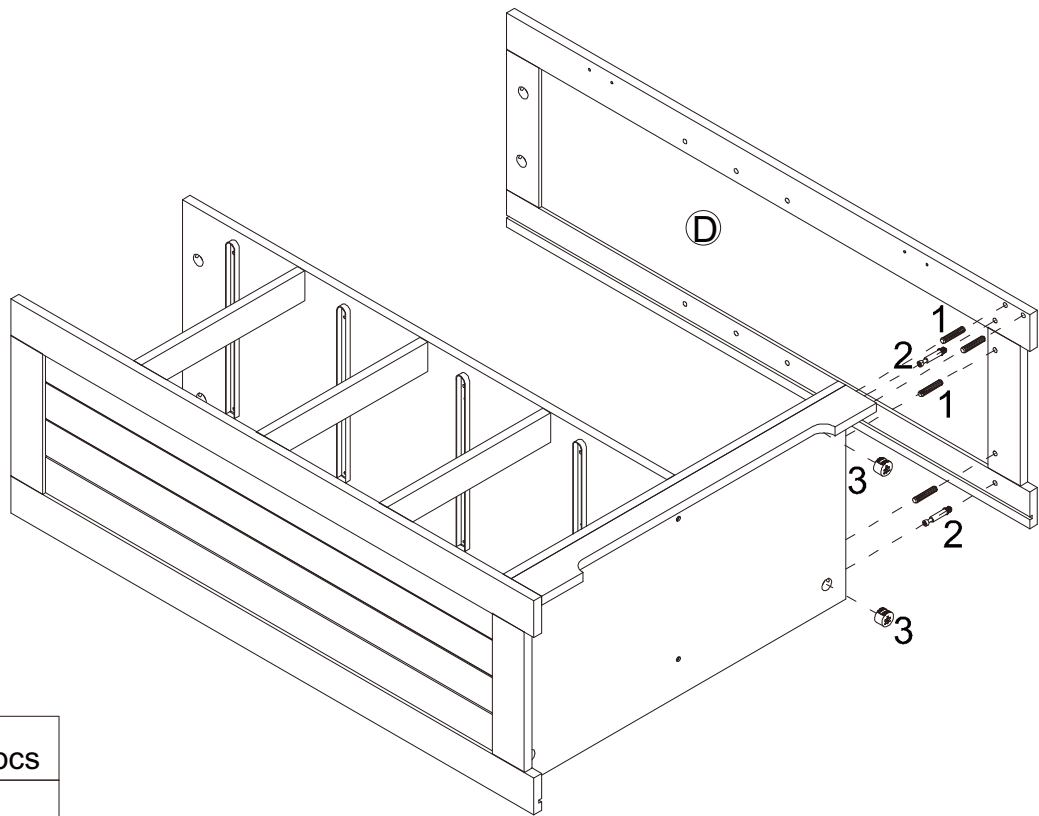
Assembly Steps

STEP 5



	(1)x4pcs
	(2)x2pcs
	(3)x2pcs

Fix hardware 2 to Part D,
and then connect Part D to Part B with hardware 1 and 3.

STEP 6

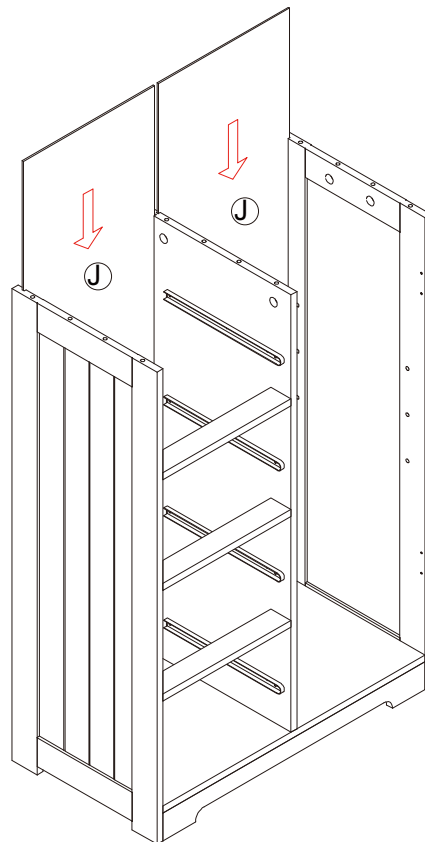

Put Part J to the groove.

Assembly Steps

STEP 7

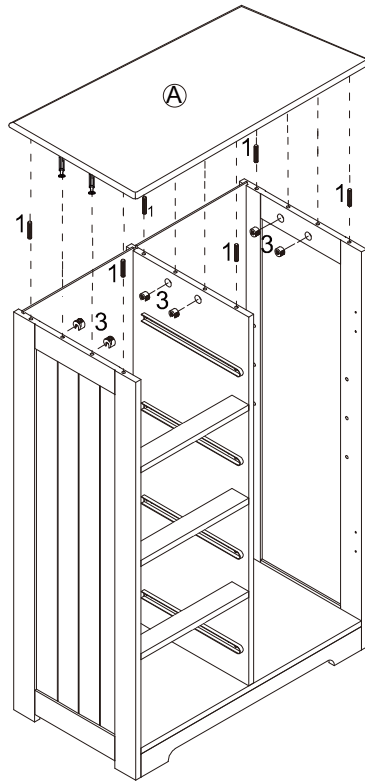

(1)x6pcs



(3)x6pcs

Fix Part A to the top with hardware 1 and 3.

STEP 8

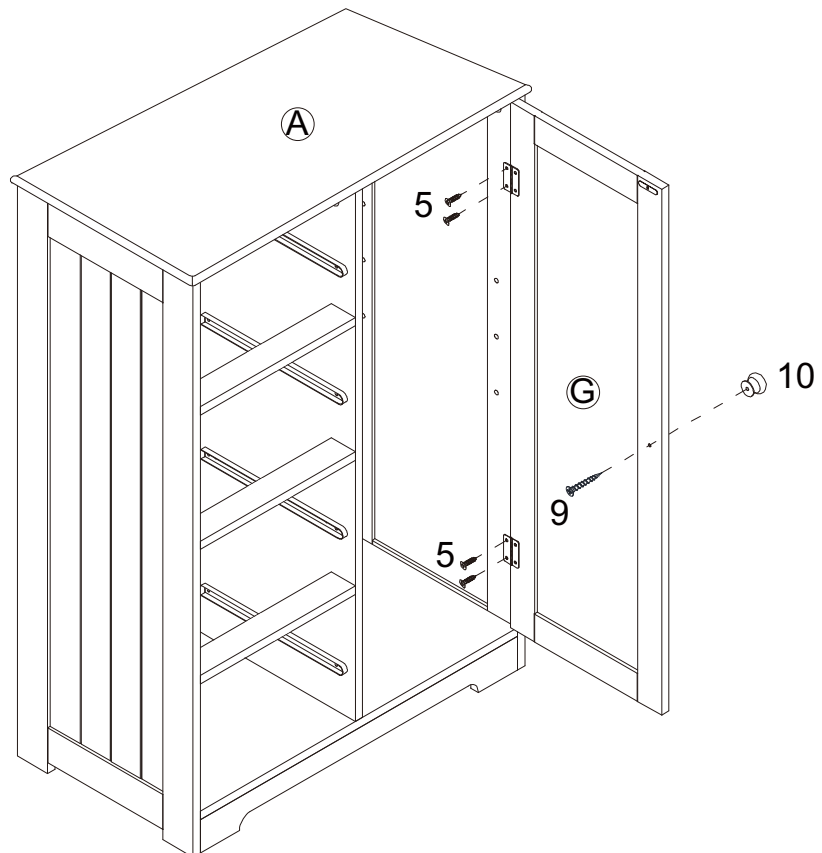

(5)x4pcs



(9)x1pc



(10)x1pc

Fix Part G to Part D with hardware 5,
and then fix handle 10 to Part G with screw 9.

Assembly Steps

STEP 9

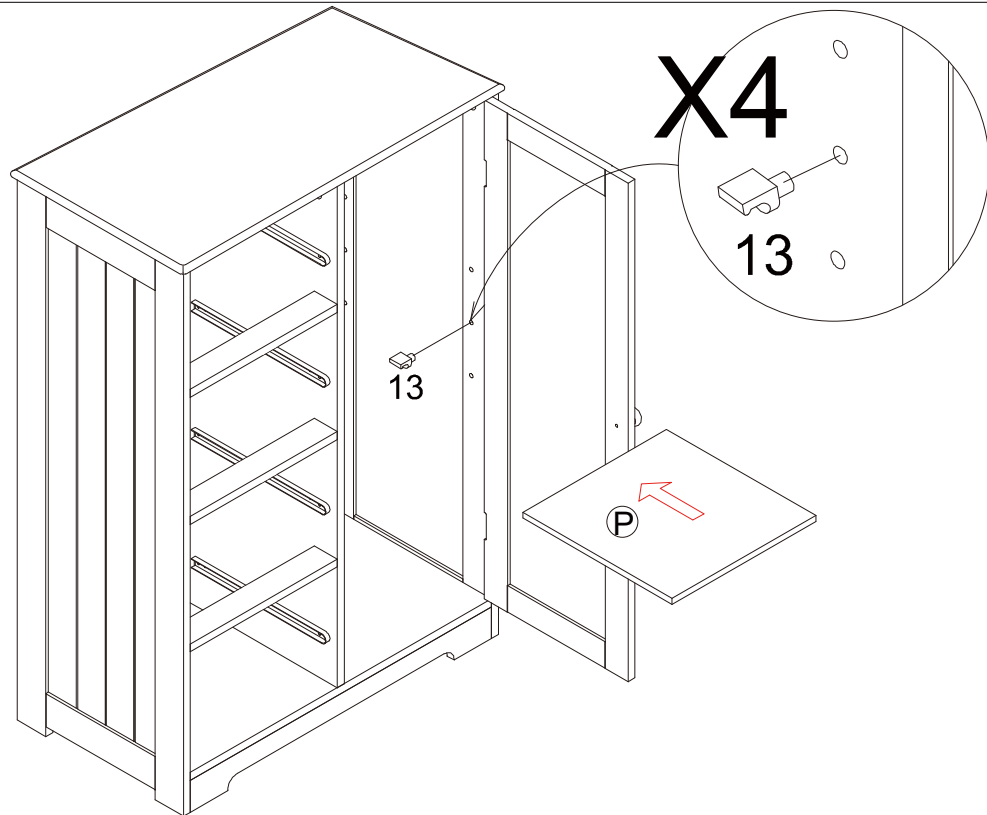

Put hardware 13 to the screw hole and then put Part P into the frame.

 (13)x4pcs

STEP 10

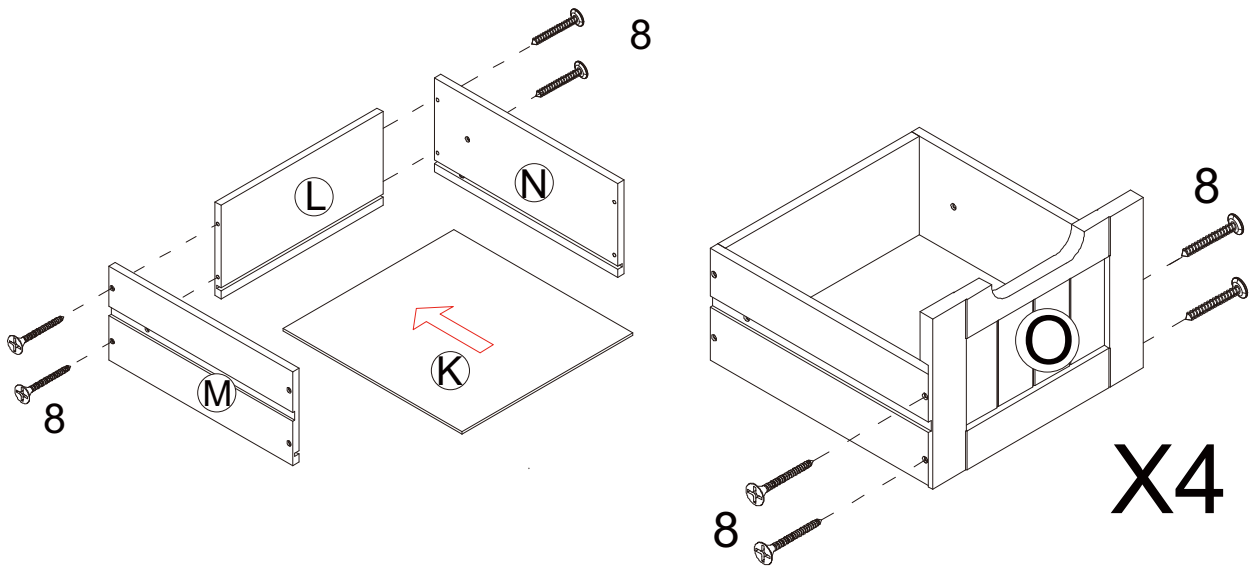



Fix Part N and M to Part L with screw 8, and then put Part K to the groove of Part N and M.

 (8)x32pcs

Fix Part O to Part N and M with screw 8.

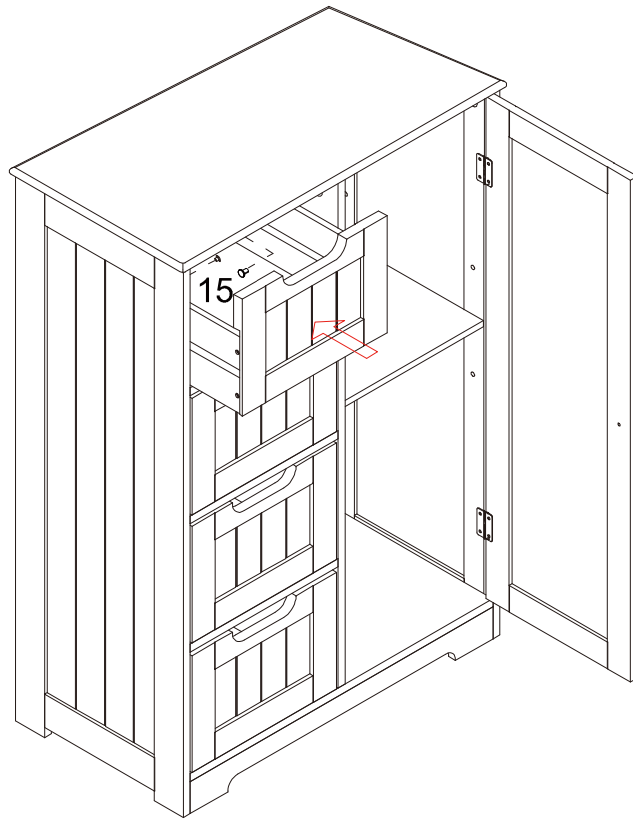
Assembly Steps





 (15)x8pcs

Fix hardware 15 to drawer side panel.

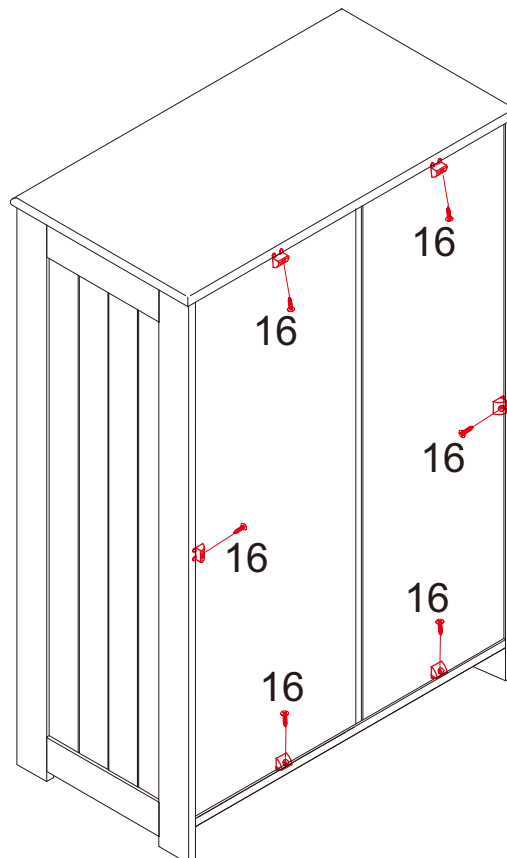
STEP 11



  (16)x6pcs

Fix hardware 16 to back panel to stabilize whole cabinet.