

ASSEMBLY INSTRUCTION

MODEL : 318P

Read this instruction carefully. Remove all wrapping material, staples and straps from the carton.







See hardware and furniture part list

For guidance. Be sure you have all wooden furniture parts on a clean and flat soft surface, such as a carpet or rug, to prevent from being scratched. Follow the figure to start assembling.

CAUTION :

1. Do not FULLY - TIGHTEN the nut or screw until all is ready to assemble.
2. Do not OVER - TIGHTEN the nut or screw to avoid causing damages to the thread.
3. Keep all hardware part out reach of children.

NO	PART LIST	QTY
A	BACK REST	1 PC
B	FRONT LEG	1 PC
C	SIDE RAIL	2 PCS
D	CUSHION SEAT	1 PC
E	SRETCHER	2 PCS

NO	DESRPTION	QTY
1	JCBC SCREW M6 X 50MM 	6 PCS
2	CSK SCREW M4 x 38MM 	4 PCS
3	CSK SCREW M4 x 30MM 	3 PCS
4	WOOD DOWEL Ø8 x 30MM 	4 PCS
5	SPRNG WASHER M6 	6 PCS
6	M4 ALLEN KEY 	1 PC

STEP 1

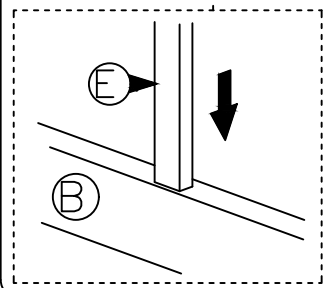
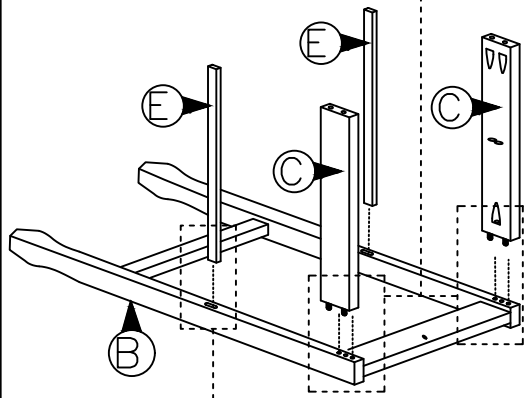
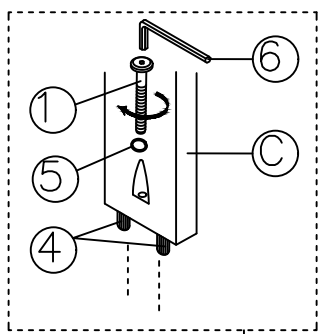

STEP 2

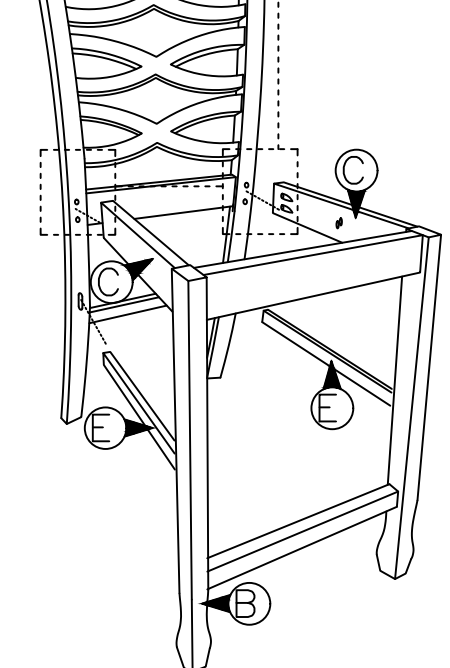
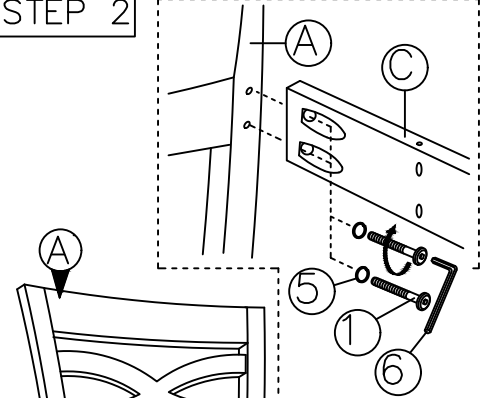

STEP 3

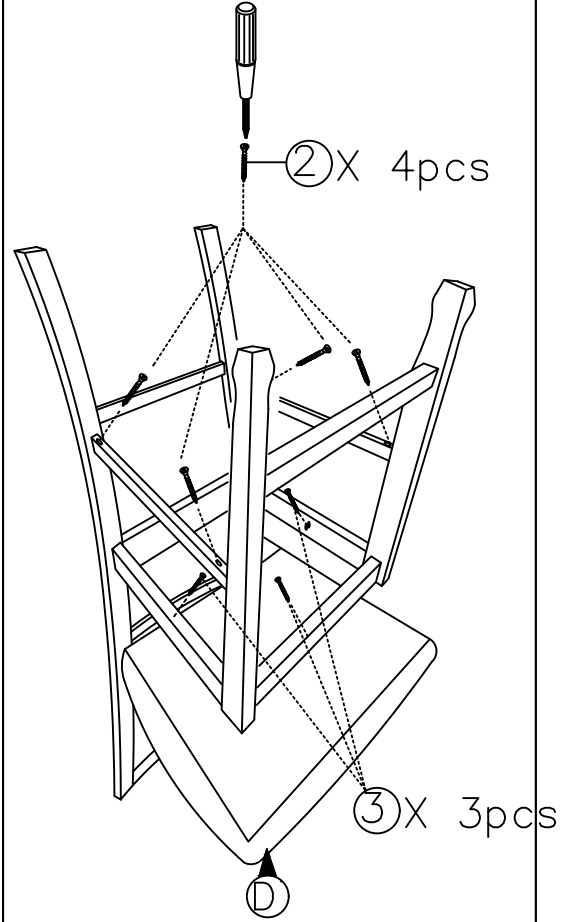

STEP 4

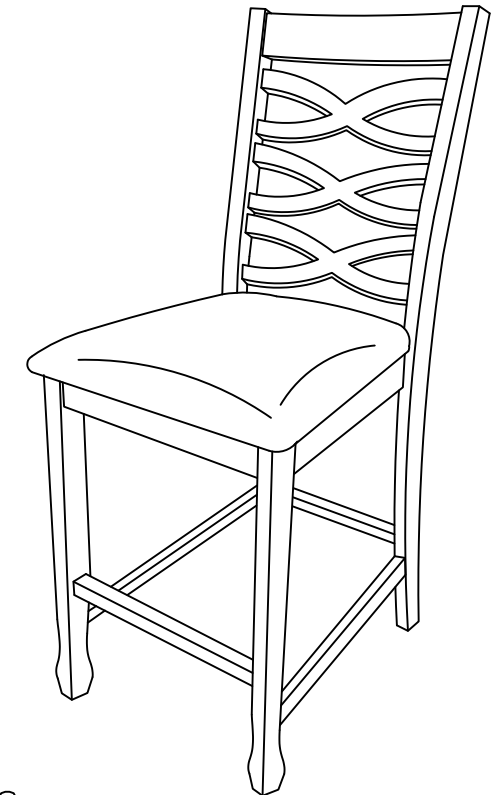

COMPELETE ASSEMBLE