

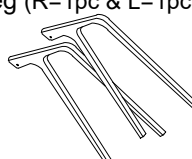









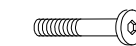

# ASSEMBLY INSTRUCTIONS

MODEL : RDC 809

ITEM	HARDWARE NAME	QTY	ITEM	HARDWARE NAME	QTY
1	Leg (R=1pc & L=1pc) 	2 PCS	A	JCBC BOLT M6 X 50 mm 	8 PCS
			B	JCBC BOLT M6 X 35 mm 	2 PCS
			C	SPRING WASHER M6 	8 PCS
2	Back Rest 	1 PC	D	WOOD DOWEL M8x30mm 	2 PCS
			E	CSK SCREW M4 x 12 mm 	8 PCS
3	Cushion Seat 	1 PC	F	Wood Button 	2 PCS
			G	ALLEN KEY M4 	1 PC
4	Apron 	2 PCS	H	BRACKET 	4 PCS

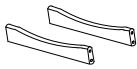

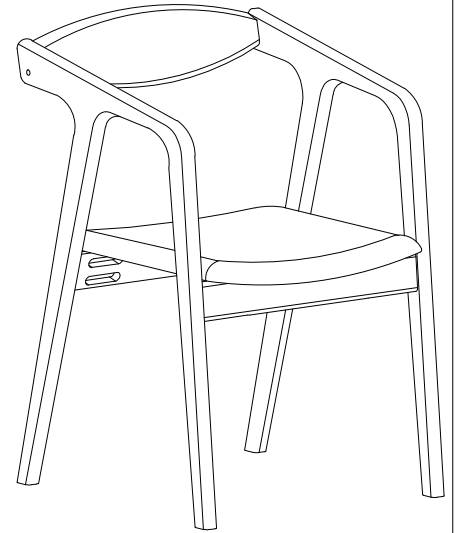
FULLY SET-UP

## Step 1

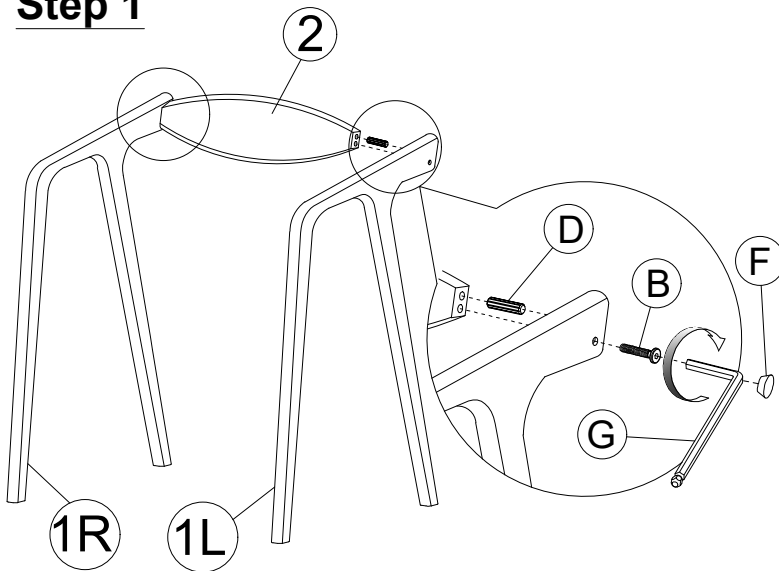

## Step 2

### MARKING

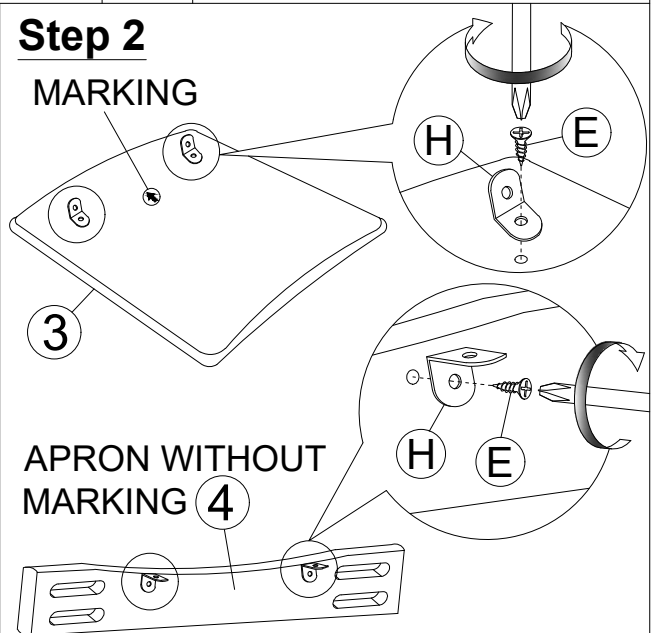

### APRON WITHOUT MARKING 4

## Step 3

### APRON WITHOUT BRACKET 4

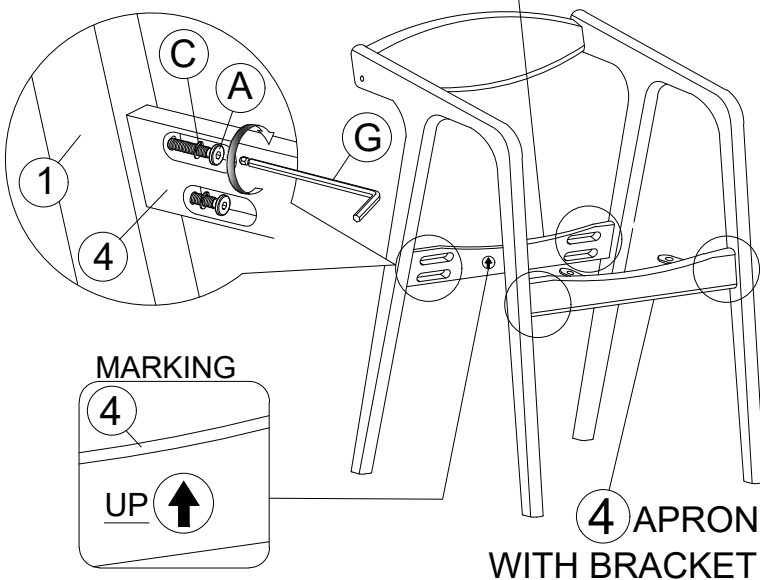



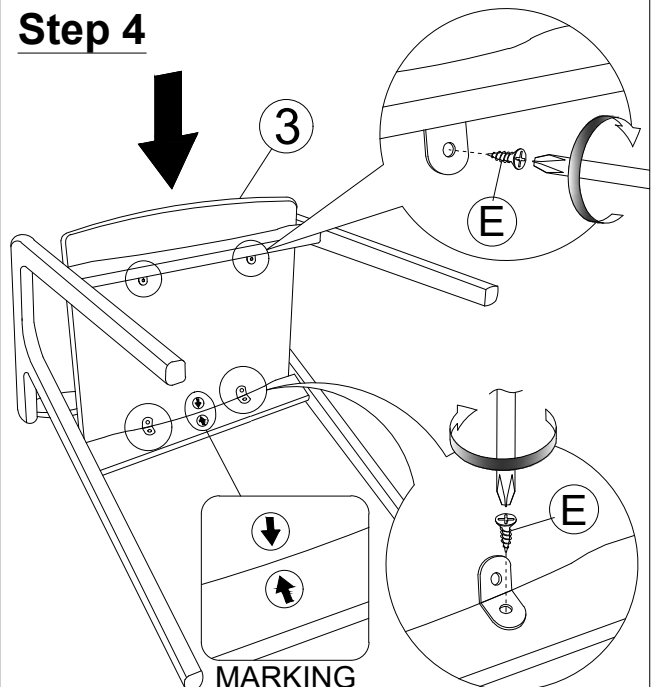





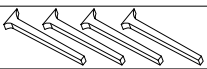
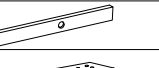

## Step 4

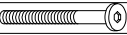

# ASSEMBLY INSTRUCTIONS

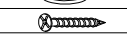
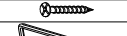
## MODEL : RDT 347 (1500)

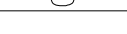
ITEM	PART LIST	QTY
1	Table Top 	1 PC
2	Table Leg 	4 PCS
3	Leg Support 	2 PC
4	Table Base 	2 PCS
5	Table Support 	2 PCS

ITEM	HARDWARE LIST	DESCRIPTION	QTY
A	JCBC Bolt M6 x 50 mm		4 PCS
B	JCBC Bolt M6 x 40 mm		8 PCS
C	WOOD DOWEL M8 x 30 mm		8 PCS
D	Spring Washer		12 PCS
E	Flat Washer M6 x 13mm		12 PCS
F	CSK M4 x 30 mm		10 PCS
G	CSK M4 x 13 mm		6 PCS
H	Allan Key		1 PC
J	Wood Button 14.5		4 PCS



### STEP 1

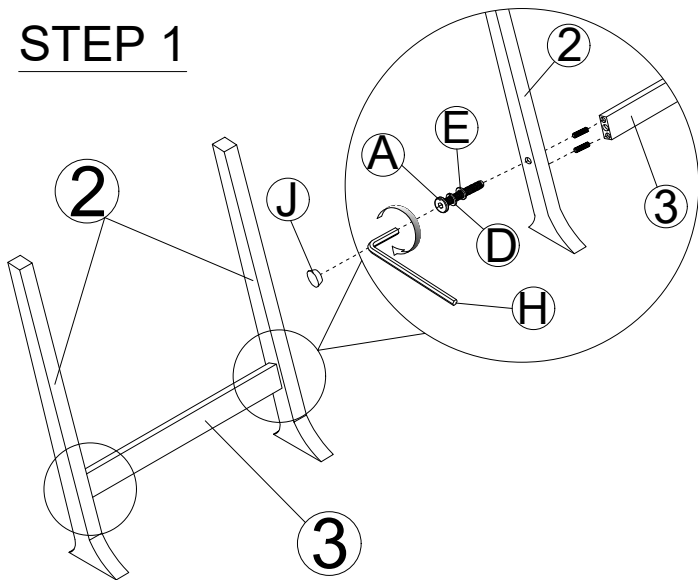

### STEP 2

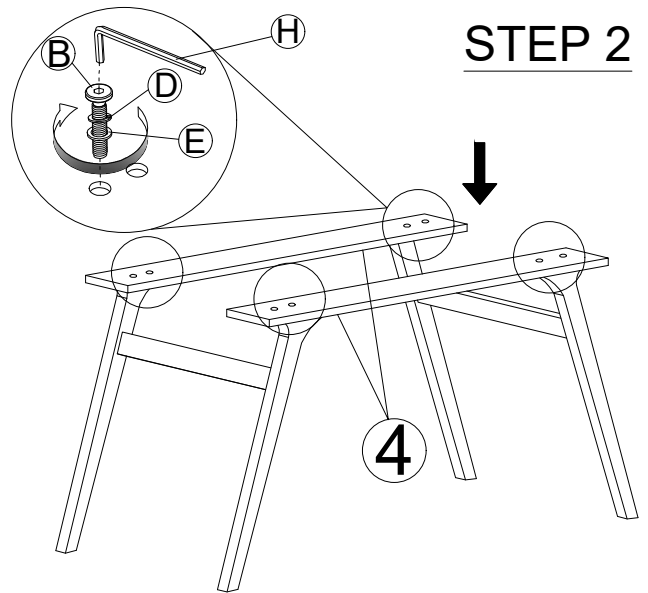

### STEP 3

