











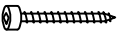

Assembly Instructions

NS 8016

Part List		QTY
1	Top Panel	1
2	Left Side Panel	1
3	Right Side Panel	1
4	Middle Panel	1
5	Bottom Panel	1
6	Back Panel	1
7	Drawer Front Panel	2
8	Drawer Side Panel	4
9	Drawer Back Panel	2
10	Drawer Bottom Panel	2
11	Legs	4

Hardware		QTY
A	Allen Key M4 	1
B	Wood Dowel 	12
C	JCBC W Screw M6x40 	4
D	Mini Fix Bolt 	8
E	Mini Fix Housing 	8
F	Mini Fix Cap 	8
G	CSK Screw M3.5x16mm 	40
H	CSK Screw M4x50mm 	16
I	Handle 	4
J	Handle screw 	8
K	Drawer Slider 	2
L	Nail 	18

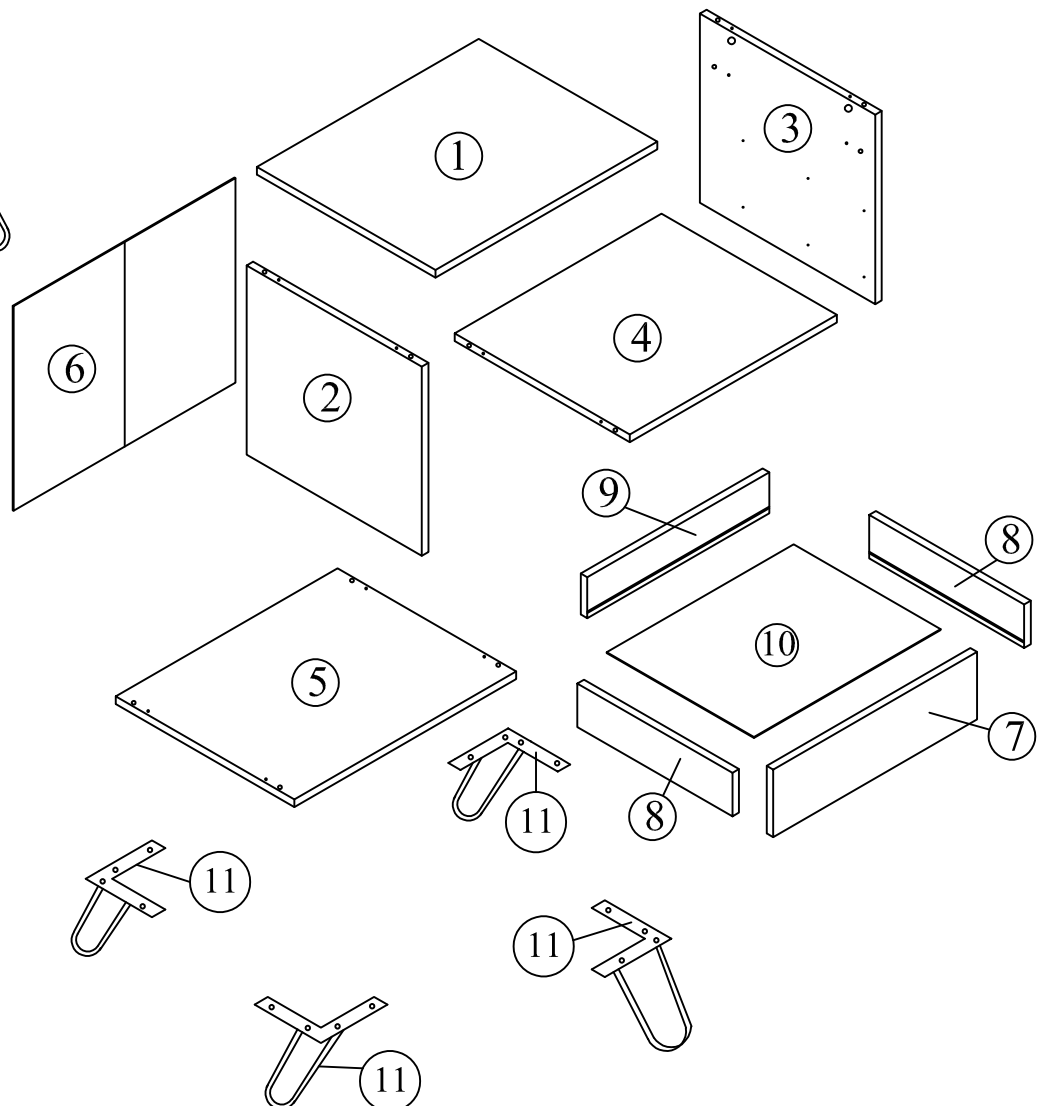
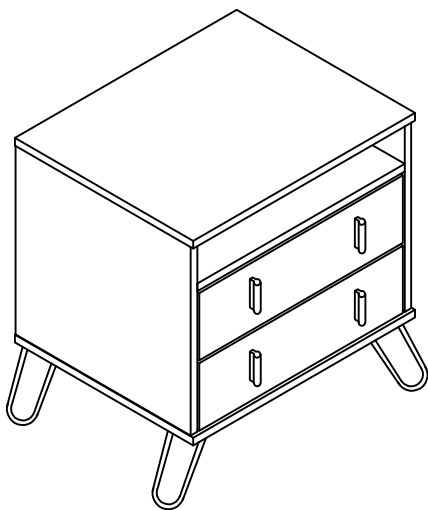

Step 1

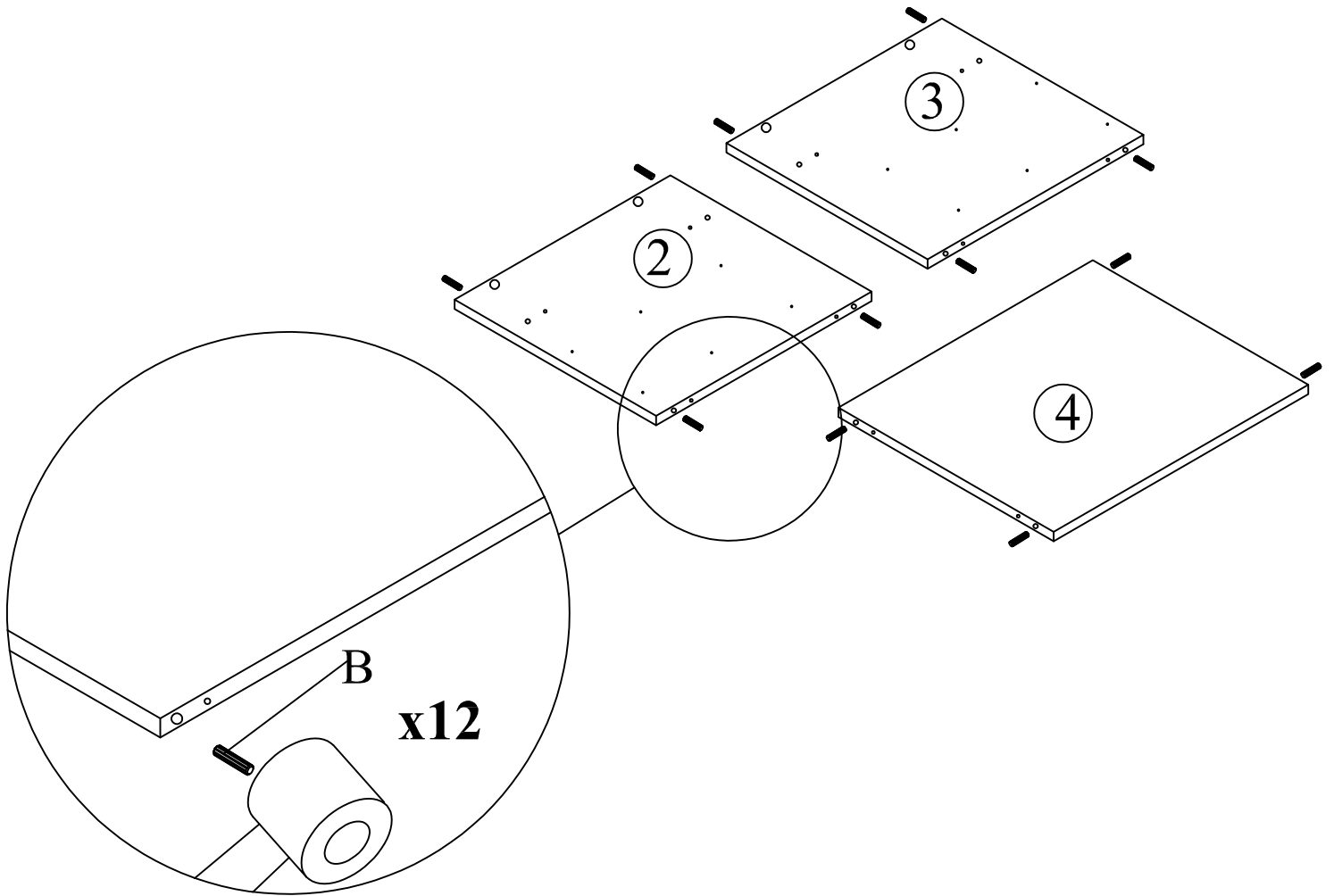

Step 2

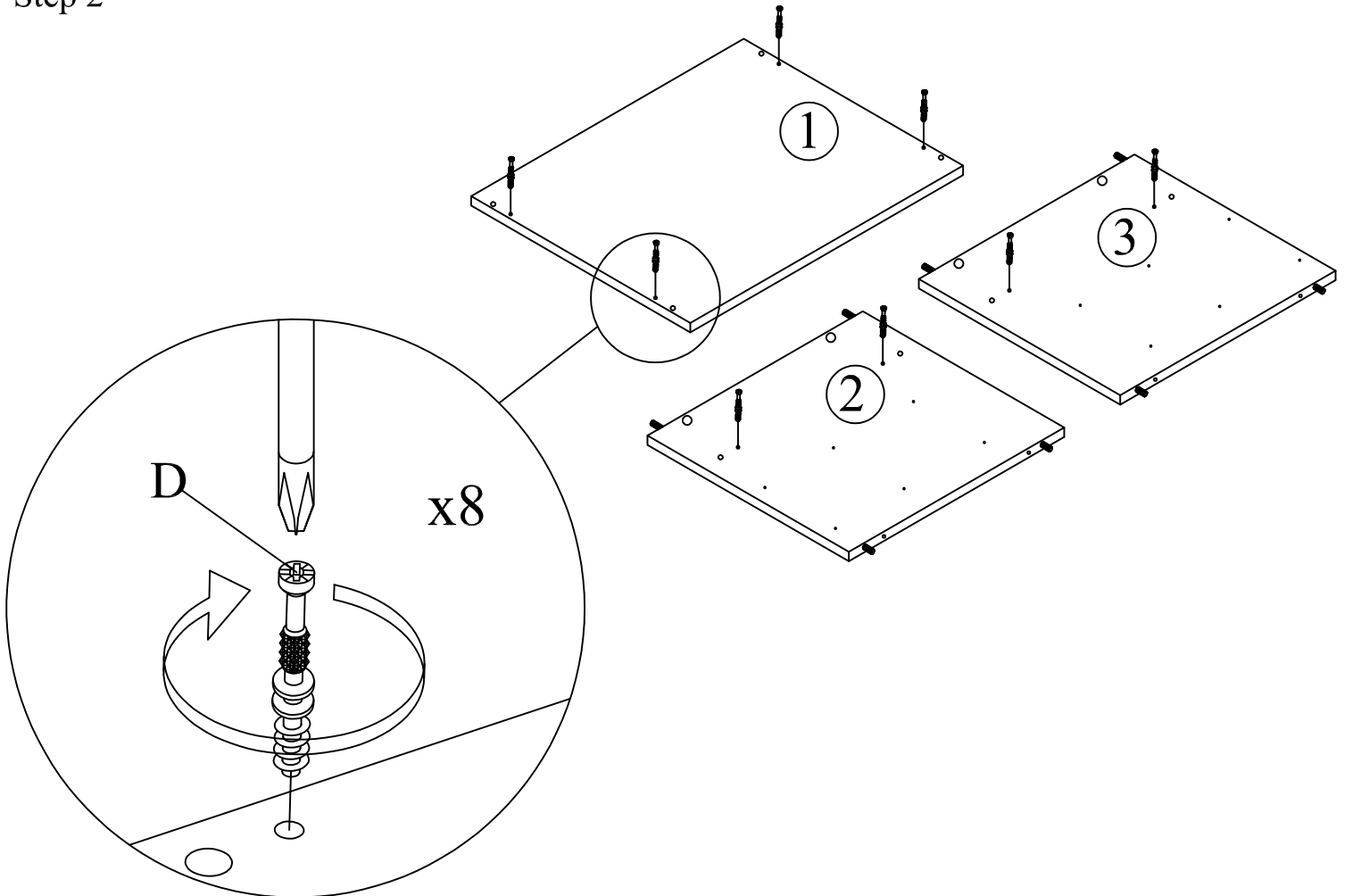

Step 3

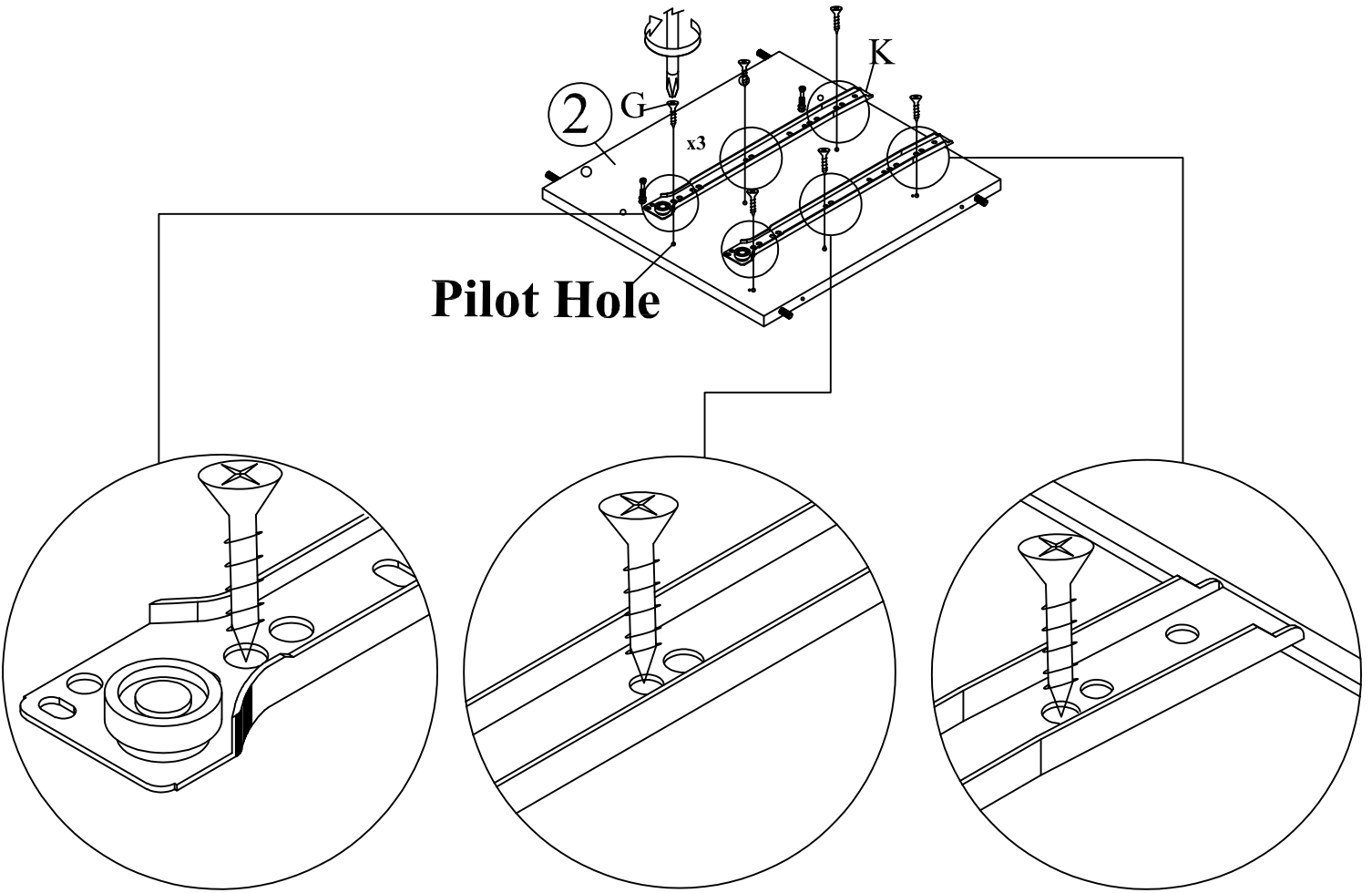

Step 4

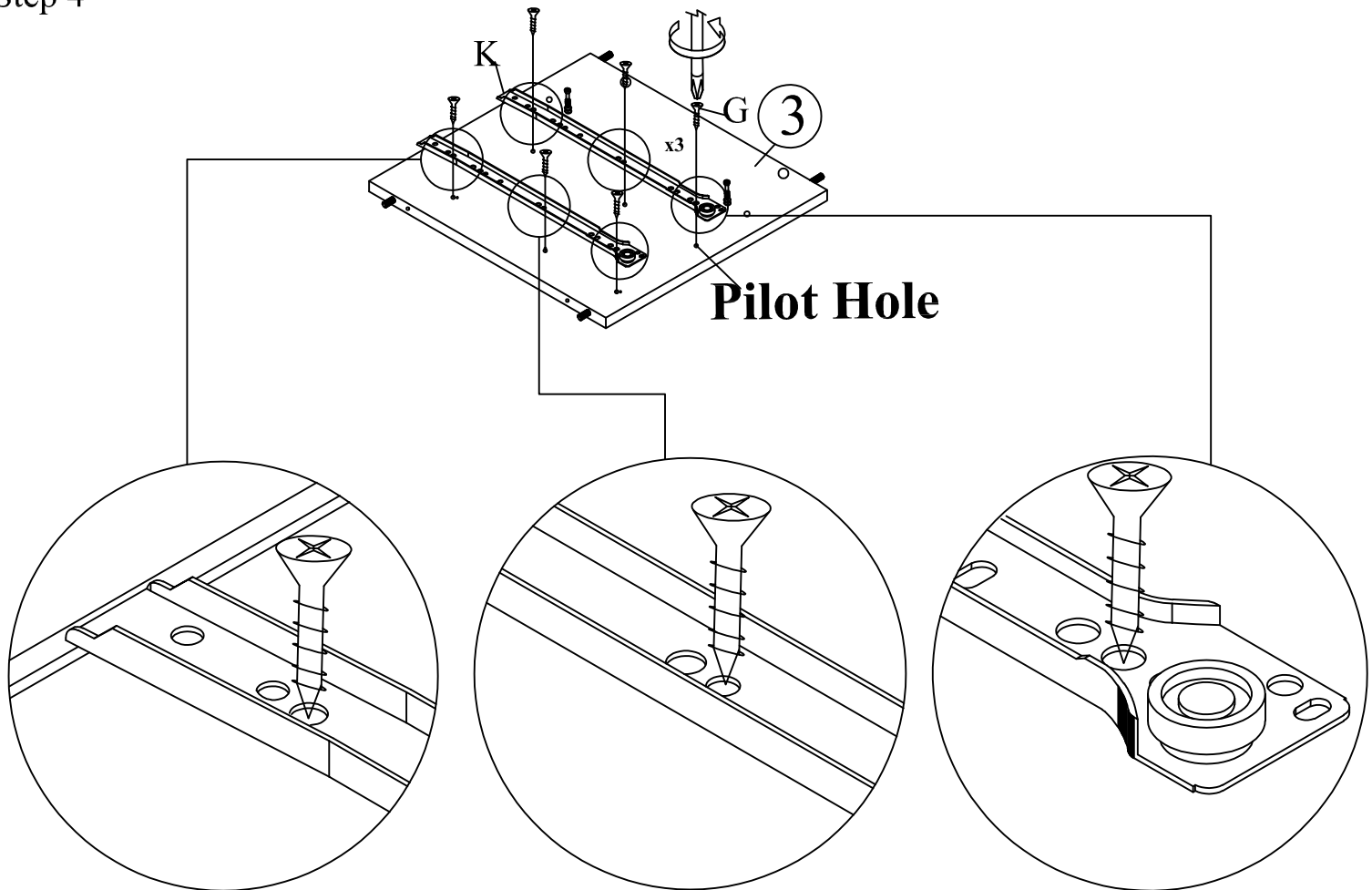

Step 5

This is how a mini fix works...

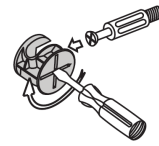

The head of the mini fix housing goes into the open mouth of the mini fix bolt. You then turn the mini fix housing so it tightens over the mini fix bolt.

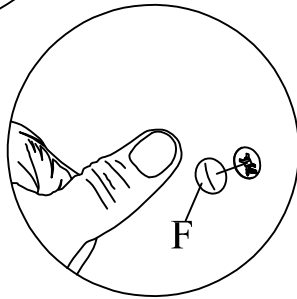
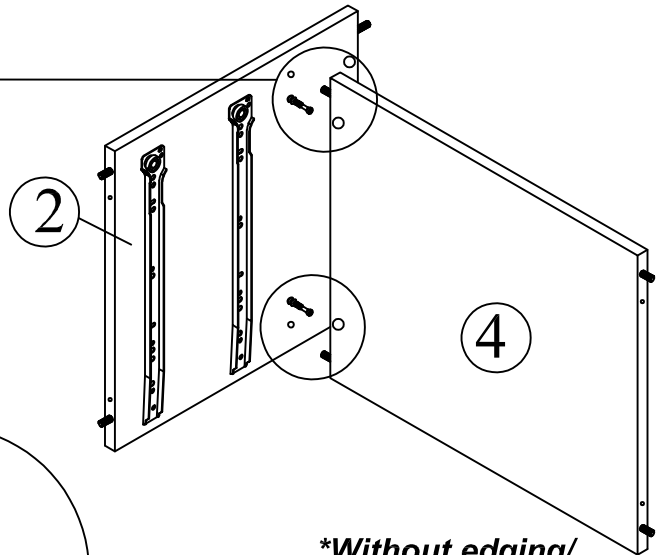
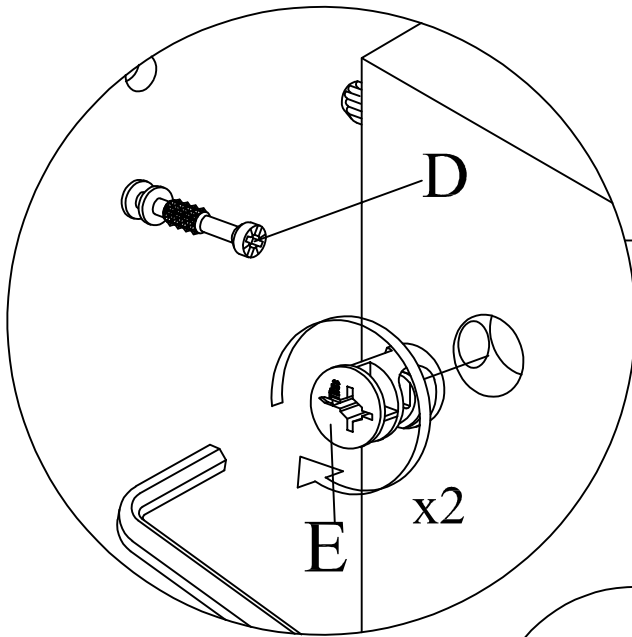

***Attach Minifix Cap as shown.**

***Without edging/
veneer facing
downward** ↓

Step 6

This is how a mini fix works...

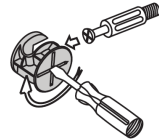

The head of the mini fix housing goes into the open mouth of the mini fix bolt. You then turn the mini fix housing so it tightens over the mini fix bolt.

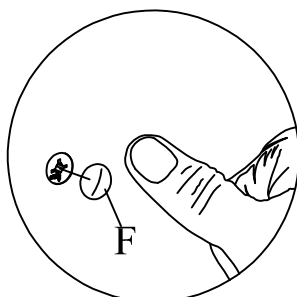
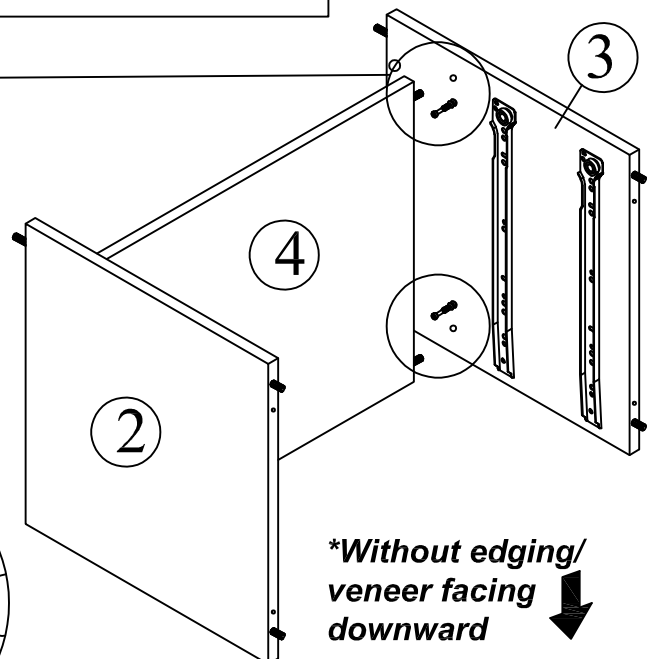
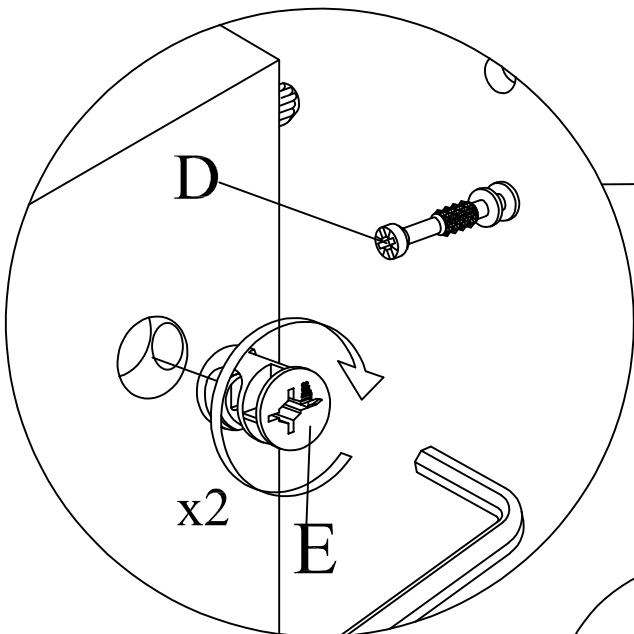

***Attach Minifix Cap as shown.**

***Without edging/
veneer facing
downward** ↓

Step 7

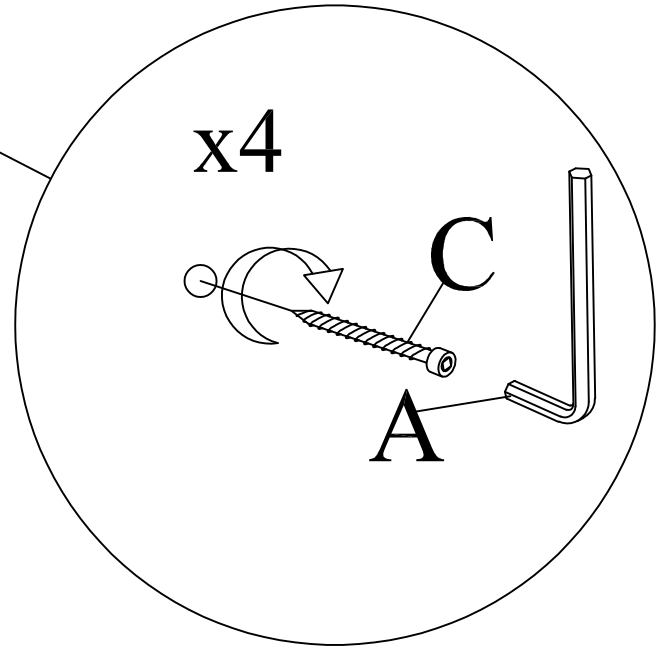
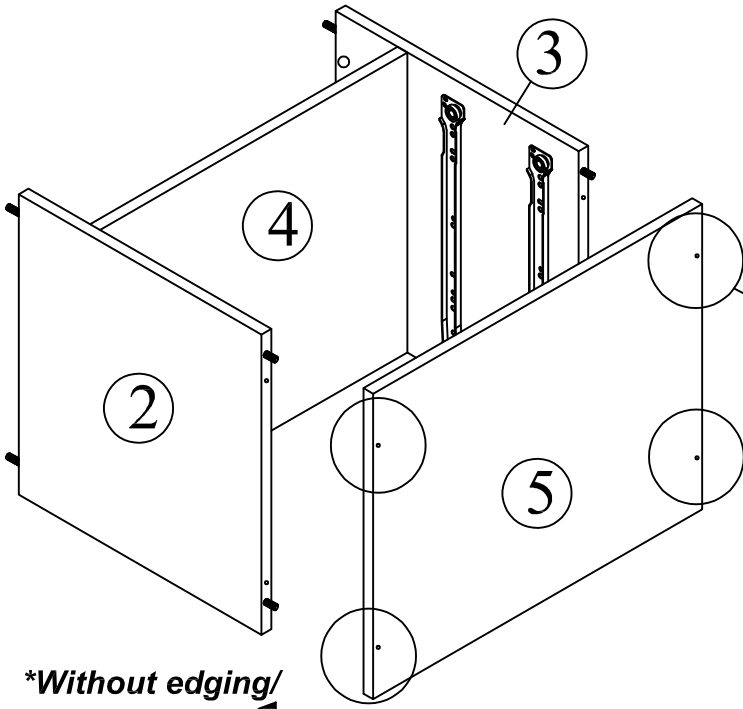

***Without edging/
veneer facing
downward** ↓

Step 8

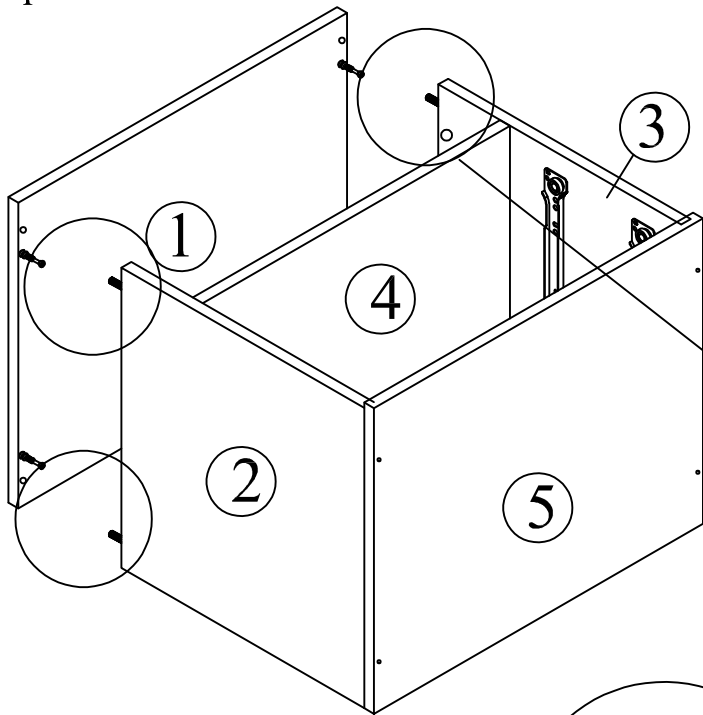

This is how a mini fix works...

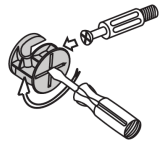

The head of the mini fix housing goes into the open mouth of the mini fix bolt. You then turn the mini fix housing so it tightens over the mini fix bolt.

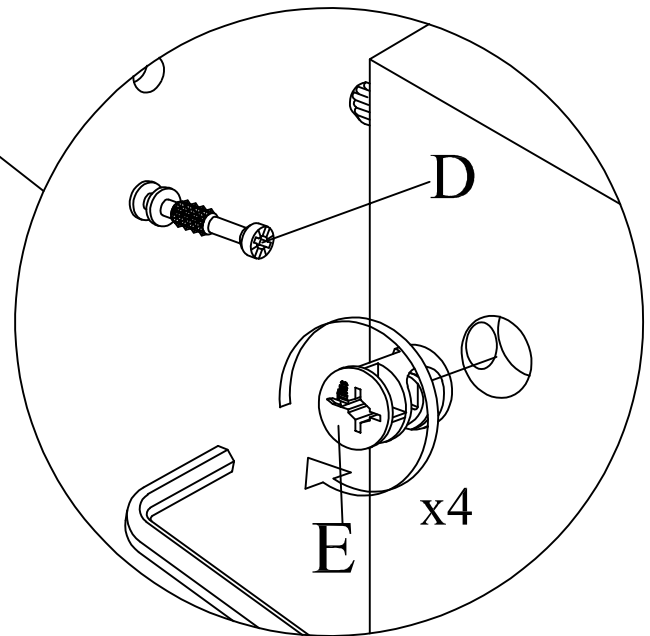

***Without edging/
veneer facing
downward** ↓

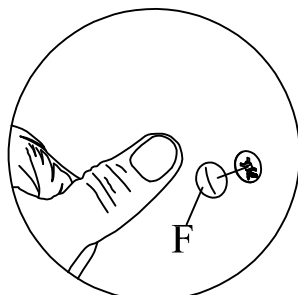

***Attach Minifix Cap as shown.**

Step 9

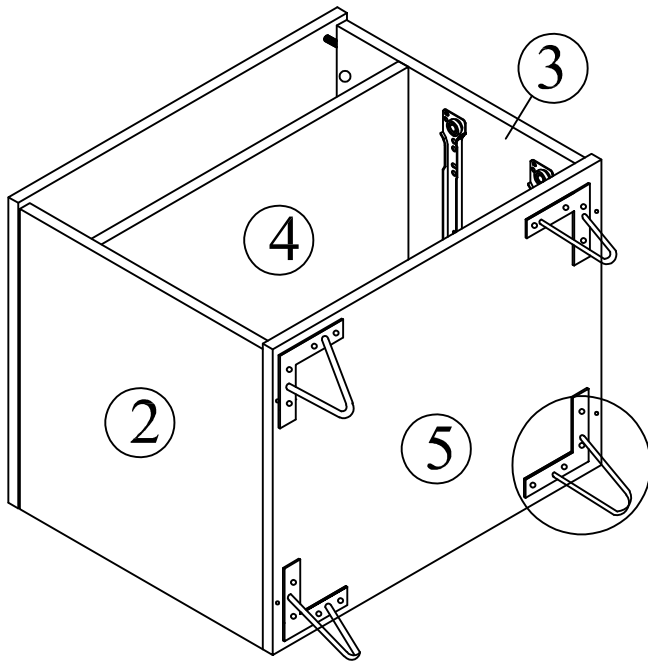

**Without edging/
veneer facing
downward* ↓

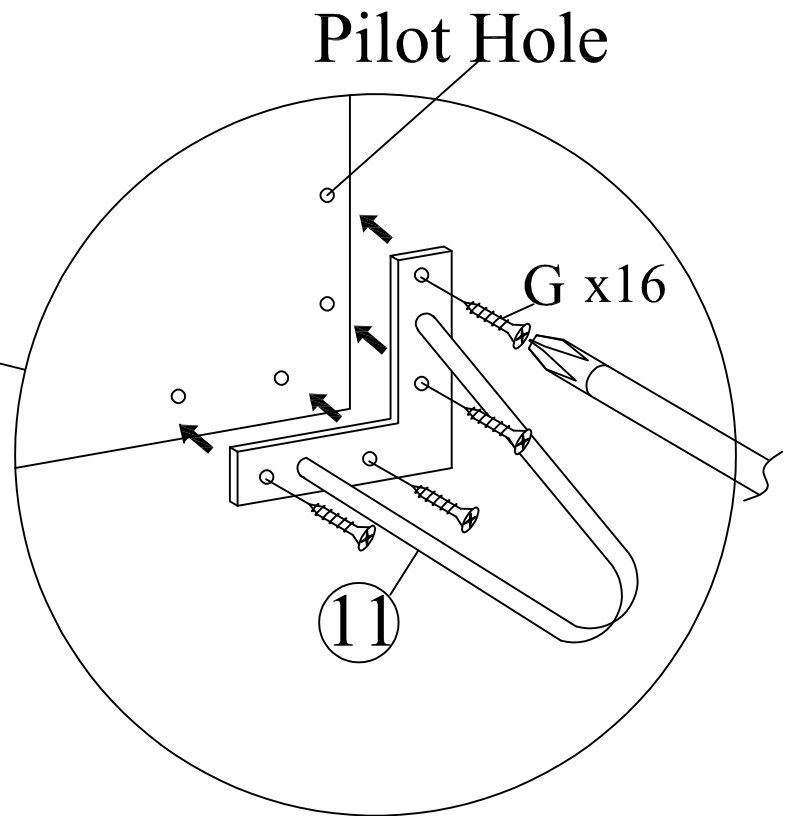

Step 10

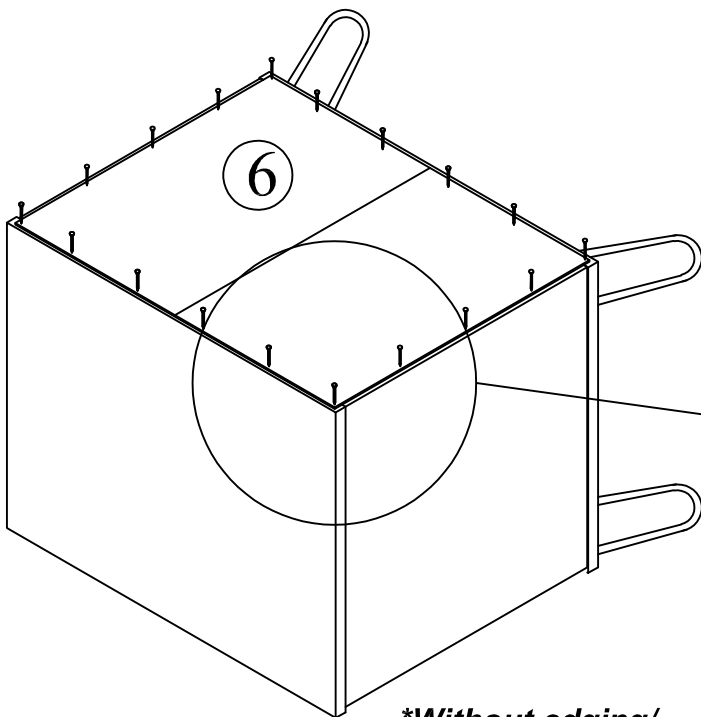

**Without edging/
veneer facing
upward* ↑

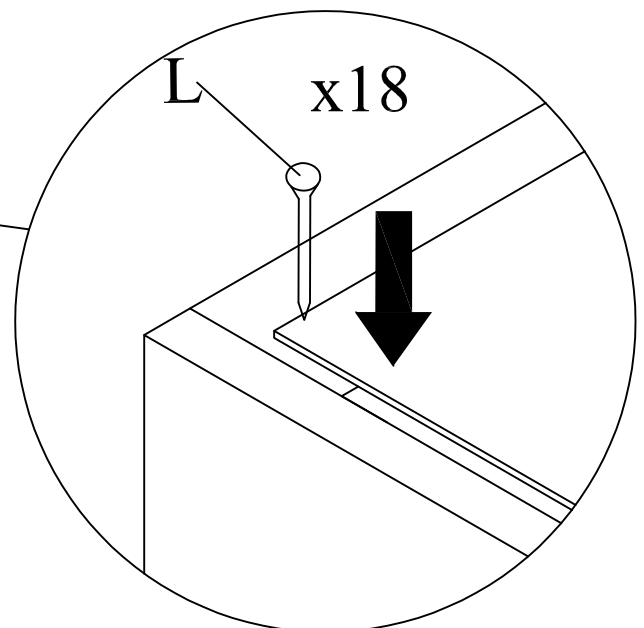
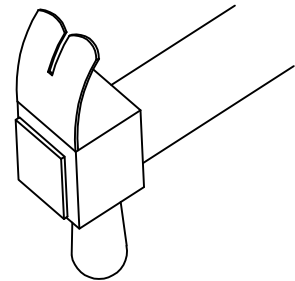

Step 11

x2

Step 11.1

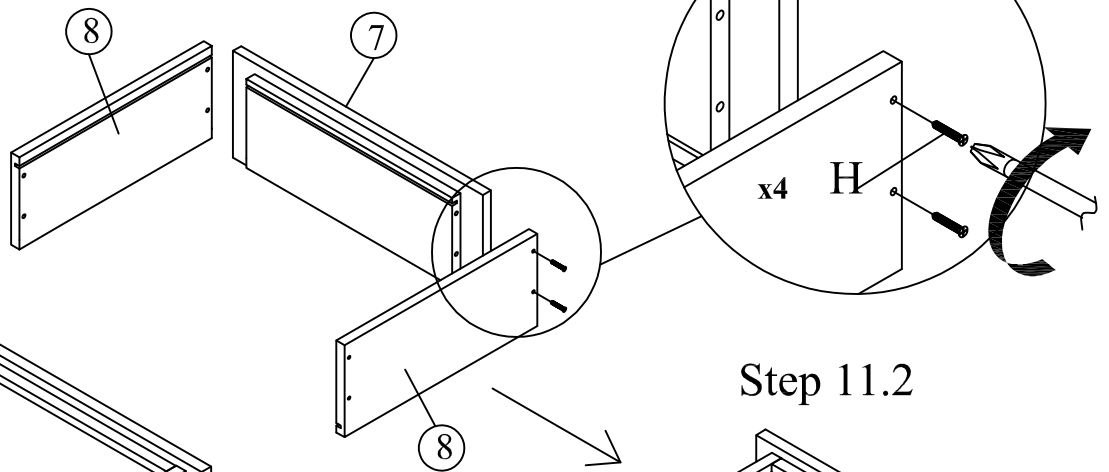

Step 11.3

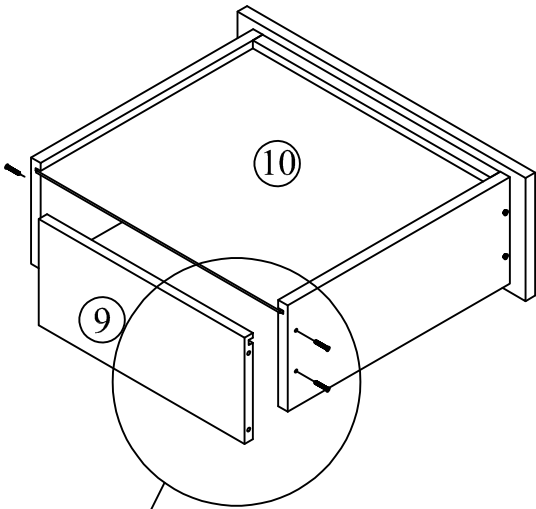

Back View

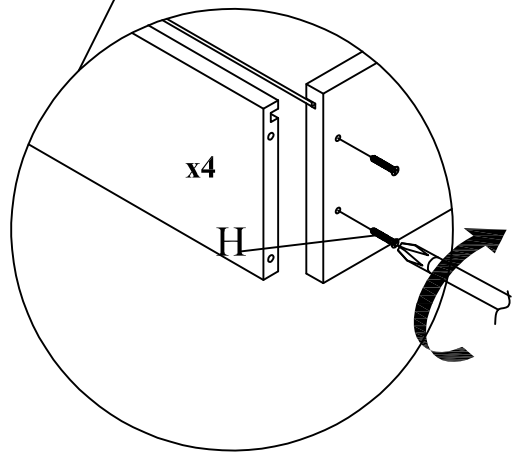

Step 11.2

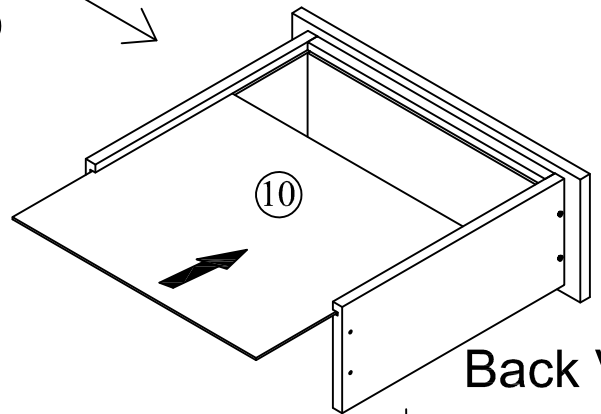

Back View

Back View

Step 11.4

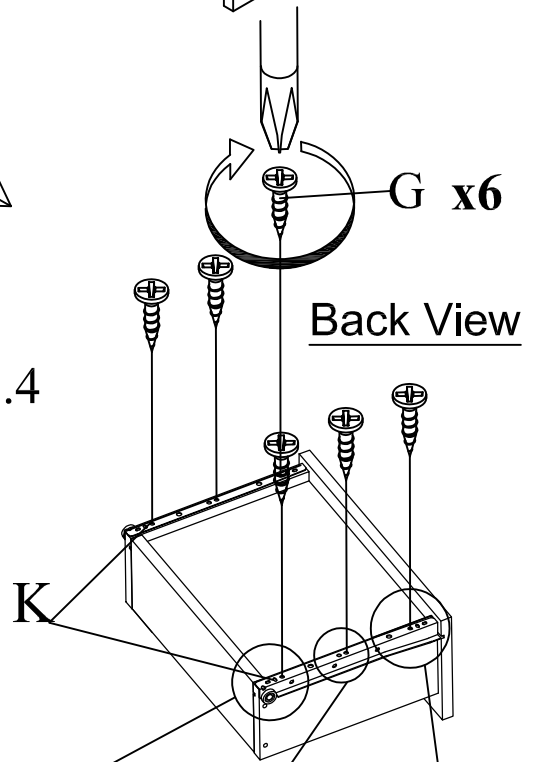

Step 11.5

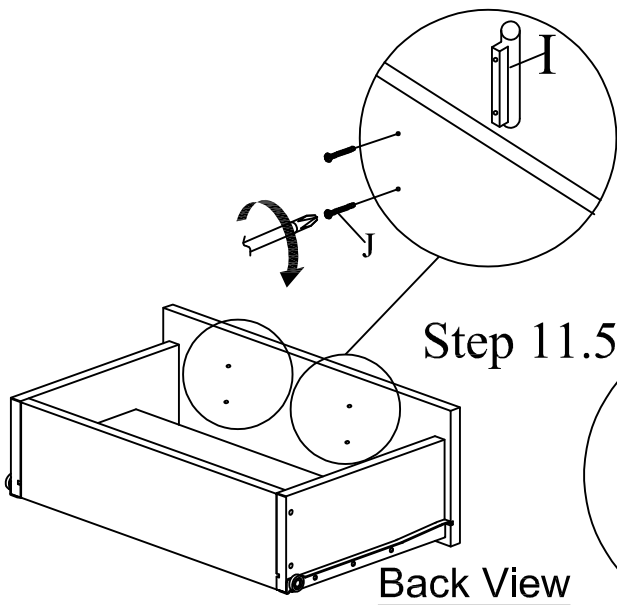

Back View

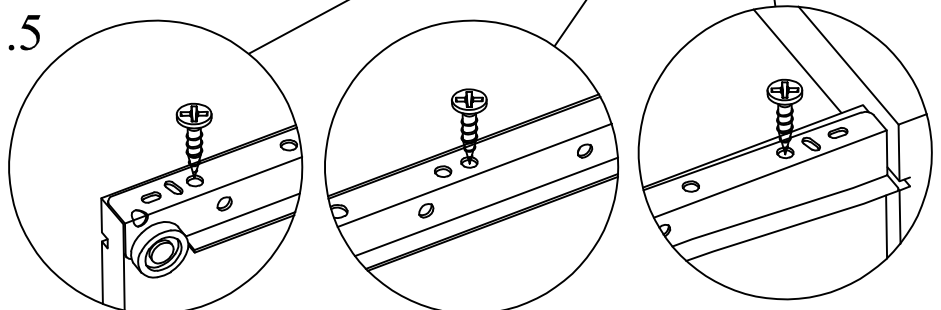

Step 12

