

0089-1 Queen Bed

Assembly Instructions

WI-0622

1 Assembled View

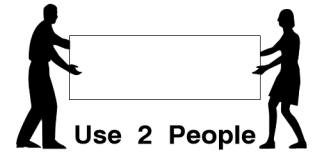
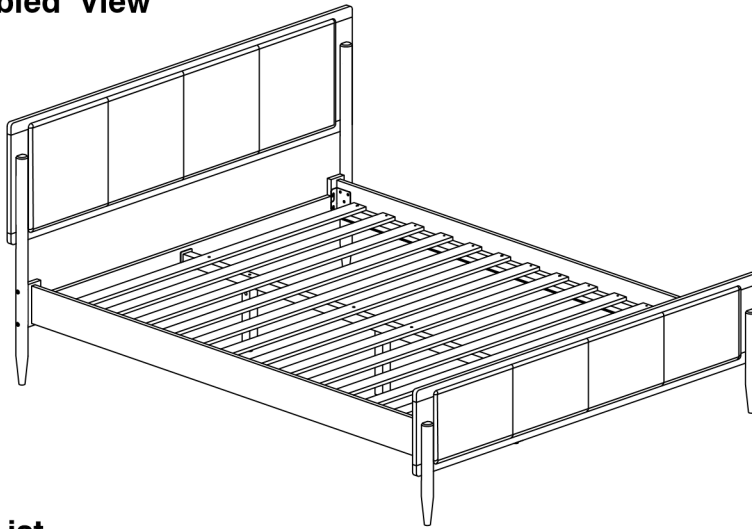

Note: Do not assemble using power tools. This can cause the bolts to be overtightened

2 Parts List

Parts in Box A:

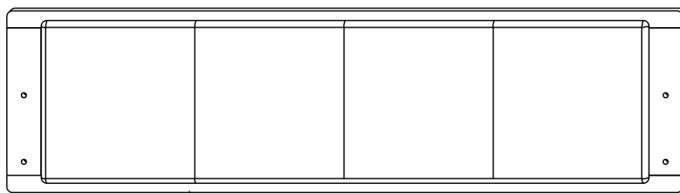

A Headboard x 1

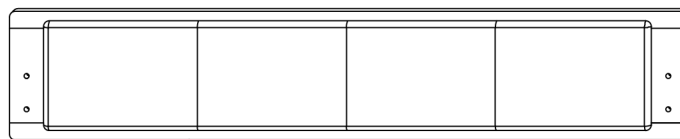

B Footboard x 1

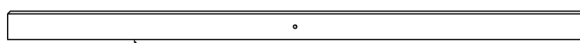

C Headboard Support x 1



D Support Bar (Left Hand) x 1

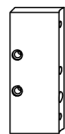

E Support Bar (Right Hand) x 1



F Headboard Post (Left hand) x 1



G Headboard Post (Right hand) x 1

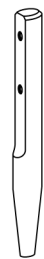

H Footboard Post x 2

Parts in Box B:

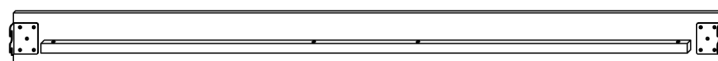

J Side Rail x 2

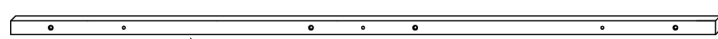

K Long Support x 1



L Support Leg x 3

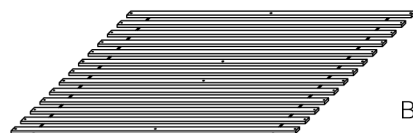

M Set of Bed Slats x 1

0089-1 Queen Bed

Assembly Instructions

WI-0622

3 Hardware List



1 M4 Allen Key
x 1

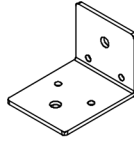

2 Center Rail
Bracket x 2

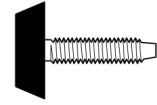

3 Adjustable
Foot x 3



4 Wood Dowel
(M10 x 40mm) x 4



5 Barrel
Nut x 9



6 Wood Screw
(M4 x 32mm) x 18



7 Spring
Washer x 8



8 Flat Washer
x 8



9 M6 x 15mm JCB
x 4



10 M6 x 20mm JCB
x 8

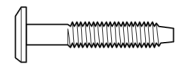

11 M6 x 35mm JCB
x 8



12 M6 x 40mm JCB
x 12



13 M6 x 90mm JCB
x 9

4 Assemble the Support Leg (L) to the Long Support (K).

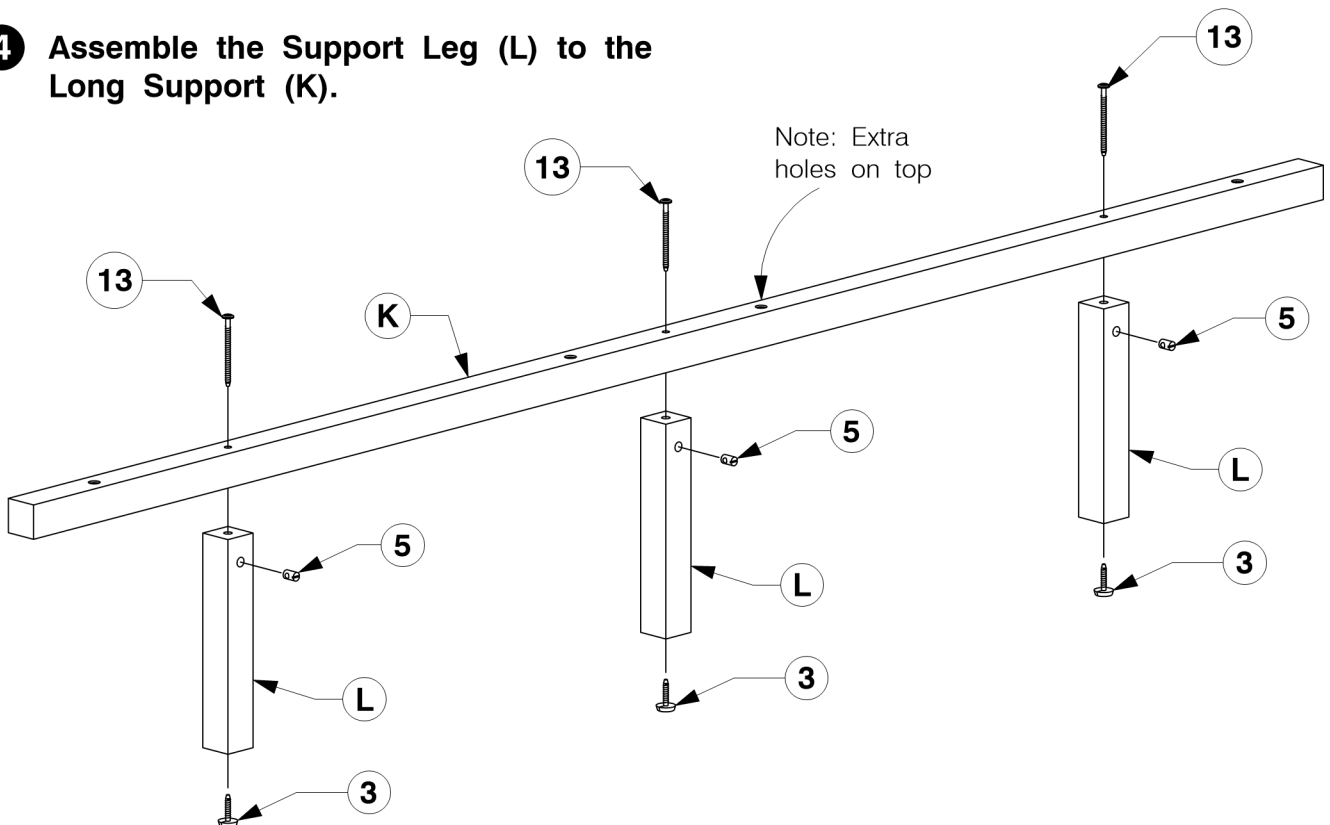

0089-1 Queen Bed

Assembly Instructions

WI-0622

- 5** Fit the Footboard Post (H) to the Footboard (B).

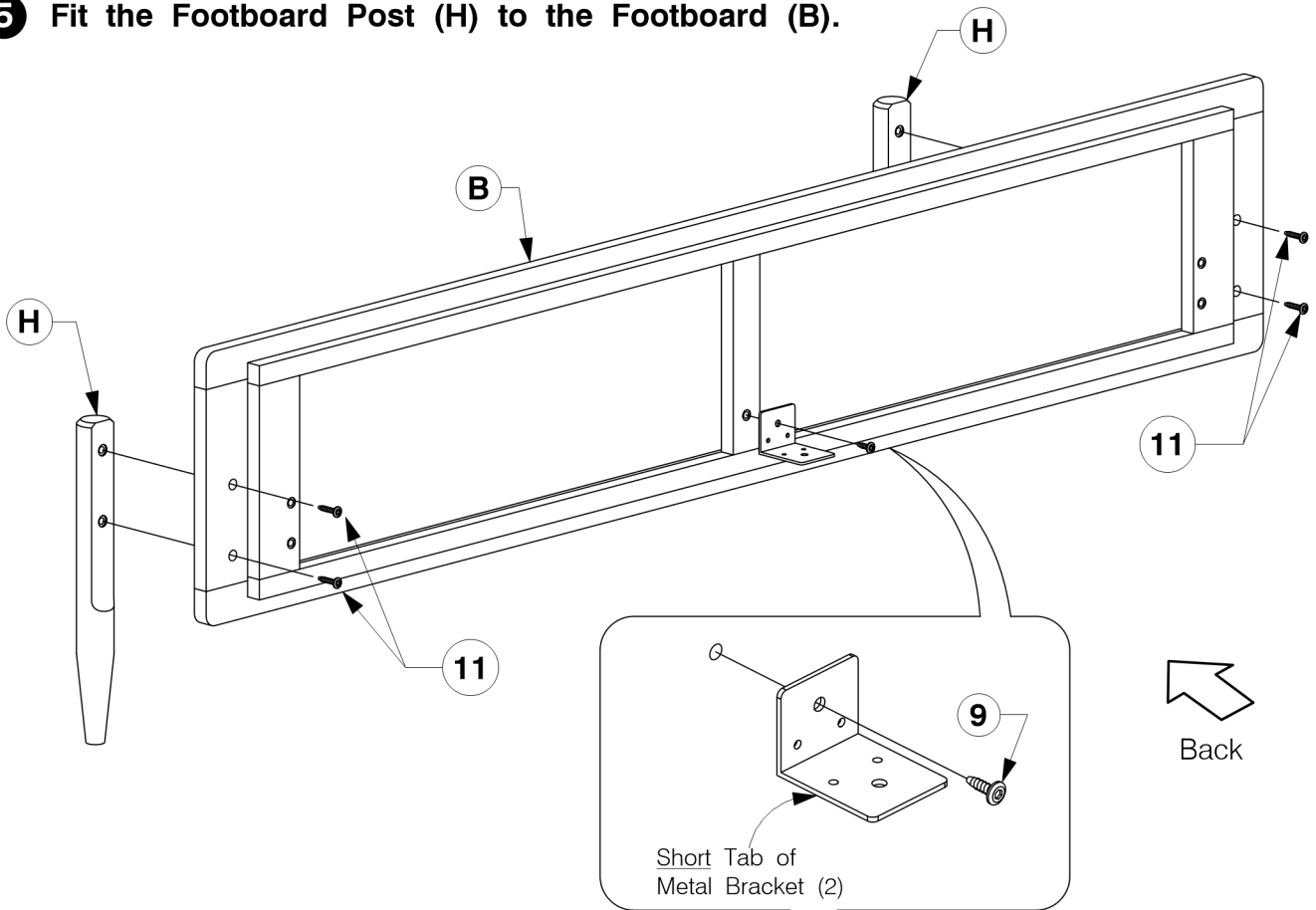

- 6** Fit the Headboard Support (C) to the Support Bar (D & E).

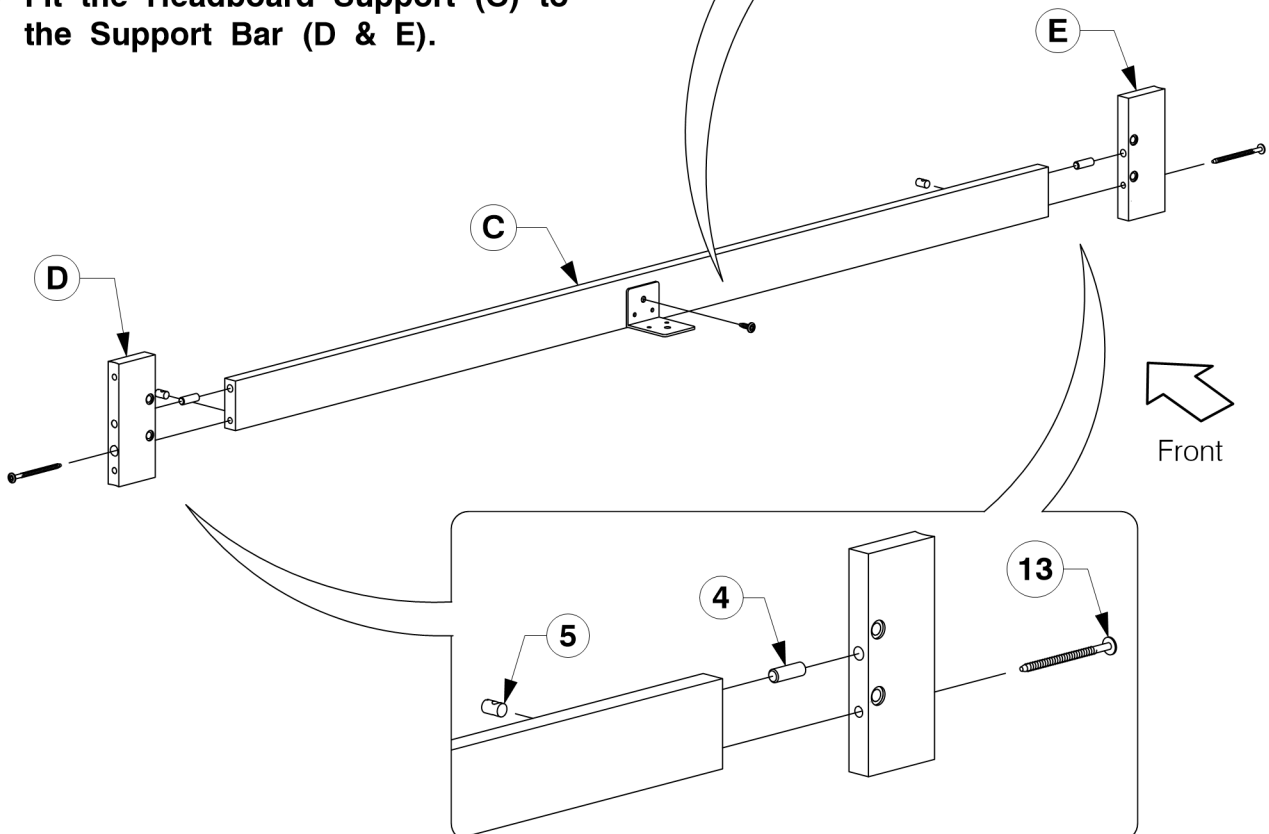

0089-1 Queen Bed

Assembly Instructions

WI-0622

- 7** Assemble the Post (F & G) to the Support Bar (D & E).

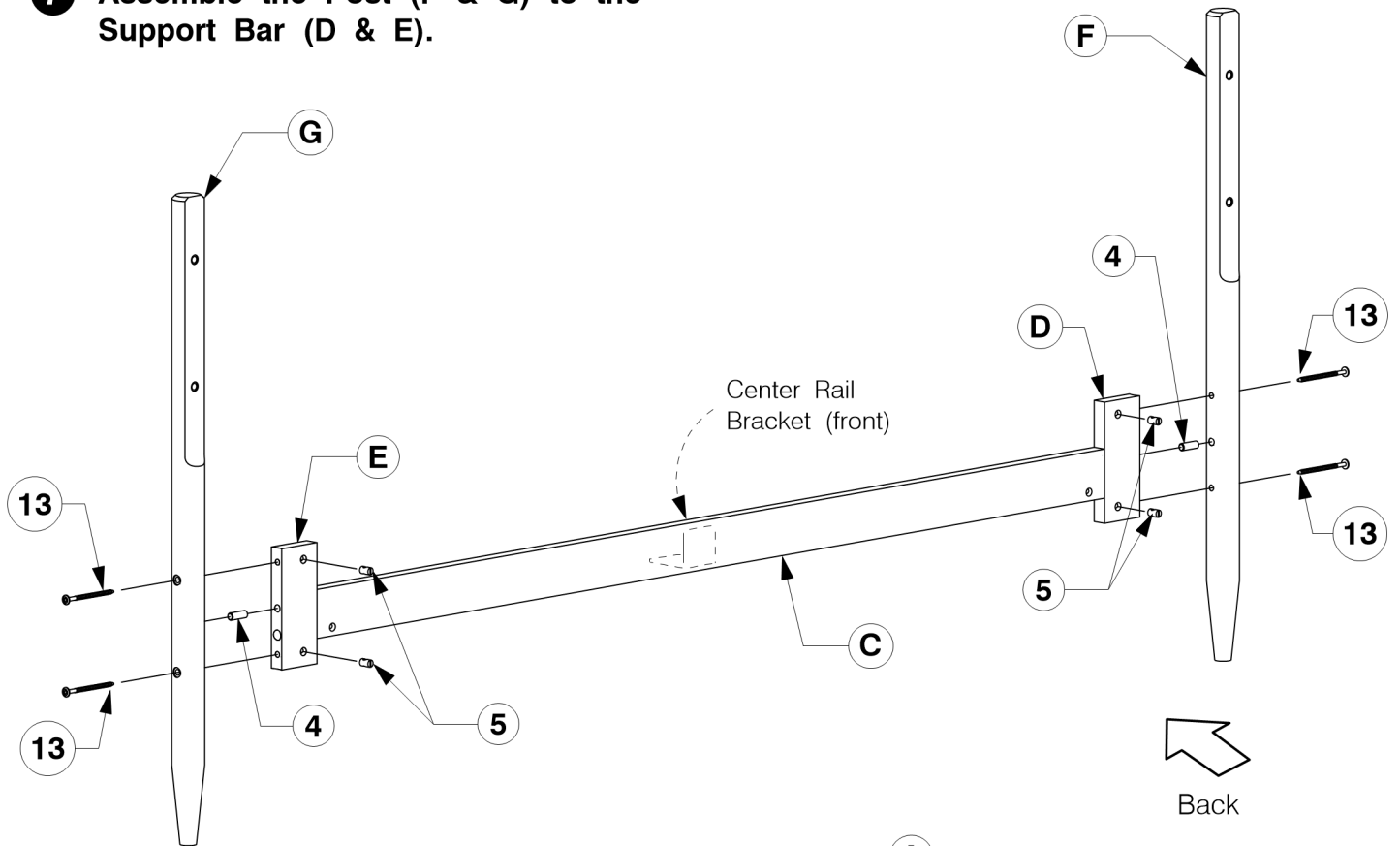

- 8** Fit the Headboard Post (F & G) to the Headboard (A).

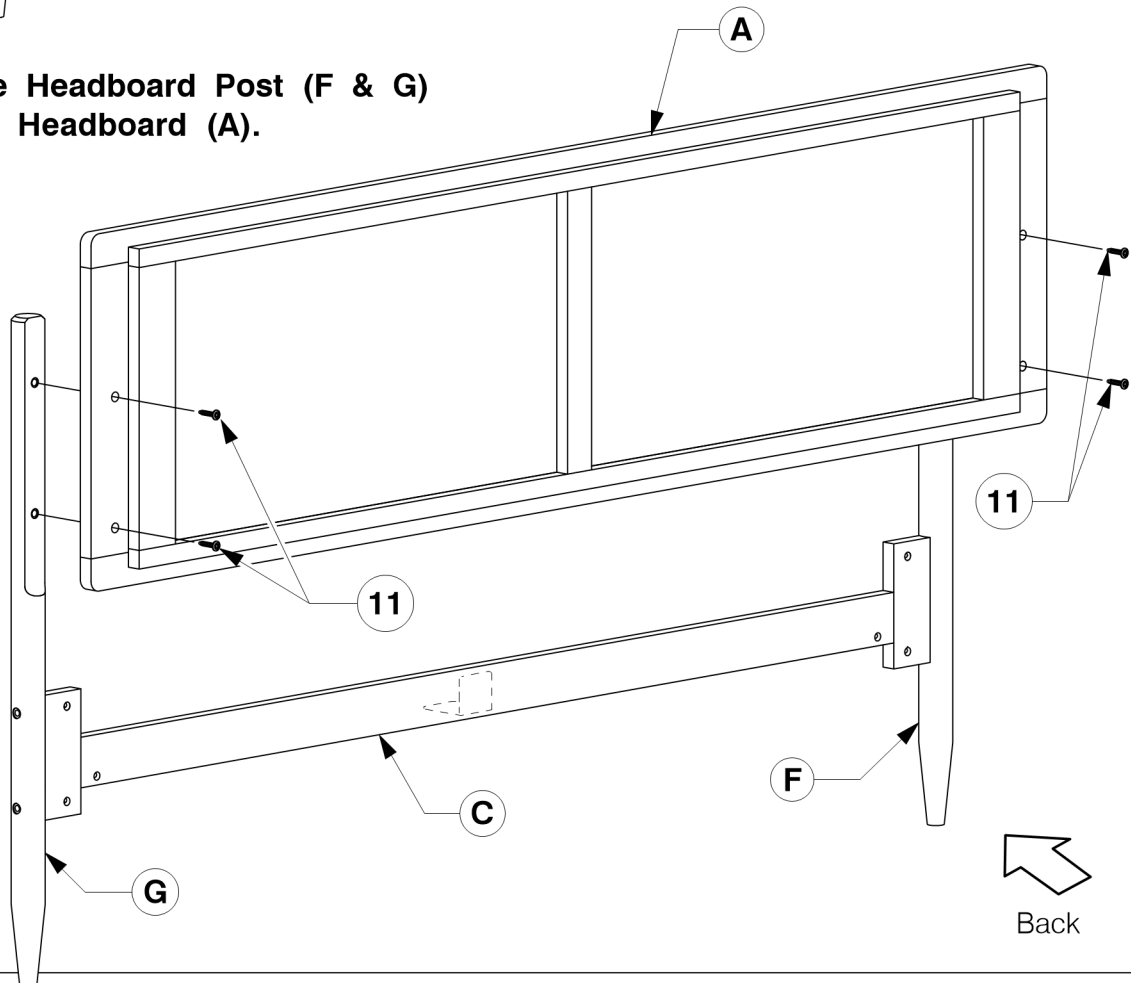

0089-1 Queen Bed

Assembly Instructions

WI-0622

- 9** Fit the Side Rail (J) to the Headboard (A) & Footboard (B).

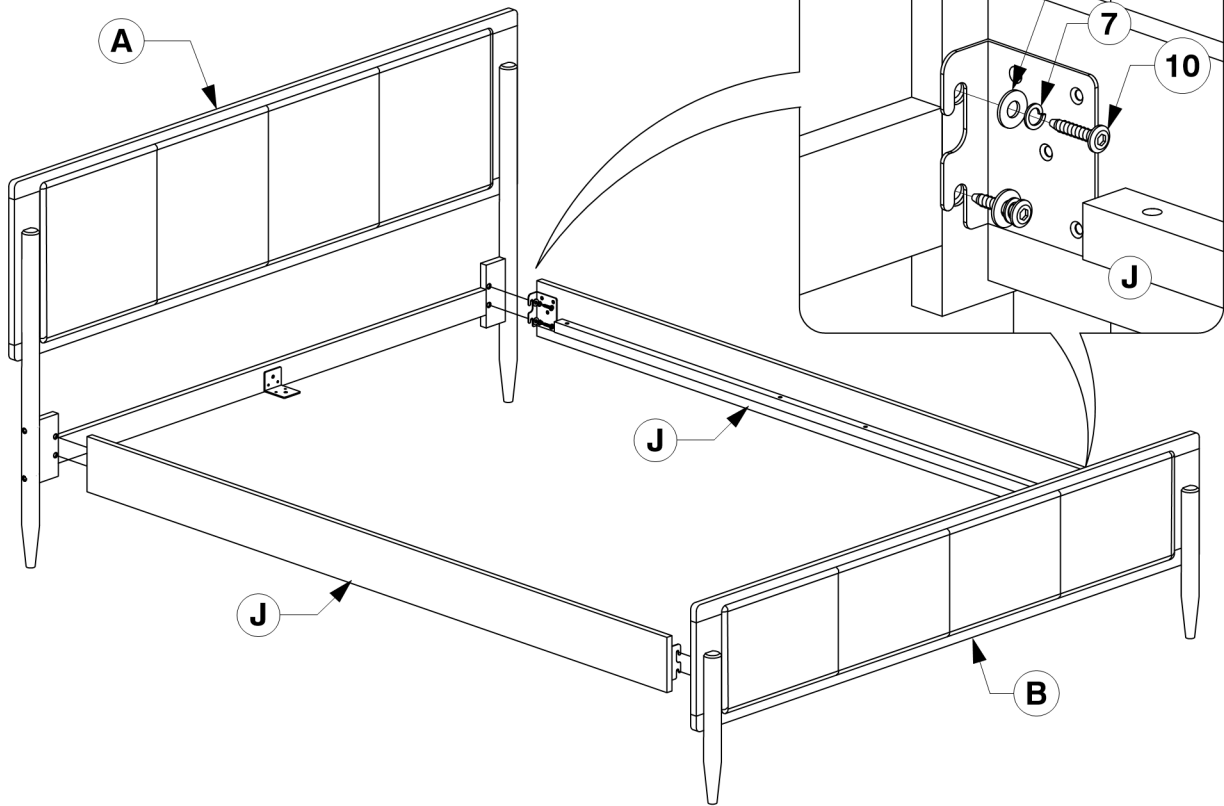

- 10** Bolt the Long Support (K) to the Center Rail Brackets on the Headboard Support (C) and Footboard (B).

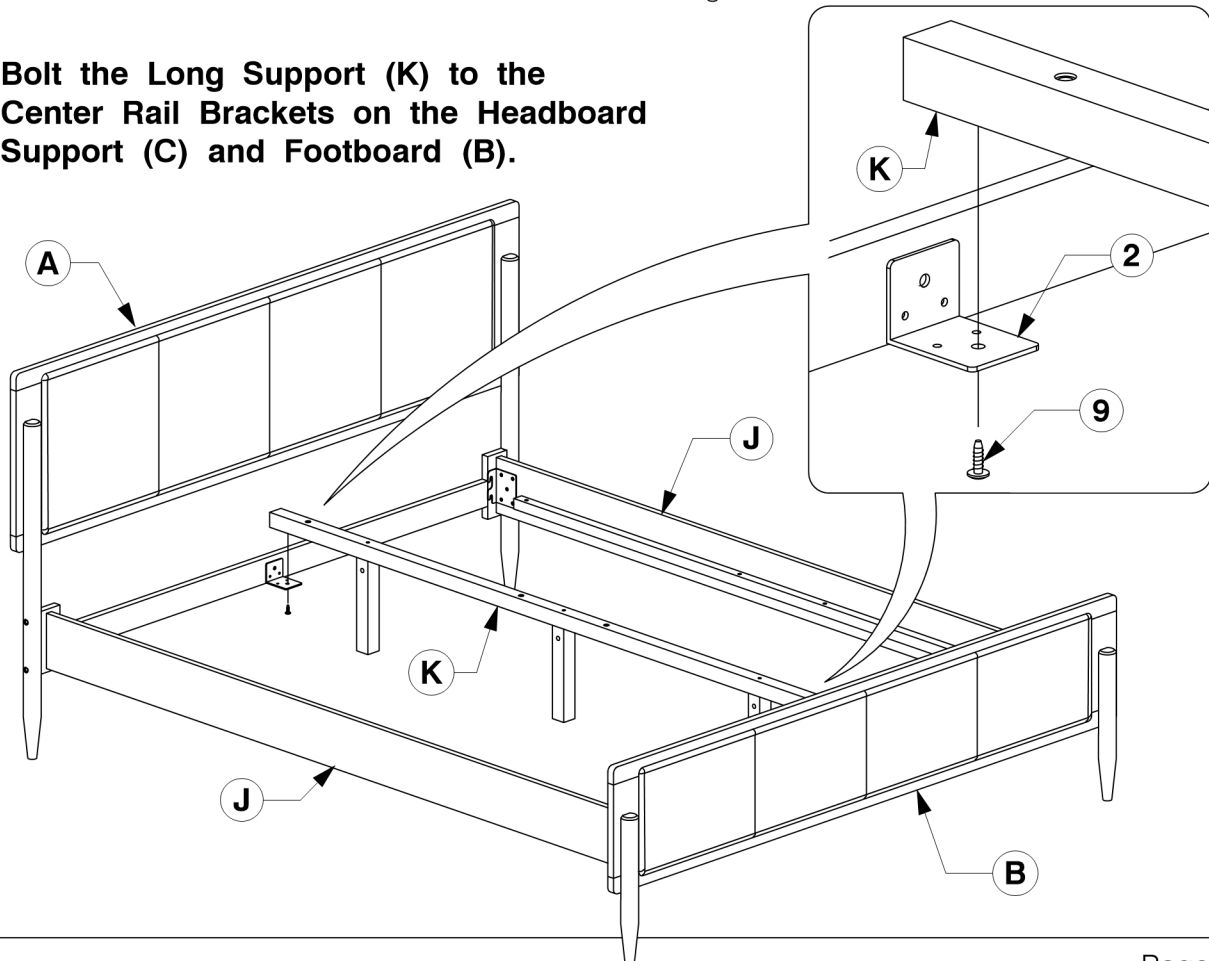

0089-1 Queen Bed

Assembly Instructions

WI-0622

11 Bolt the Bed Slats (M) to the Side Rail (J).

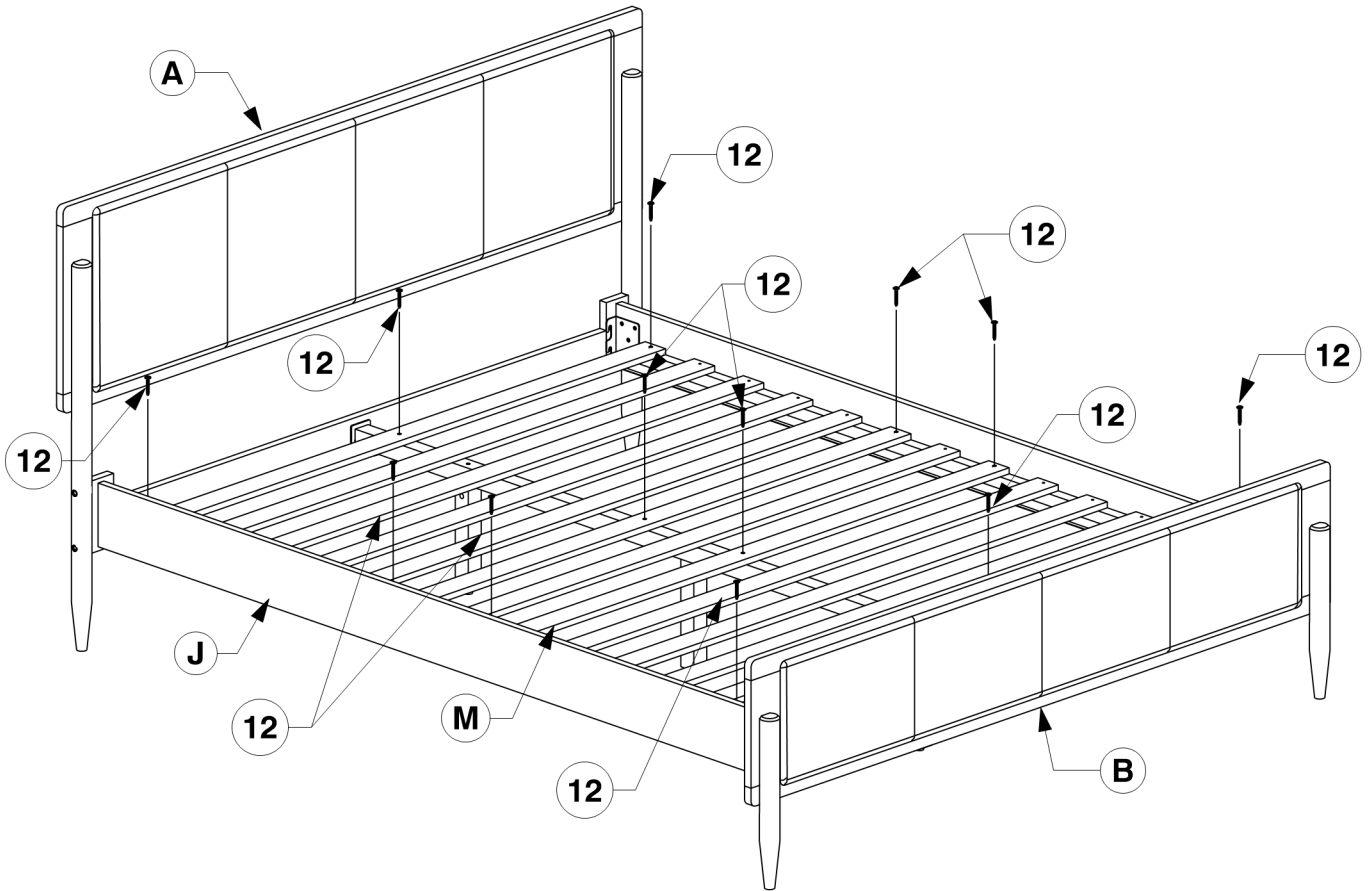

12 Screw the Bed Slats (M) to the Side Rail (J).

